

Diverter Valve

Diverter Valve Designed For Use In Bilge And Toilet Systems

- Robust, reliable design
- Teflon® lubricated non-stick operation
- Precision machined for odour-proof seal
- Withstands sewage, saltwater and bilgewater
- Complies with U.S. Coast Guard rules for Type III waste systems
- Models available in either 25 mm (1") or 38 mm (1 1/2") hose connection

Typical Uses

- Suitable for electric or manual waste management systems
- Used in bilge and toilet waste systems
- Allows one pump to draw from two locations
- Diverts flow to holding tank or overboard
- Diverts flow from holding tank to deck pump out

Model Specifications

Model	Diverter Valve	Diverter Valve
Product Code	DV5630	DV5606
Hose Connections	25 mm (1")	38 mm (1 1/2")
Materials	Main Body: Acetal, Teflon®, Handle: PTFE Polyester	

Strum Boxes

Strum Boxes Ideal For Use In Bilge Systems

- Prevents debris from entering suction hose
- Removable straining plate for easy cleaning
- Top entry and side entry versions available
- Top entry strainer is ideal for deeper bilges, or side entry for more shallow bilges
- Suitable for 25 mm (1") and 38 mm (1 1/2") hose
- Includes a non-return valve to prevent drainback

Model	Top Entry Strainer	Side Entry Strainer
Product Code	SB4222	SB5865
Materials	Polypropylene	

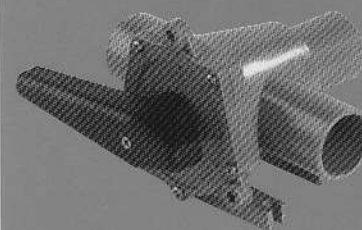
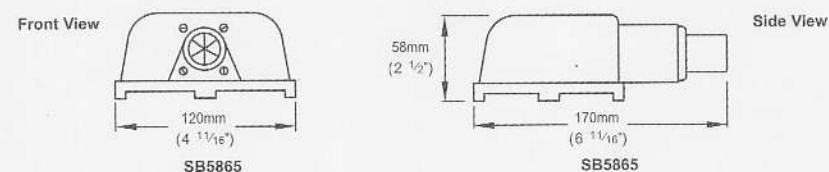
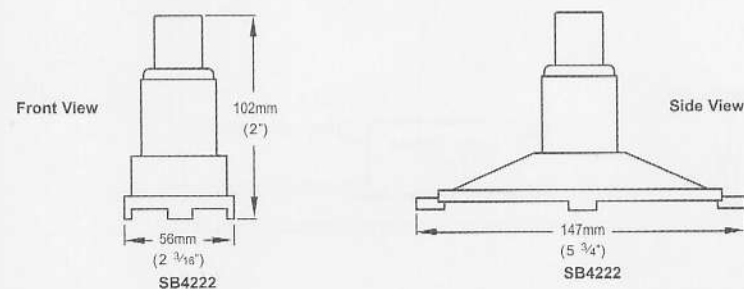

Diverter Valve
5 Year Warranty

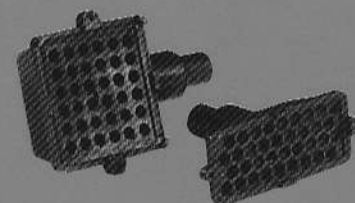
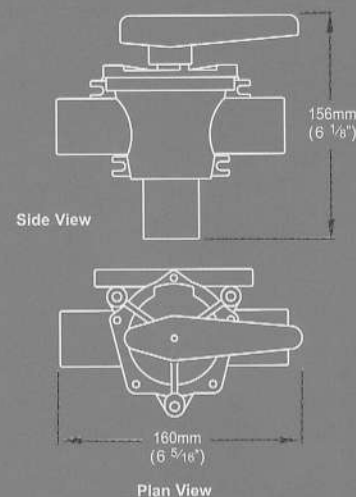

SB5865 SB4222
Strum Boxes
1 Year Warranty