

OWNER'S MANUAL

MARINE KETTLE® CHARCOAL GRILL A10-104 • A10-114



Patent &
Patents Pending



For questions regarding performance, assembly, operation, parts, or returns, contact the experts at MAGMA by calling **(562) 627-0500** 7:00 a.m. - 5:00 p.m. Pacific Time Monday thru Friday or e-mail us at mail@MagmaProducts.com

Made in the
USA 

MAGMA®

U S A

IMPORTANT, read these instructions carefully before use. Familiarize yourself with the appliance before connecting it to its gas container. Keep these instructions for future reference.

IMPORTANT SAFETY WARNINGS

READ ALL INSTRUCTIONS BEFORE OPERATING.

- WARNING! DO NOT USE INDOORS.
- USE OUTDOORS ONLY.
- DO NOT USE THIS APPLIANCE INSIDE THE BOAT OR ANY ENCLOSED SPACE.
- GRILLS RADIATE HEAT. CLEARANCE FROM COMBUSTIBLES, 24" SIDES AND BACK. NEVER USE UNDER AWNINGS, PATIO COVERS, ETC.
- WARNING! THIS GRILL WILL BECOME VERY HOT. DO NOT MOVE DURING USE.
- NEVER LEAVE HOT GRILL UNATTENDED.
- WARNING! DO NOT USE ALCOHOL, GASOLINE OR OTHER SIMILAR LIQUIDS TO LIGHT OR REACTIVATE THE FIRE.
- DO NOT OVERHEAT GRILL, SEE OPERATING INSTRUCTIONS
- WARNING! DO NOT LEAVE THE GRILL WITHIN REACH OF CHILDREN OR PETS.
- USE GLOVE OR HOT PAD WHEN HANDLING HOT GRILL.
- DO NOT BLOCK, RESTRICT, OR OTHERWISE OBSTRUCT COMBUSTION OR VENTILATION AIR OPENINGS.
- DO NOT MODIFY THIS APPLIANCE.

CONTENTS

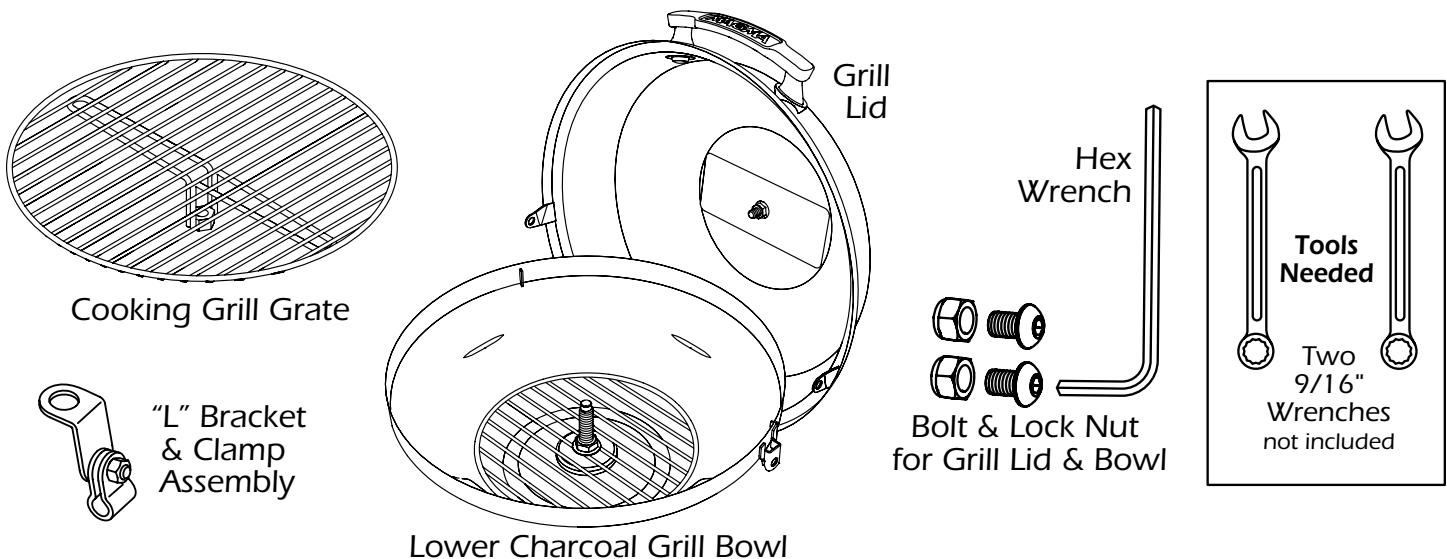

ATTACH THE LID TO THE BOWL

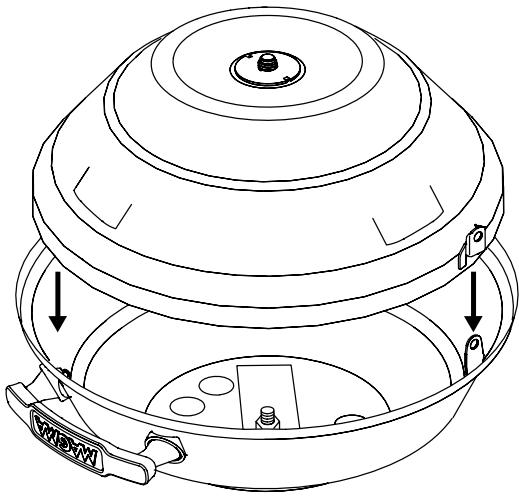

1

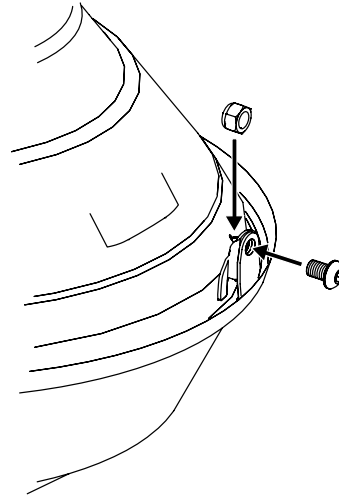

2

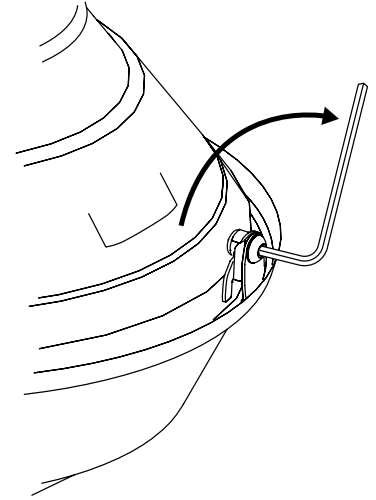

3

GRATE ASSEMBLY

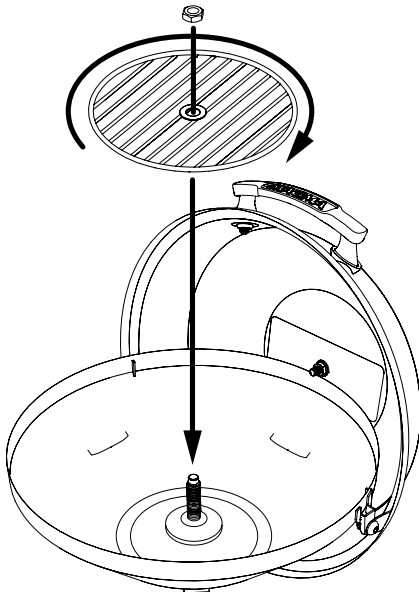

1

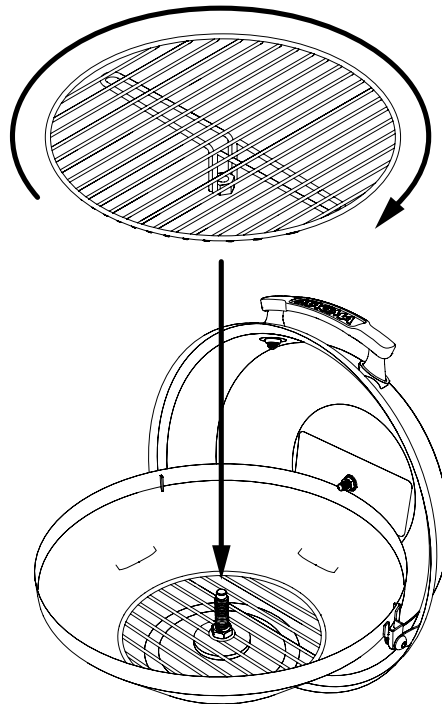

2

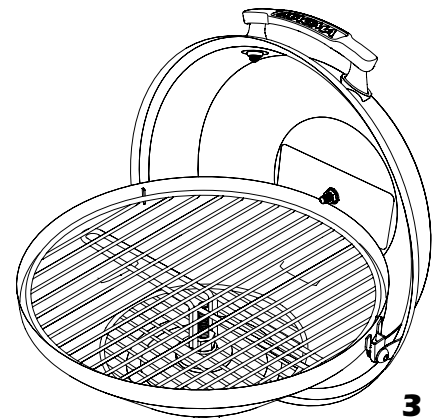

3

3

"L" BRACKET & CLAMP ASSEMBLY

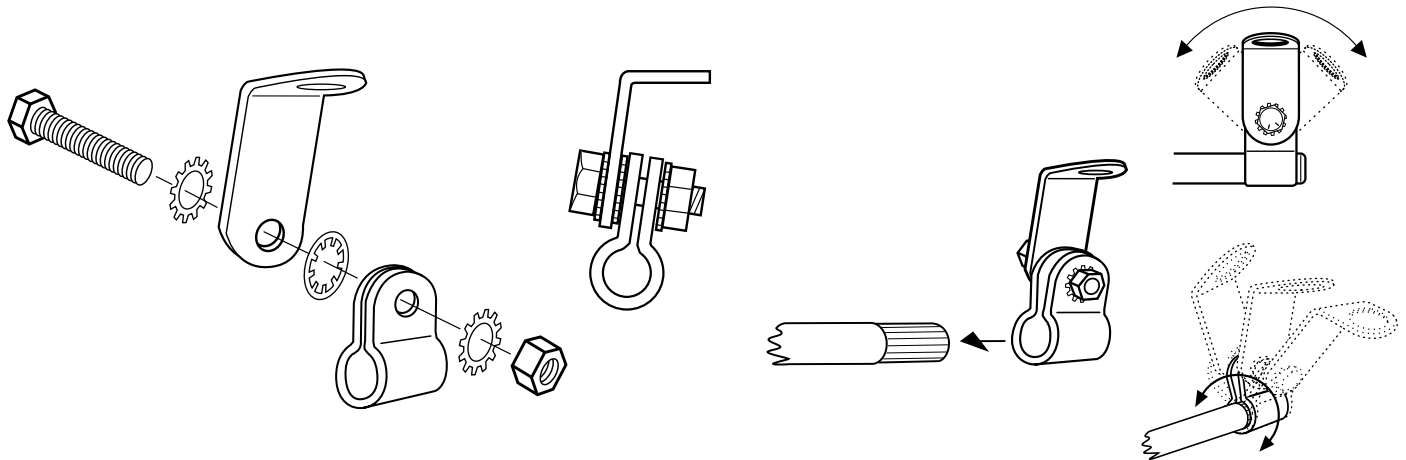

SETTING UP YOUR GRILL

Mounts sold separately.
Visit our website MagmaProducts.com for mounting options.

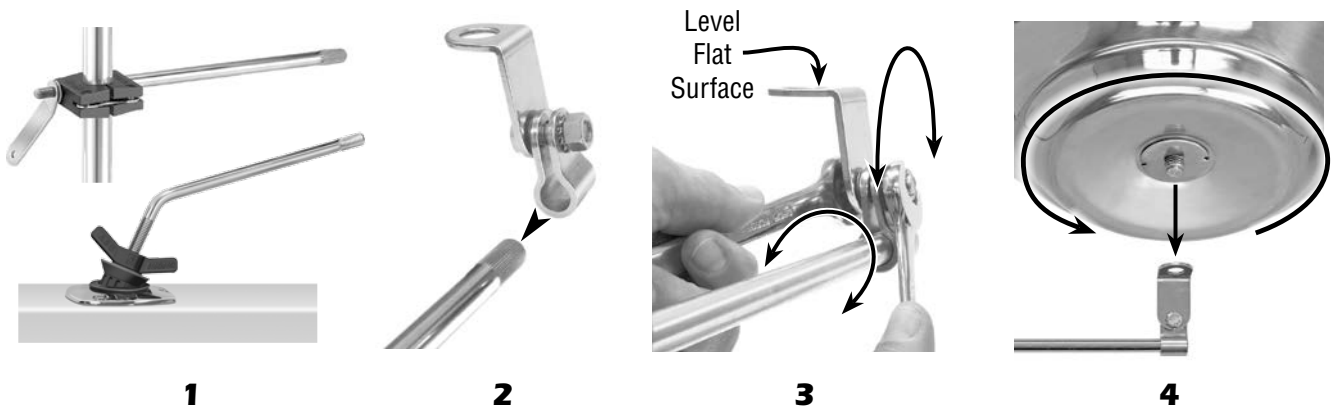

1. Select and install appropriate Magma mount in your desired location. Prior to installing the grill, check that mount does not easily move with a reasonable force applied.
2. Slide L-Bracket & Clamp on to mount knurled rod.
3. Adjust threaded flat surface of L-Bracket to level position and tighten firmly with two 9/16" or adjustable wrenches so L-Bracket & Clamp cannot be moved.
NOTE: Level positioning is critical for even temperatures across grills cooking surface.
4. Carefully hold grill body, with lid closed, and thread on to L-Bracket **TIGHTLY** so that grill does not unthread easily. Check grill is tight and level prior to proceeding.

ADJUSTING GRILL TO WINDY CONDITIONS

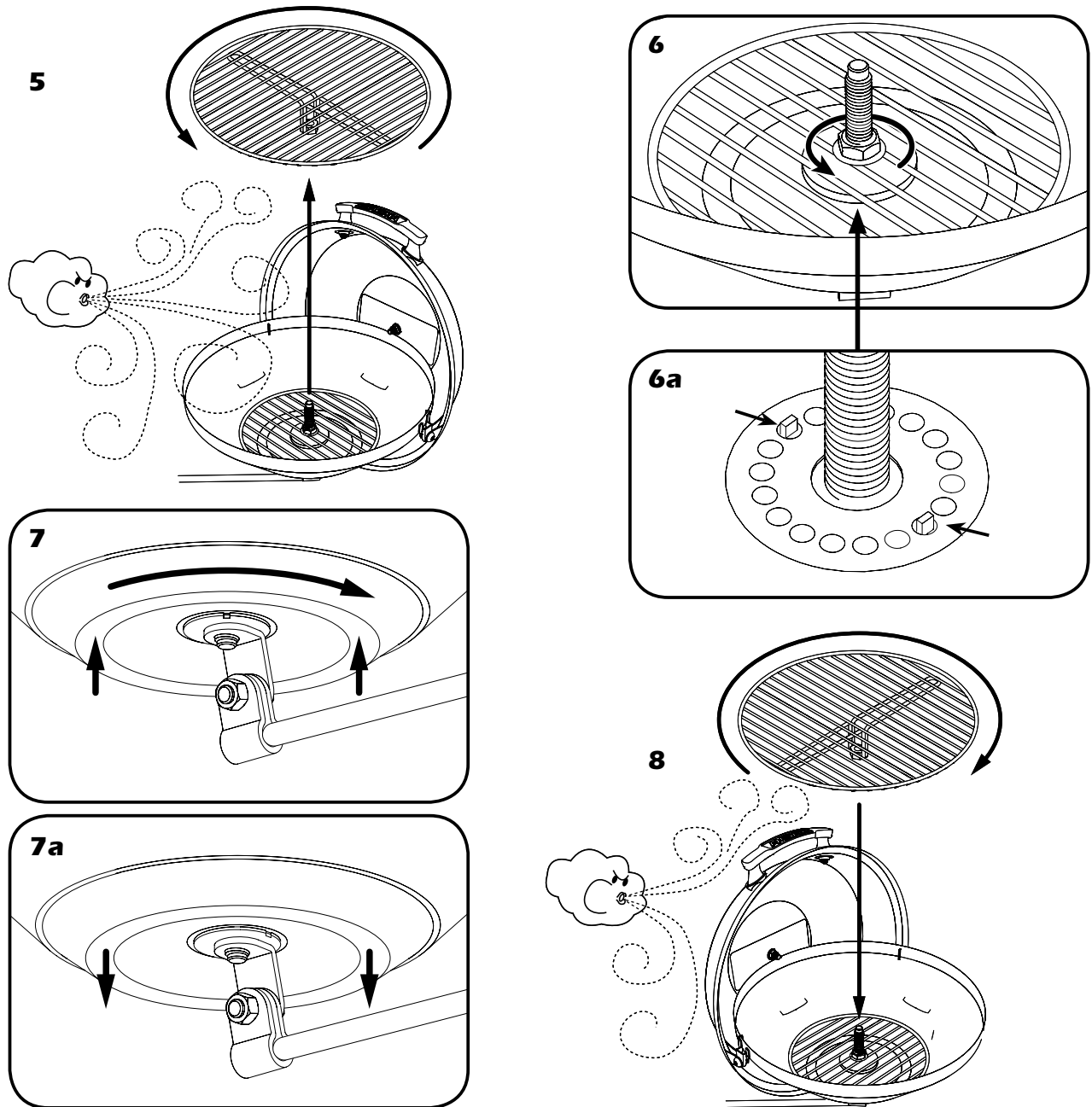

- 6.** Remove cooking grill grate
- 7.** With grill body tightly attached to L-Bracket, unthread lower charcoal grill nut **3 full revolutions.** **(6a)** Lift entire grill up to disengage from stud positioning pins.
- 8.** Rotate so lid operates freely in the desired position. **(7a)** Carefully lower back down, making sure pins are re-engaged and rethread the "nut" 3 revolutions until tight. If the nut does not turn 3 revolutions the pins are not engaged properly.
- 9.** Reinstall cooking grill grate over threaded center post — turn clockwise until at desired height.

OPERATING PROCEDURES

GETTING READY TO COOK

- Position grill lid to block the wind. (See page 5).
- Remove cooking grill **A**, by unscrewing it from threaded center post.
- Fill Magma "Charcoal Starter" (#A10-150) with briquets, or stack two handfuls away from the center post, then soak the briquets with lighter fluid per can instructions.
- Wait one minute before igniting. Then, preferably, use a long nozzle butane lighter to light the briquets.
- When briquets are ready, spread the hot briquets evenly across the lower grill.
- Replace the upper cooking grill by threading it to the desired height.
- Now you're ready to cook on your Magma grill!

NOTE: The Magma "Charcoal Starter" helps extend grill life, helps keep threaded center post clean, and makes handling of coals safe and simple.

WARNING: Do not overheat the grill. Stainless steel is a strong and long lasting material, but like any metal, extreme heat can cause damage and discoloration.

SAFETY

- Use outdoors in ventilated area, clearance from combustibles 24" (61 cm).
- When operating grill, never leave unattended.
- Use glove or hot pad when handling hot grill.
- Always keep a fresh water spray bottle handy to reduce heat and flare-ups.
- CAUTION: Excessive flare-ups will continue if the grill is too hot. To cool grill, spray fresh water on flare-ups until cool.
- When using lighter fluid read instructions and safety precautions on lighter fluid container.

STOWING

- After grill is cool, remove grill from mount and stow. See **④** (page 4) Do not loosen or detach "1/8" to stow. See **②** (page 4).
- Remove the cooking grill from the threaded center post when not in use and for long term storage.

MAINTENANCE

- Clean grill regularly for best performance.
- Clean and lubricate the threaded center post between uses.
- Clean all metal parts with oven cleaner per oven cleaner instructions. CAUTION: Do not use steel wool or abrasive cleaners.
- Clean all other parts with mild detergent and water.

COOKING TIPS

- Always cook with lid on.
- Timing is very important. Make sure food is prepared before lighting the grill so cooking is completed while the briquets are still hot.
- The grill becomes hotter while cooking. Frequent checks should be made during cooking until familiar with grill.
- To reduce flare-ups, use lean cuts of meat, trim excessive fat or skin, and avoid oil based marinades.
- If flare-ups occur, reduce heat with fresh water spray bottle, and move food away from flare-up.
- For larger cuts of meat or delicate items, use aluminum foil between food and grill to deflect direct heat.
- Lubricate cooking grill with olive oil to keep food from sticking.

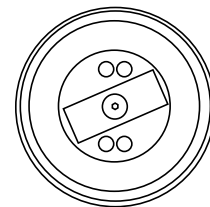
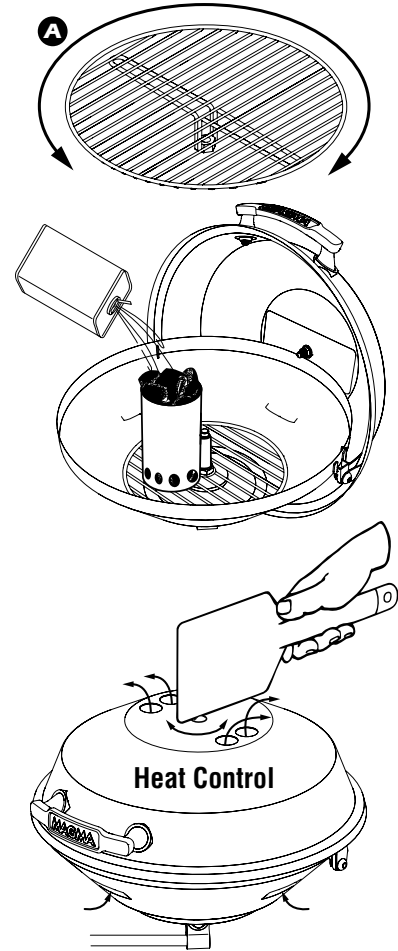

High Temperature

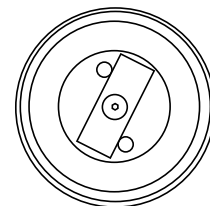

Medium Temperature

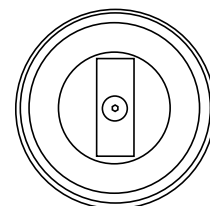

Off

MAINTENANCE

Stainless steel contrary to popular belief can rust. Most commonly, deposits on surface of the product will trap moisture. It is this moisture that robs stainless steel of oxygen. Oxygen is the element that reacts with stainless steel to form a protective layer of chrome oxide. Robbed of oxygen, this reaction does not take place and “crevice corrosion” or “surface rusting” occurs. To minimize this effect, thoroughly clean your grill with soap and water, rinse with fresh water, and dry. Avoid using stainless steel polishes on grill exterior as most leave a residue that may discolor when grill is heated.

Additionally, stainless steel that is exposed to high heat will change color and texture over time. The “amber” color of grill exterior and internal components is not a failure of the stainless steel and will not affect products operation. When this happens, we recommend using **“Magma Magic” Grill Restorer** to remove the “amber” color and return grill to its original luster. However, prolonged exposure to extreme high heat will cause chromium and nickel to “burn out” of stainless steel. At this point stainless steel will become more susceptible to corrosion and will start to deteriorate. We recommend replacement of internal components as they become seriously deteriorated.

We recommend thoroughly cleaning grill and internal components after each outing. Disassemble interior components and remove all food residue. Use a “Scotch-Brite” pad or similar product and “Easy-Off” oven cleaner for cleaning grills interior components, followed by thoroughly washing with soap and water, rinse with fresh water & dry. **AVOID CONTACT OF OVEN CLEANER WITH SKIN, AND BOAT SURFACE. CAUTION: DO NOT USE ANY TYPE OF ABRASIVE PAD ON EXTERIOR MIRROR FINISH AS IT WILL SCRATCH SURFACE, USE ONLY A SOFT CLOTH.** We recommend covering grill between uses. Grill covers are available at Magma retailers or directly from Magma. See our website, **MagmaProducts.com**.

Grill Grates

Clean with brass wire brush while grill is warm. Use Oven & Grill cleaner for burnt-on residue. Wash with soapy water and dry prior to storage.

Repair/Replacement Parts

All replacement parts are readily available at your Magma Retailers or directly from Magma. For a complete list of replacement parts, see page 8, or visit our website **MagmaProducts.com**.

REPLACEMENT PARTS

A10-104
"Original" Size

A10-114
"Party" Size

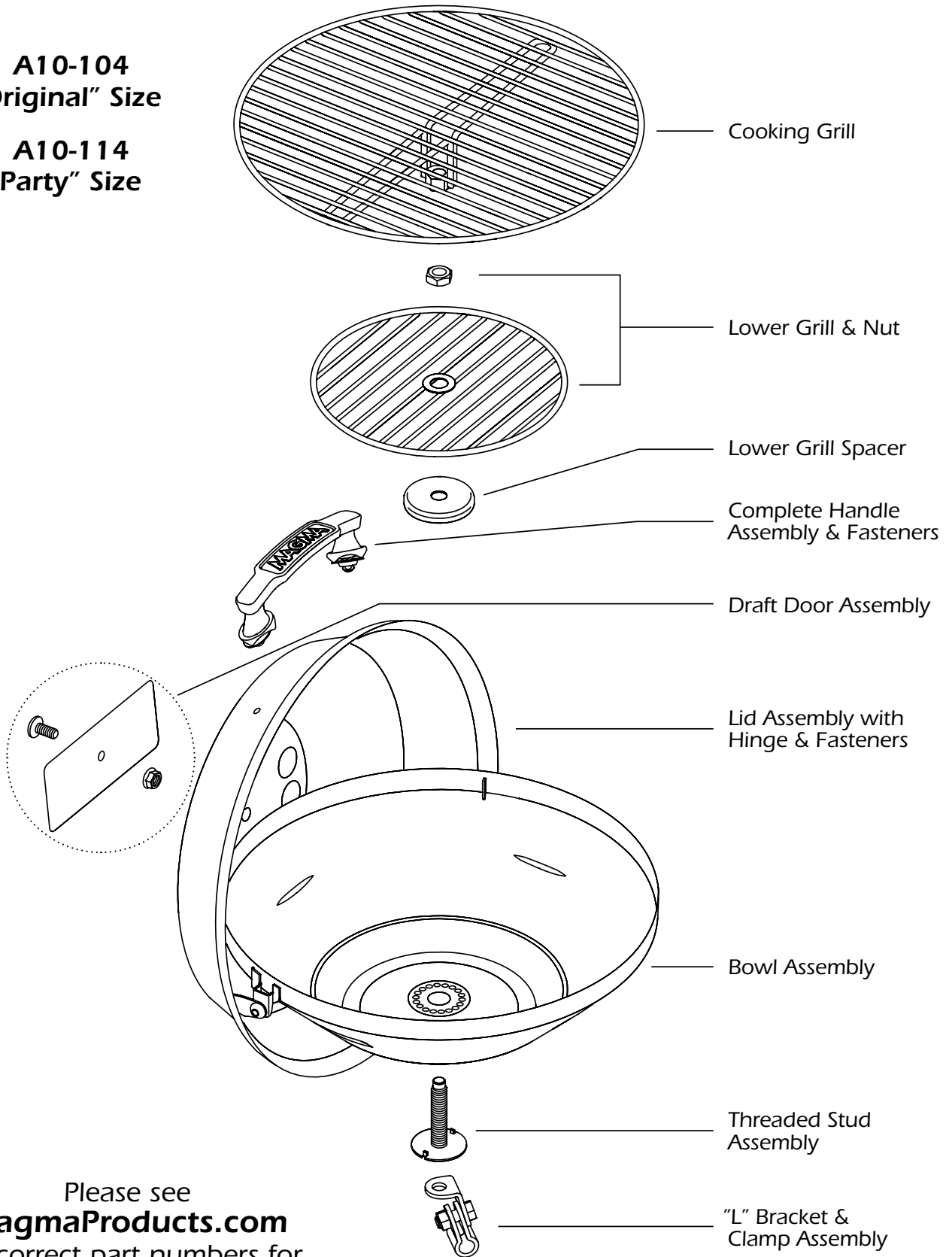

Please see
MagmaProducts.com
for correct part numbers for
the Replacement Parts above

ACCESSORIES



sunbrella™

Magma® Marine Kettle® Grill Cover/Tote Bag
Original & Party Size



Fully "Nesting," 7 & 10 piece, 18-10 Stainless Steel Cookware Sets with Stainless Steel or Ceramica Non-Stick Interiors.
Stainless Steel, Cobalt Blue, Jet Black, or Magma Red enamel exteriors and Induction compatible models available.



Stores in less than 1/2 cubic foot



Luggage Quality Padded Grill & Accessory Carry/Storage Case
Fits grills up to 17" dia. (43 cm)



LED Grill Light
High-intensity LED light for grilling after dark



"Telescoping" Grill Tools & Storage/Carrying Case
Grill Tool Set, 5 Piece
Individual tools also available



LED Grill Tool Light
High-intensity LED light easily attaches to any Magma Telescoping Grill Tool.



Fish & Veggie Grill Tray
18-9 Stainless Steel or 18-9 Stainless Steel with Non-Stick



Reversible "Non-Stick" Griddle
Heavy duty marine grade cast aluminum with Non-Stick Coating



Gourmet Grilling Apron
100% cotton, adjustable with embroidered Magma logo, 2 pockets, and towel loop
Jet Black or Magma Red



Grill Mitt
100% quilted heat resistant cotton construction with embroidered Magma logo & silicone palm and thumb • *Jet Black*



Grilling Towels
100% cotton with grommet, embroidered Magma logo (2-Pack) 16-1/2" x 21"
Jet Black



"Flat" Kabob Skewers
25 skewers per pack
100% Hygienic Bamboo
Food won't roll when turned



Gourmet Meat Thermometer
304 Marine Grade Stainless Steel
2" Face



Gourmet Steak-O-Meters
4-Pack - 304 Marine Grade Stainless Steel
1" Face



"Marine Cuisine"® Grill Guide & Cookbook
130 pages of recipes & tips for portable grilling



Magma Magic Grill Restorer
Removes amber color from all Magma Grills • *USA only*

See Our Website MagmaProducts.com for a Complete List of Accessories

MOUNTS



Round Rail Mount



Side (Bulkhead) or Square/Flat Rail Mount



POW'R GRIP™ Fish Rod Holder Mount



Socket Type Rod Holder Mount
Fits Tempress Fish-On® & Roberts Rod Holder Sockets



Surface Deck Socket Mount

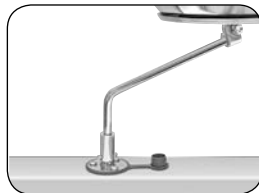

Flush Deck Socket Mount



Double Locking "Stowable" Pedestal Mount 28" (71 cm)

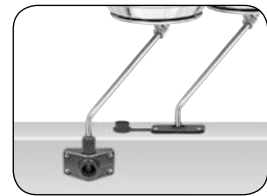

Socket Type Rod Holder Mount
Fits Scotty®/Striker Grip Rod Holder Sockets



Shore Stand/ Table Top Legs

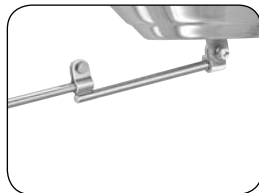

Mounting Extension

LIMITED WARRANTY

Magma Products, Inc. guarantees this product to be free from defects in materials or workmanship to the original consumer. This guarantee is for the periods herein specified when used under normal and reasonable conditions, one (1) year from the date of original purchase. This warranty does not include the cost of property damage or any inconvenience due to the failure of the product. Nor does it cover damage due to misuse, abuse, accident, or damage resulting from transportation of the product. Nor does it include damage resulting from the commercial use of this product. Nor does it include, on stainless steel products, "Surface Rust"; Excessive Corrosion due to exposure to salt water; or Discoloration or Corrosion caused by exposure to excessive heat or failure to properly clean and care for the stainless steel surfaces. If the product fails to operate due to a defect in materials or workmanship during the warranty period, the defective part will be repaired or replaced at Magma's option. If you wish to obtain performance under this limited warranty, you should contact Magma's Customer Service Department via telephone at (562) 627-0500, or via e-mail at mail@MagmaProducts.com, or via U.S. Postal Service mail at "Magma Products, Inc., Attention Customer Service, 3940 Pixie Ave. Lakewood, CA, 90712". The defective part, along with proof of purchase, must be returned postage prepaid to Magma Products, Inc. We suggest that you keep your purchase receipt as we may require reasonable proof of purchase.

In the state of California only, if refinishing or replacement of the product is not commercially practicable, the retailer selling the product, or Magma Products, Inc., will refund the purchase price paid for the product, less the amount directly attributable to use by the original consumer prior to the discovery of the nonconformity. In addition, in the state of California only, you may take the product to the retail establishment from which it was purchased or to any retail establishment selling this product in order to obtain performance under this warranty. All implied warranties, including the implied warranties of merchantability and fitness for a particular purpose, are limited in duration to the express warranty periods specified herein for the parts described herein. Some states do not allow limitations on how long an implied warranty lasts, so the above limitation may not apply to you. Neither Magma dealers, nor the retail establishment selling this product has any authority to make any warranties or to promise remedies in addition to or inconsistent with those stated above. Magma's maximum liability shall not exceed the purchase price of the product paid by the original consumer. Some states do not allow the exclusion or limitation of incidental or consequential damages, so the above limitation or exclusions may not apply to you. The warranty gives you specific legal rights and you may also have other rights which vary from state to state.

MAGMA and the Magma logo are registered trademarks of Magma Products, Inc. Patent pending.

MAGMA[®]

U S A

Magma Products, Inc.
3940 Pixie Avenue, Lakewood, CA 90712 • USA
Phone (562) 627-0500 • mail@MagmaProducts.com
MagmaProducts.com