



Mounting and Operating Instructions for Outboard Motor Bracket Models 71033, 71056, and 71039

Form 12.185

IMPORTANT INSTRUCTIONS

Transom Mounting Hardware **NOT** Supplied Due to Various Transom Thicknesses.

Recommend 5/16" Stainless Steel Fasteners

1. Read instructions completely before starting assembly.
2. Motor bracket must remain in "UP" position throughout installation.
3. **DO NOT** operate motor bracket unless motor is installed on bracket.
4. **NOTE:** This bracket is under spring tension. Exercise extreme caution when adjusting and installing.

BRACKET ANGLE ADJUSTMENT INSTRUCTIONS

Refer to Fig. 1.

Measure the exact angle and direction of the transom on your boat. Determine if your motor can be adjusted so the cavitation plate is parallel to the waterline. If this is possible then skip the following adjustment instructions (Figs. 2-7) and go to the "Mounting Instructions" on Page 3. If your motor cannot be trimmed properly, then follow the section below for the type of transom you have: "POSITIVE" or "NEGATIVE."

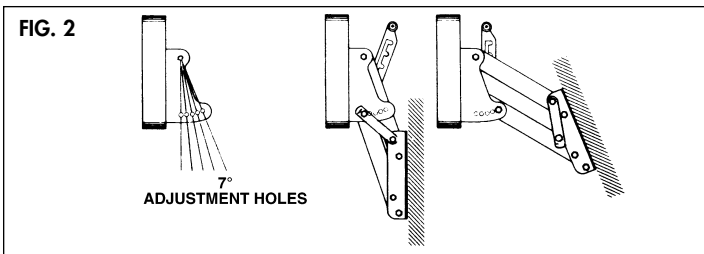
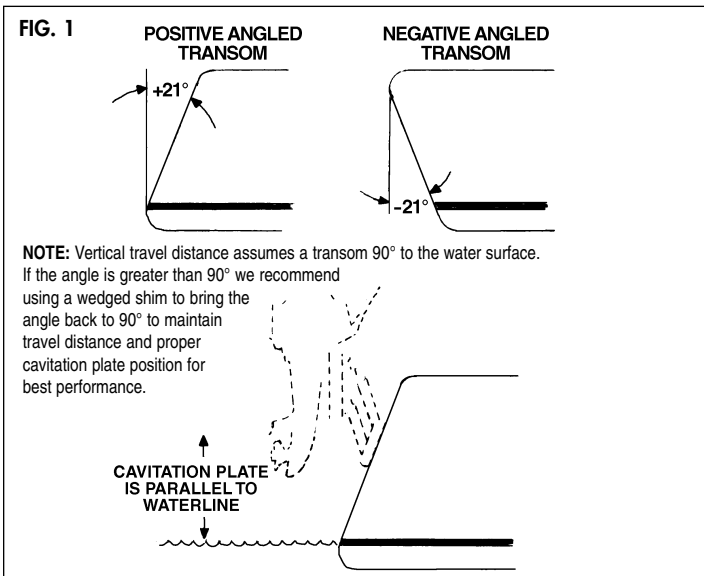

FOR NEGATIVE ANGLED TRANSOMS

Refer to Fig. 2, 3 & 4

Now that the angle and direction of your transom have been determined, choose the adjustment hole on your bracket that will best compensate for the angle of your transom. **NOTE:** Each adjustment hole represents a 7° increment.

Refer to Figs. 3 & 4

Adjust your bracket by removing mounting board (A). This is done by unscrewing four nuts (B) and lockwashers (C). Pull safety lock out and rotate it to the "unlocked" position. Unscrew locknut (D) and pull out pivot bolt (E). Now replace pivot bolt (E) through the desired adjustment hole in the top flange bracket (I). Reassemble unit by sliding bolt through washer (F) lower lever arm hole, spacer (G), lock bar arm hole spacer (H), lock bar arm hole, spacer (G), lower lever arm hole, washer (F) and out the other desired adjustment hole.

Secure bolt in position with nut (D); do not overtighten nut so as to bind operation of bracket. **NOTE:** Bolt must protrude through the top of the nut to insure locking. Pull safety lock out and rotate it back into the "locked" position. Replace the mounting board (A) on your bracket with washers (C) and nuts (B). Secure in position. Refer to mounting instructions.

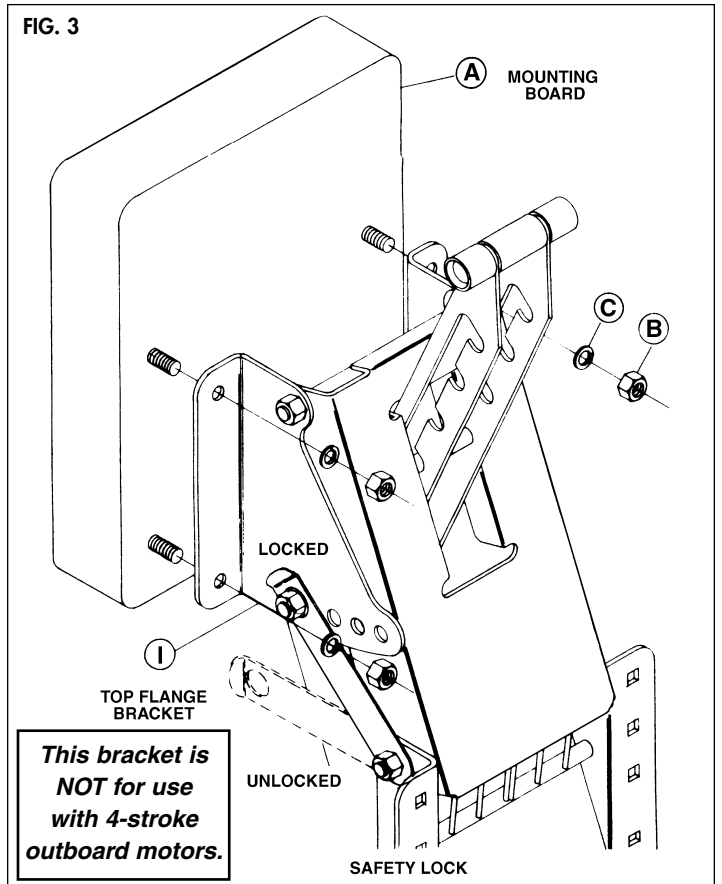

Write for
a Complete
Ezy-In Catalog

GARELICK
PO Box 8, 644 2nd Street
St. Paul Park, Minnesota 55071

Phone: 651-459-9795
E-mail: mail@garelick.com
On the Web: www.garelick.com

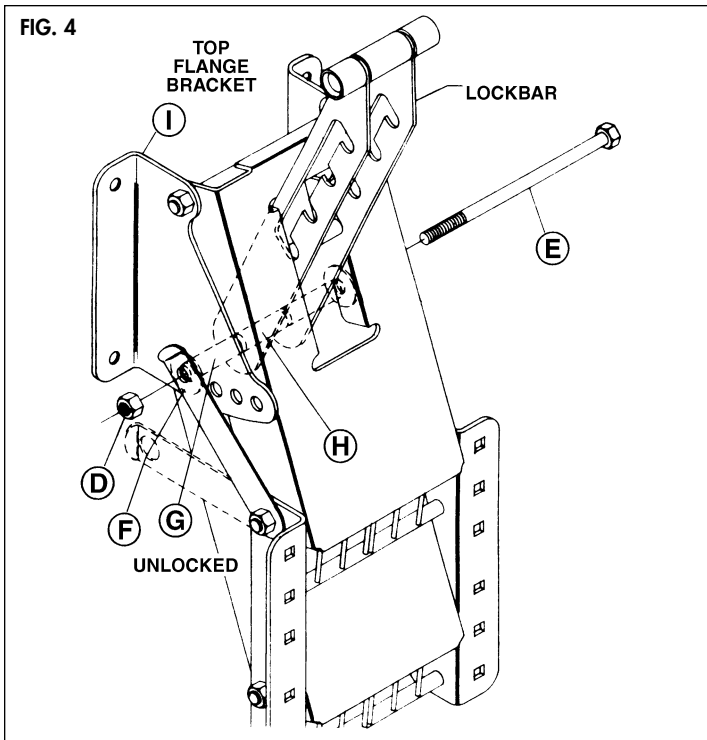

FOR POSITIVE ANGLED TRANSOMS

Refer to Figs. 5, 6 & 7

Begin the adjustment of your bracket by removing mounting board (A). This is done by unscrewing four nuts (B) and lockwashers (C). Pull safety lock out and rotate it to the "unlocked" position. Unscrew locknut (D) and pull out pivot bolt (E). Unscrew locknut (L) and pull out pivot bolt (J). Now flip the top flange brackets over and put the left bracket on the right side and the right on the left side as illustrated in Fig. 5 insert. Reattach the flange brackets to the bracket by sliding pivot bolt (E) through the lower hole in the flange bracket, (I), washer (F)

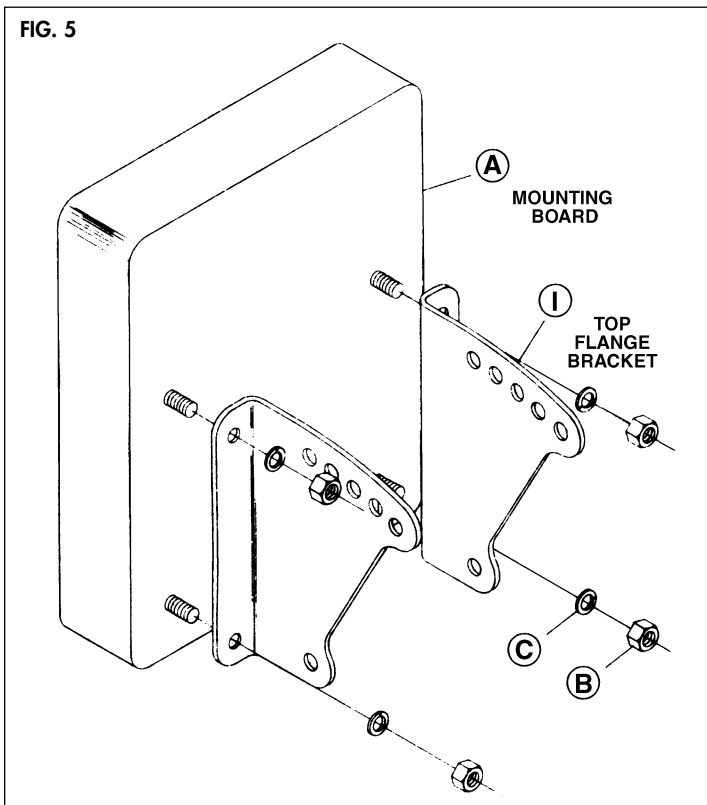

lower lever arm hole, spacer (G), lockbar arm hole, spacer (H), lock bar arm hole, spacer (G) lower lever arm hole, washer (F) and out the other lower hole in the flange bracket. Secure bolt in position with nut (D); Do not overtighten nut so as to bind operation of bracket. NOTE: Bolt must protrude through the top of the nut to insure locking.

Use the measured angle of your transom to choose the proper adjustment hole in your bracket that will best compensate for this angle. NOTE: Each adjustment hole represents a 7° increment (Refer to Fig. 7). Now, replace pivot bolt (J) through the desired adjustment hole in the top flange bracket (I). Reassemble unit by sliding bolt through washer (F), upper lever arm hole, spacer (K), upper lever arm hole, washer (F) and out other desired adjustment hole in top flange bracket. Secure bolt in position with nut (L). Now replace the mounting board (A) as pictured in Fig. 5 on your bracket with washers (C) and nuts (B). Secure in position. Move safety lock back into "locked" position. Refer to mounting instructions.

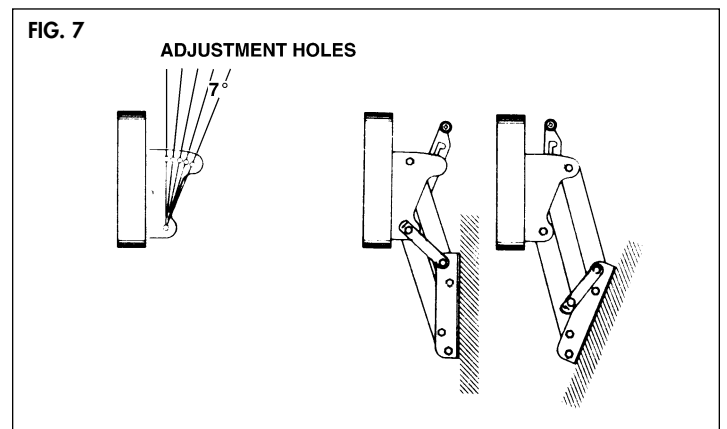
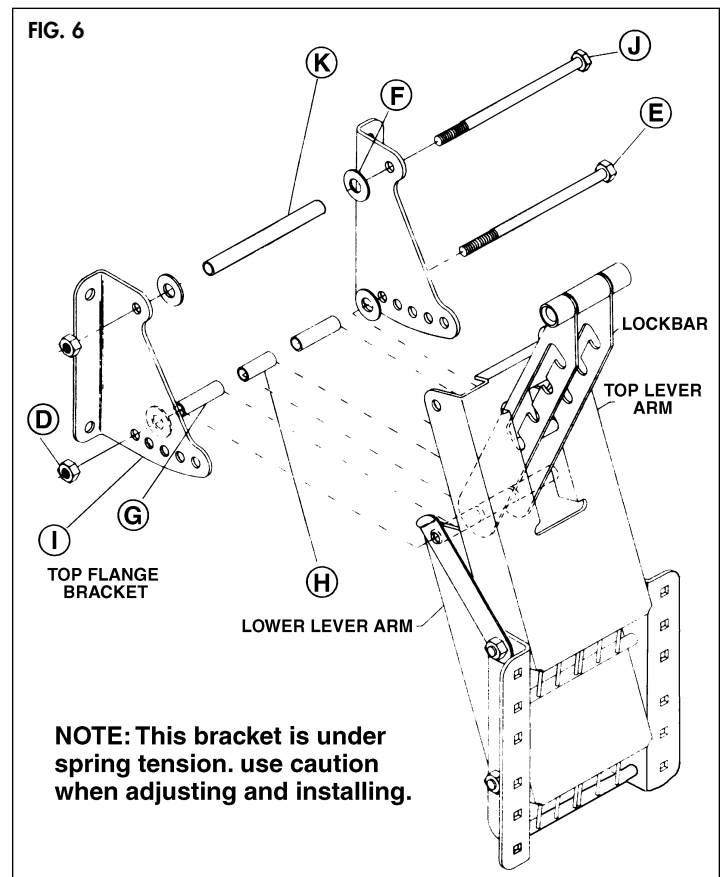

MOUNTING INSTRUCTIONS

Refer to Fig. 8

Measure the distance on your outboard motor between the cavitation plate and the upper inside edge of the mounting clamp. Subtract 2" from this length. Then add the total travel distance of your model outboard motor bracket from the table in Fig. 8 to the distance measured on your motor.

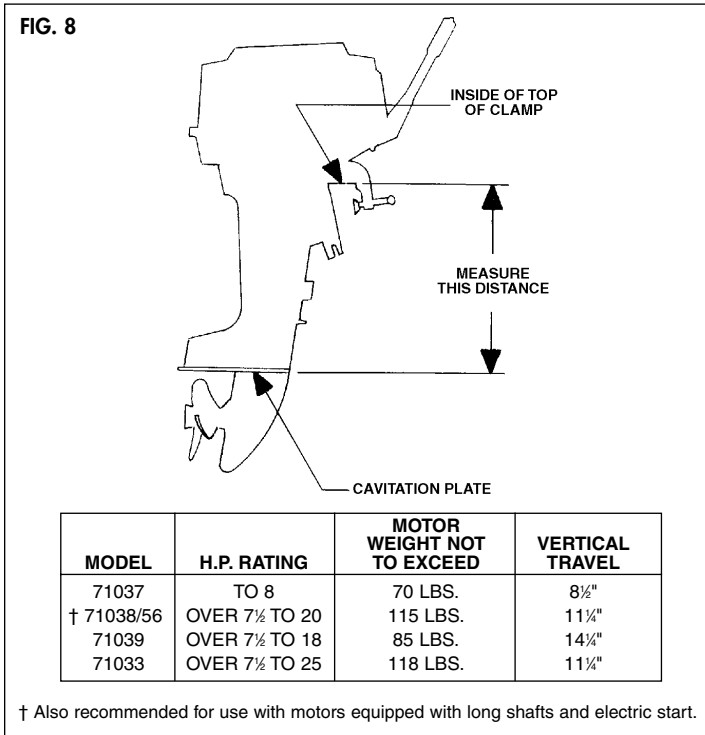

Refer to Fig. 9

Mark this total length on a stick and tape it so that the top is flush with the top of the mounting board of the motor bracket. Choose the most appropriate side of your transom for mounting the bracket. Position your bracket so it will not interfere with the turning operation of your main motor or rudder.

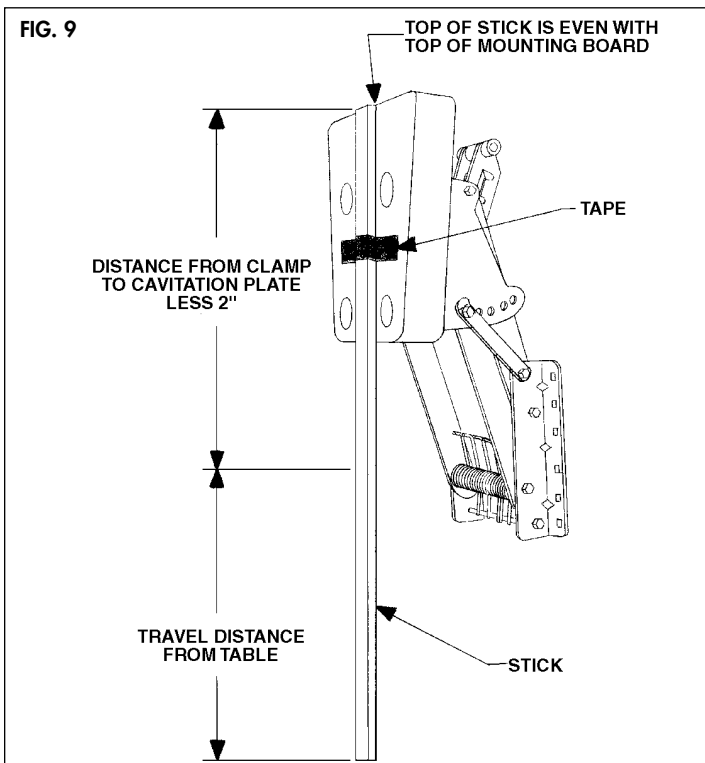

Refer to Fig. 10

For Powerboat Installation: Take your outboard motor bracket with the stick taped on and place the mounting flanges on your transom. Position the bracket so the bottom of the stick is one inch above the boat's bottom at the centerline of the outboard motor bracket.

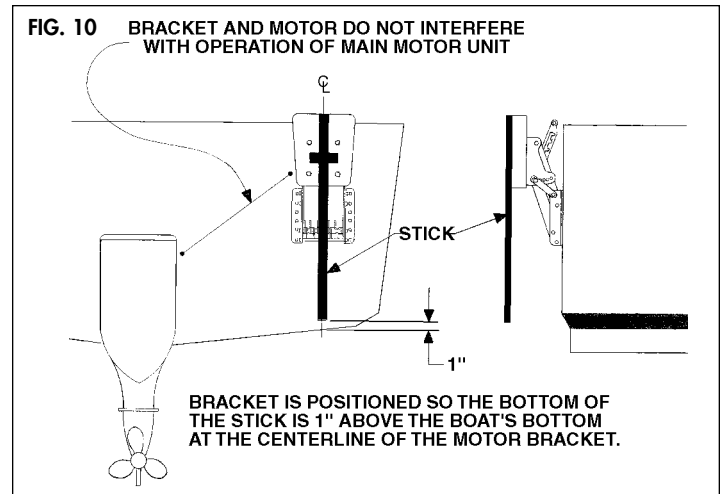

Refer to Fig. 11

For Sailboat Installation: Take your outboard motor bracket with the stick taped on and place the mounting flanges on your transom. Position the bracket so the bottom of the stick is even with the boat's actual waterline.

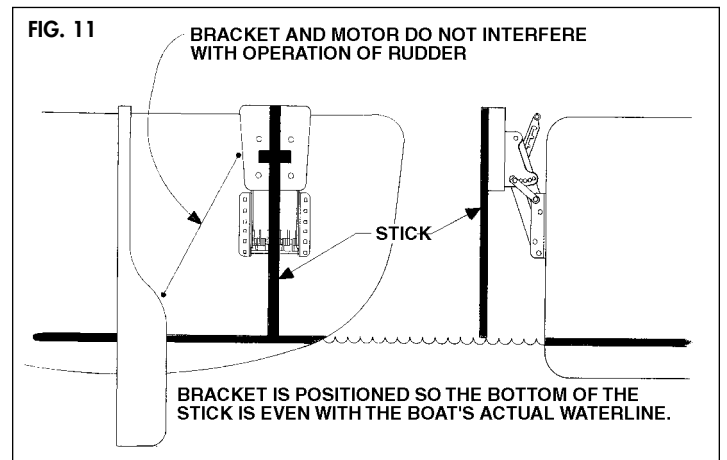

Refer to Fig. 12

After the bracket has been properly positioned mark the four outside hole locations using the bracket as a template on your transom. Drill the four marked 3/8" holes, making sure to hold the drill at right angles to the transom when drilling.

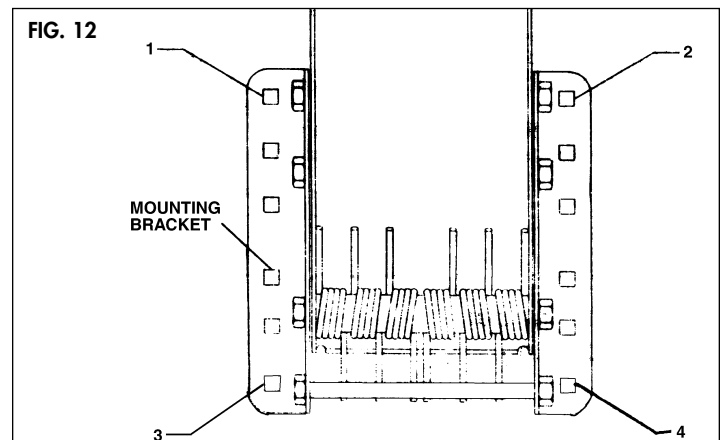

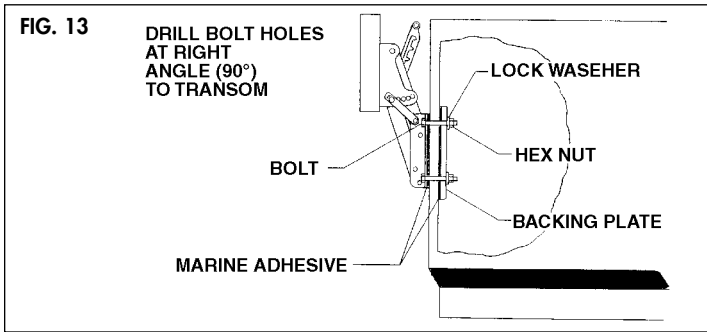

Refer to Fig. 13

If your transom is less than 2" thick, it is recommended that a backing plate be made and mounted on the inside of the transom for needed rigidity. Attach your motor bracket to the transom by coating the inside surfaces of the mounting flanges and backing plate with a marine adhesive/sealant compound and then squeeze a small amount into each bolt hole on both sides of the transom. Secure the bracket to the transom as illustrated in Fig. 13. The bracket is now ready for motor mounting.

OPERATING INSTRUCTIONS

To Lower Motor: Disengage safety lock by pulling it out and rotating it away from the locknut. Pull lever handle towards the boat to disengage locking pin. Grasp motor and SLOWLY lower it to desired height. Release lever handle; locking pin will snap forward into slot.

To Raise Motor: Pull lever handle towards the boat to disengage locking pin. Grasp motor and lift up to desired height. Release lever handle; locking pin will snap forward into slot. Engage safety lock by pulling it out and rotating it so it snaps over the pivot bolt.

AUXILIARY OUTBOARD MOTOR BRACKET IMPORTANT CAUTION GUIDELINES

1. Install motor bracket only in "up" position with safety lock in "locked" position.
2. Always remove your motor from the bracket when trailering. Failure to do so could result in damage to boat, motor and bracket.
3. Do not exceed the stated H.P. rating or weight.
4. Use a safety cable when operating your motor.
5. Operate motor at low speed.
6. Avoid turning motor at full throttle, refrain from sharp turns.
7. Operate motor in lowest position possible for best performance.
8. Always raise and tilt motor when not in use.
9. Keep pivoting bolts greased to insure smooth operation.

SPECIAL NOTE: The bracket springs counter most of the motor's weight; however, a slight push or lift may be needed. If "lowering" the bracket is too difficult due to the use of a "light" motor, it may then be desirable to decrease some spring tension. This is accomplished by cutting one but not more than three springs as illustrated in Fig. 14. Cut one spring at a time and test operation before cutting another. Make sure to cut the spring's leg as close to the coil as illustrated.

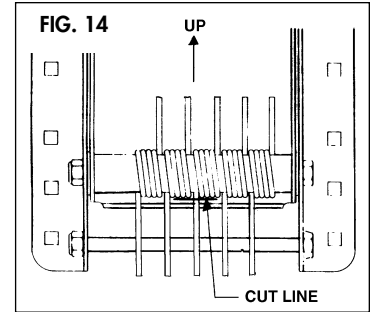

PARTS LIST

| ITEM | MODEL NO. | PART NO. | DESCRIPTION | QTY. |
|------|----------------|----------|----------------------------|------|
| A | 71033,7,8,9,56 | 06.283 | Mounting Board | 1 Ea |
| C | 71033,7,8,9,56 | 03.244 | 5/16-18x2 1/2 SS Carrbolt | 2 Ea |
| D | 71033,8,9,56 | 03.158 | 5/16-18x2 1/2 SS PB | 2 Ea |
| E | 71037 | 03.141 | 5/16-18x2 5/16 SS PB | 2 Ea |
| F | 71033,7,8,9,56 | 03.030 | SS Pronged Washer | 2 Ea |
| G | 71033,7,8,9,56 | 03.166 | 5/16-18 HX SS 1W Locknut | 4 Ea |
| H | 71037,8,9,56 | 57.051 | 71037 Short Angle Right | 1 Ea |
| I | 71033 | 57.077 | 71033 Short Angle Right | 1 Ea |
| J | 71037,8,9,56 | 57.050 | 71037 Short Angle Left | 1 Ea |
| K | 71033 | 57.076 | 71033 Short Angle Left | 1 Ea |
| L | 71033,7,8,9,56 | 03.250 | 3/8-16x5 3/4" HH SS CS | 6 Ea |
| M | 71033,7,8,9,56 | 03.252 | 1x25/64x.030 PP Washer | 8 Ea |
| N | 71033,7,8,9,56 | 06.109 | Plastic Spacer 4.8&80 | 3 Ea |
| O | 71033,7,8,9,56 | 06.107 | Plastic Spacer 1.609 | 2 Ea |
| P | 71033,7,8,9,56 | 06.108 | Plastic Spacer 1.375 | 2 Ea |
| Q | 71033,7,8,9,56 | 03.028 | 3/6-16 HX SS 1W Locknut | 6 Ea |
| R | 71033 | 57.079 | 71033 Top Plate Welded | 1 Ea |
| S | 71037 | 57.054 | 71037 Top Plate | 1 Ea |
| T | 71038,56 | 57.056 | 71038 Top Plate | 1 Ea |
| U | 71039 | 57.058 | 71039 Top Plate | 1 Ea |
| V | 71033 | 57.081 | 71033 Bottom Plate Welded | 1 Ea |
| W | 71037 | 57.055 | 71037 Bottom Plate | 1 Ea |
| X | 71038,56 | 57.057 | 71038 Bottom Plate | 1 Ea |
| Y | 71039 | 57.059 | 71039 Bottom Plate | 1 Ea |
| Z | 71033,7,8,9,56 | 49.154 | Torsion Spring (SS-71037) | 4-10 |
| AA | 71033,7,8,9,56 | 57.052 | 71037 Long Angle Left | 1 Ea |
| BB | 71033,7,8,9,56 | 57.053 | 71037 Long Angle Right | 1 Ea |
| CC | 71033,7,8,9,56 | 57.061 | 71037 Red 5/16"x4 1/2" | 1 Ea |
| DD | 71033,7,8,9,56 | 49.153 | Double Torsion Spring | 1 Ea |
| EE | 71033,7,8,9,56 | 03.253 | C17022-SS-010 Lock Washer | 1 Ea |
| GG | 71033,7,8,56 | 57.083 | Safety Latch | 1 Ea |
| HH | 71039 | 57.084 | Safety Latch | 1 Ea |
| | 71033,7,8,9,56 | 57.063 | 71037, 8,9 Hardware Pack | 1 Ea |
| | 71033,7,8,9,56 | 12.041 | SS OBMB Label #1 | 1 Ea |
| | 71037 | 12.042 | SS OBMB Label #2 | 1 Ea |
| | 71033,7,8,9,56 | 12.062 | SS Care Maint Label | 1 Ea |
| | 71033,7,8,9,56 | 12.066 | SS OBMB Caution Label | 1 Ea |
| | 71033,8,56 | 07.276 | Ctn 8 1/2"x8"x20" | 1 Ea |
| | 71037 | 07.275 | Ctn 8"x6 3/4"x19 3/8" | 1 Ea |
| | 71039 | 07.277 | Ctn 8 1/2"x8 1/2"x 22 1/4" | 1 Ea |

