



Specification Sheets for:

Direct Expansion Air Conditioning
Chilled Water Air Conditioning
Controls & Accessories
Eskimo Ice Fishbox Ice Systems

Lit. ID#	Revision Date	Description	Page
DIRECT EXPANSION AIR CONDITIONING			
Self-Contained Systems			
2502C	07/30/2010	Vector Turbo Self-Contained Series (R-410A)	3
2425C	03/25/2011	Cuddy dc Air Conditioning Kits	5
2620	01/07/2011	Dash Air Low-Profile Self-Contained	7
2769	07/30/2010	R-410A Vector Compact Self-Contained (18K & 27K BTU/hr.)	9
Split Systems			
2703A	06/04/2010	Emerald Condenser 6K-16K Series	11
2703B	11/12/2010	Emerald Condenser Multi-Ton Series	13
2696A	09/04/2009	TurboVap DX Evaporator Series	15
2696B	09/04/2009	Emerald TurboVap DX Series	17
2125	08/29/2008	CS Series Condensing Units (6K to 16K BTU/hr Capacity Range)	19
2126	08/29/2008	CS Series Multi-Ton Condensing Units (24K to 60K BTU/hr Capacity Range)	21
2855	01/14/2011	EBE Series R-410A Evaporators	23
2128	01/14/2011	EFD Two-Ton Split Evaporator	25
CHILLED WATER AIR CONDITIONING			
2135	04/09/2010	Chiller Compact	27
2735	07/30/2010	MCG Low-Profile R-410A Chillers	29
2734	01/22/2010	MCG Modular Chiller Series	31
2136	01/29/2010	SCW Staged Chilled Water	33
2467	08/29/2008	MTS 25-Ton Chiller	35
2355	12/04/2009	AT Air Handlers for Chilled Water	37
2426A	01/28/2011	Super Quiet AT-DC Air Handlers for CW	39
2546	01/14/2011	ATL Air Handlers for CW	41
2562	05/15/2009	ABL Air Handlers for CW	43
2564	01/07/2011	ATV Air Handlers for CW	45
2404	05/02/2008	AT-MU Fresh Air Make-Up Units	47
2704	09/04/2009	Fresh Air Make-Up & Extraction Units (by Condaria)	49
CONTROLS			
2237	09/03/2010	Elite™ & AH-Elite Digital Control	51
2630	02/04/2011	Passport® I/O Compact Digital Control	53
2133	08/29/2008	Chilled Water Master Controller	55
2345	08/29/2008	CWLC for Chilled Water Systems	57
AIR CONDITIONING ACCESSORIES			
2701	10/22/2010	In-Duct Breathe Easy™ Air Purifiers	59
2712	07/30/2010	Portable Breathe Easy™ Air Purifiers	61
2698	08/07/2009	Breathe Easy™ Air Filters	63
2700	01/07/2011	Power Up With SmartStart™	65
2263	08/13/2010	March Marine Centrifugal Seawater Pumps	67
2129	08/13/2010	Seawater Pumps	69
2134	01/29/2010	Pilot-House Defroster	71
2413	04/22/2011	Variable Frequency Drive	73
2541	04/09/2010	Pump Packages for Chilled Water	75
2130	08/29/2008	Supply & Return Air Grilles	77
2131	08/29/2008	Ducting & Transition Boxes	79
DOMETIC MARINE AIR CONDITIONING			
2628	08/06/2010	Dometic EnviroComfort Kits	81
2631	08/06/2010	Dometic EnviroCool Kits	83
2544	04/29/2009	DuraSea Condensing Units	85
2132	07/17/2009	Radome Environmental Control Units	87
ESKIMO ICE SYSTEMS			
2450	02/11/2011	Eskimo Ice Ice Systems	89
2617	08/21/2009	Ice Cube Fishbox Ice System	91

Now Available
With R-410A

Vector Turbo Self-Contained Series

Powerful, Quiet & Compact With No Drain Pan Worries

Photo courtesy of Cruisers Yachts



VTD16K Vector Turbo shown
with optional sound cover



The Vector Turbo series completely revolutionized self-contained cooling and heating with the newest innovations in marine air conditioning system design.

The rust-free molded composite drain pan has three drains for the rapid removal of condensate water.

An advanced cushioning system results in significantly quieter, virtually vibration-free operation. The enclosed blower motor eliminates overhang to provide easier installation.

The Turbo series was specifically engineered to harness and maximize the impressive performance of R-410A refrigerant. Used in the HVAC industry for more than 10 years, R-410A refrigerant is proven, reliable, and complies with all EPA standards and is accepted world wide.

Easy-to-install sound cover provides up to 50% noise reduction



Make a quiet system even quieter. These compact, easy-to-install sound covers are available for all Vector Turbo models.

The cover fits over the compressor, providing a 3- to 5-dB noise reduction—which is about a 50% drop in what the human ear can perceive. Installation takes just minutes and all mounting hardware is included.

Key Benefits

- Up to 27% more energy efficient.
- Up to 21% increased capacity.
- Compact design uses less space.
- Rust-free drain pan.
- Up to 85% less standing water in drain pan.
- Reduced noise and vibration with high-velocity blowers and mounts.
- Optional sound cover further reduces compressor noise by up to 50%.
- Engineered to maximize performance of R-410A, an environmentally safe refrigerant.

Customer comment:

"There is very little noise coming from the compressor, and vibrations are practically non-existent. I highly recommend this unit."

— Bob Silverman, owner,
305 Bayliner Express Cruiser

Technical Specifications for Vector Turbo Series

Model ⁽¹⁾	VTD8K			VTD10K			VTD12K			VTD16K					
	6,000	8,000	10,000	115	230	240	115	230	240	115	230	240	115	230	240
Capacity (BTU/hr) ⁽²⁾	115	230	240	115	230	240	115	230	240	115	230	240	115	230	240
Voltage (VAC)	60/1	60/1	50/1	60/1	60/1	50/1	60/1	60/1	50/1	60/1	60/1	50/1	60/1	60/1	50/1
Cycle (Hz)/Phase (Ph) ⁽³⁾	4.60	2.20	2.70	5.50	3.10	3.20	6.70	3.30	2.90	8.70	4.00	3.30	10.40	5.10	4.60
Full Load Amps (FLA) cool	5.90	2.80	3.70	7.10	4.00	4.10	8.80	3.90	3.80	10.90	5.10	4.30	13.60	6.60	6.00
Full Load Amps (FLA) heat	0.80	0.36	0.36	1.31	0.70	0.83	1.14	0.61	0.48	1.14	0.61	0.48	1.61	0.78	0.56
Blower (FLA)	36.00	17.70	17.70	36.00	17.70	17.70	42.00	22.00	18.80	58.00	28.00	21.00	62.00	34.00	22.00
Locked Rotor Amps (Comp)	0.88	0.64	0.88	0.82	0.92	0.99	1.02	0.90	0.91	1.26	1.18	1.03	1.57	1.51	1.43
K.V.A. (Kilo-Volt-Amps)	20	11	10	21	11	11	27	16	14	34	18	14	42	20	20
Max. Circuit Breaker (Amps)	11	6	6	12	6	6	16	9	8	19	10	8	24	12	11
Min. Circuit Ampacity (Amps)	8.5/241	8.5/241	8.5/241	9.0/255	9.5/269	9.5/269	11.0/312	11.0/312	11.0/312	10.5/298	11.0/312	11.5/326	13.0/369	13.0/369	13.0/369
Refrigerant R-410A (oz/g)															
Unit Dimensions (in/mm)⁽⁴⁾															
Height – Evaporator (C)	10.8/274	10.8/274	10.8/274	10.8/274	10.8/274	10.8/274	10.8/274	10.8/274	10.8/274	10.8/274	10.8/274	10.8/274	10.8/274	10.8/274	10.8/274
Height – Compressor (D ¹)	11.1/282	11.1/282	11.1/282	11.1/282	11.1/282	11.1/282	11.1/282	11.1/282	11.1/282	11.1/282	11.1/282	11.1/282	11.1/282	11.1/282	11.1/282
Height – w/opt. Sound Cover	13.4/340	13.4/340	13.4/340	13.4/340	13.4/340	13.4/340	13.4/340	13.4/340	13.4/340	13.4/340	13.4/340	13.4/340	13.4/340	13.4/340	13.4/340
Width (A ¹)	17.6/447	17.6/447	17.6/447	17.6/447	17.6/447	17.6/447	17.6/447	17.6/447	17.6/447	17.6/447	17.6/447	17.6/447	17.6/447	17.6/447	17.6/447
Depth (B ¹)	10.7/272	10.7/272	10.7/272	10.7/272	10.7/272	10.7/272	10.7/272	10.7/272	10.7/272	10.7/272	10.7/272	10.7/272	10.7/272	10.7/272	10.7/272
Min. Duct Size Ø (in/mm)	4/102	4/102	4/102	4/102	4/102	4/102	4/102	4/102	4/102	4/102	4/102	4/102	4/102	4/102	4/102
Min. SA Grille (sq. in./sq. cm.)	32/206	32/206	32/206	32/206	32/206	32/206	32/206	32/206	32/206	32/206	32/206	32/206	32/206	32/206	32/206
Min. RA Grille (sq. in./sq. cm.)	64/413	64/413	64/413	64/413	64/413	64/413	64/413	64/413	64/413	64/413	64/413	64/413	64/413	64/413	64/413
Net Weight (lbs/kg)	43.4/19.7	43.4/19.7	43.4/19.7	46.7/21.2	46.7/21.2	46.7/21.2	49.6/22.5	49.6/22.5	49.6/22.5	53.0/24.0	53.0/24.0	53.0/24.0	59.6/27.0	59.6/27.0	69.6/31.6
Gross Weight (lbs/kg)	53.4/24.2	53.4/24.2	53.4/24.2	56.7/25.7	56.7/25.7	56.7/25.7	59.6/27.0	59.6/27.0	59.6/27.0	63.0/28.6	63.0/28.6	63.0/28.6	69.6/31.6	69.6/31.6	69.6/31.6

Notes:

⁽¹⁾ Add a 'Z' after the capacity designator for 230V units. Examples VTD8K = 115V, VTD8KZ=230V, VTD8KZ50=220V/50Hz.

⁽²⁾ BTU and electrical data are based on a 45°F/7.2°C evaporator and 100°F/37.8°C condenser in cool mode, and a 45°F/7.2°C evaporator and 130°F/54.4°C condenser in heat.

⁽³⁾ 60Hz units must not operate at 50Hz and 50Hz units must not operate at 60Hz unless data plate states otherwise.

⁽⁴⁾ Electric box is remote mounted up to 34" (864 mm) away from compressor. Electrical box dimensions are 2.7" (69 mm) x 6.5" (165 mm) x 8.8" (224 mm).

[†] Refers to callouts shown in drawing below.

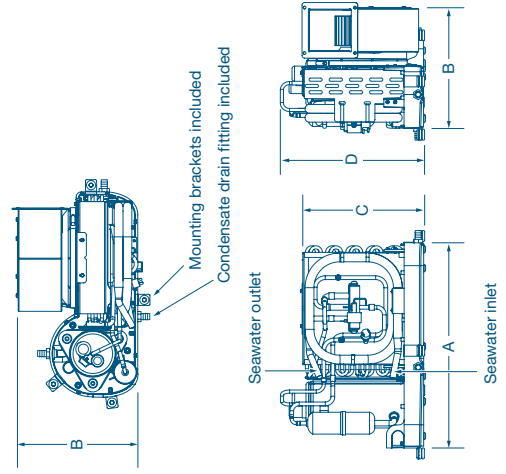

Dealer:

DOMETIC MARINE DIVISION
 2000 N. Andrews Ave. Ext. J Pompano Beach, FL 33069 USA | 954-973-2477 | Fax 954-979-4414
 www.DometicUSA.com | MarineSales@DometicUSA.com

24/7 Tech Support for United States & Canada:
 8:00 AM to 5:00 PM Eastern Time: 800-542-2477
 After hours and weekends: 888-440-4494

International Sales & Service:
 Europe & the Middle East: Call +44(0)870-330-6101
 For all other areas visit our website to find your nearest distributor.



Cuddy dc Air Conditioning Kits

Easy & Affordable Cold Air for Smaller Cabins

Photo courtesy of Pro-Line Boats



Cuddy dc 3,500
BTU/hr Kit

The Dometic Cuddy dc is a compact 3,500 BTU/hr cool-only air conditioner designed to work with 12V power systems. Energized by a dedicated bank of batteries and a dedicated power module (DPM), the Cuddy dc makes your small cabin a refuge from the heat and sun. Compact—about the size of a typical battery box—this low-profile unit easily fits beneath a V-berth or in a storage area below deck. The Cuddy dc uses R-134A, a globally accepted, environmentally safe refrigerant.

Your dedicated 12V DC battery bank powers the system via the Dometic DPM. Two ABYC-approved wires (sized properly for your unique installation) run from the dedicated battery bank to the DPM. Easy-to-use polarized plugs connect the DPM to the seawater pump and the Cuddy dc unit. Optional cables are available for longer runs if your setup requires more than the standard 4.5 ft. (1.37 m) cable included with the kit.

To operate the system, the Cuddy dc uses a simple two-knob mechanical control. Since it draws no power itself, the mechanical control maximizes runtime and efficiency. The Cuddy dc system (compressor, blower, and pump) draws about 29 amps of DC power under normal operating conditions. Supplemental DC power comes to you via engine power (if available) or via shore power through a battery charger.

Key Benefits

- Designed for small cabins.
- Operates via simple 12V DC connections.
- Compact—about the size of a battery box.
- High-velocity blower with split capacitor for greater airflow.
- Stainless-steel chassis.
- Simple two-knob mechanical control maximizes efficiency and runtime.
- Minimal DC draw (about 29 DC amps total).
- No genset needed.
- Air distribution kits available.

Technical Specifications for Cuddy dc Kits

Component	Capacity	Dimensions (in/mm)			Weight (lbs./kg.)	Refrigerant	Electrical (Compressor, Blower, and PML 150 Pump)
		Height	Width	Depth			
Cuddy dc Unit	3,500 BTU/hr	9.25/235	15.00/381	8.0/204	29.0/13.2	R-134A	~29 amps ⁽¹⁾ (12V DC)
Dedicated Power Module (DPM)	N/A	5.13/130	10.00/254	2.67/68	3.0/1.3	—	
Control	N/A	5.50/140	3.25/83	2.75/70	—	—	
Seawater Pump	150 GPH	2.75/70	3.50/89	4.75/121	1.0/0.46	—	

Notes:
⁽¹⁾ Actual load is dependent upon humidity, seawater temperature, battery condition, voltage, and electrical connections.

Cuddy dc Kits & Accessories

Cuddy dc – 12V DC system	Cooling-only unit, DPM, 150 GPH seawater pump, control, polarized plugs
Extension cable	DPM to Unit - 10' (3m)
Extension cable	DPM to Unit - 20' (6m)
Extension cable	PLM 250 to Unit - 10' (3m)
Air Distribution Kit – Black	3" discharge grille - black; 8" X 8" (204mm X 204mm) return grille; 10' (3m) of 3" duct
Air Distribution Kit – White	3" discharge grille - white; 8" X 8" (204mm X 204mm) return grille; 10' (3m) of 3" duct

Dedicated Power Module

Our Cuddy dc kit includes a Dedicated Power Module (DPM) that has been Dometic-tested to handle the air conditioning load.

Batteries & Battery Charger

You must provide the right type of batteries and the right type of battery charger. Use only Deep-Cycle AGM or Gel-Cell batteries. (Do not use Wet-Cell batteries.) The battery charger must be rated for the type of battery you use. The Cuddy dc requires a dedicated battery bank. To maximize run-time, we recommend using at least two batteries in the bank. (The more cells, the longer the runtime.) All batteries used must be of the same type (either all AGM or all Gel Cell), the same capacity, and the same age.

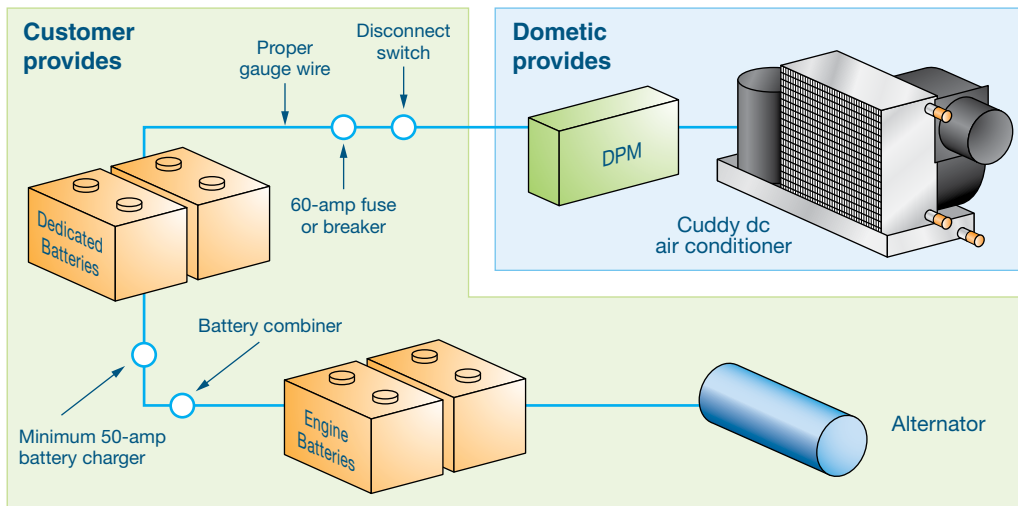

DOMETIC MARINE DIVISION

2000 N. Andrews Ave. Ext. I Pompano Beach, FL 33069 USA | 954-973-2477 | Fax 954-979-4414
 www.DometicUSA.com | MarineSales@DometicUSA.com

24/7 Tech Support for United States & Canada:

8:00 AM to 5:00 PM Eastern Time: 800-542-2477
 After hours and weekends: 888-440-4494

International Sales & Service:

Europe & the Middle East: Call +44(0)870-330-6101
 For all other areas visit our website to find your nearest distributor.



Environmentally Responsible

Dealer:

Now Available
With R-410A

Stay Cool With Dash Air

For Flybridge, Cockpit & On-Deck Installations



VLD16K self-contained model

Dash Air delivers high-velocity cold air (or HOT!) onto the bridge, cockpit, or deck using an innovative horizontal compressor. The 16,000 BTU/hr. self-contained package stands just eight inches (203 mm) high and is easily ducted to confined spaces like flybridge dashboards and consoles.

Dash Air air conditioning systems use R-410A, an environmentally safe refrigerant with exceptional thermodynamic properties that maximize system efficiency.

Also available is a 16,000 BTU/hr. evaporator connected to a remote condensing unit below decks.

All Dash Air systems are reverse-cycle, blowing warm air on chilly days, thereby extending your cruising season. All units are designed for easy, professional installation on new boats and older vessels.

Dash Air features an oversized four-row evaporator coil for excellent heat removal under low fan-speed conditions. A highly efficient blower reduces power consumption, and the blower flows to two outlets.

Key Benefits

- Innovative horizontal compressor requires only 8 in. (203 mm) of height for installation.
- 16,000 BTU/hr. in a high-velocity unit.
- Highly-efficient dual blowers.
- Flybridge, cockpit and on-deck installations.
- Environmentally safe R-410A refrigerant.
- 304-grade stainless-steel drain pan for long service life.
- Stainless-steel condensate drains for excellent water removal.
- Condensate under evaporator to minimize sloshing and remove water rapidly.
- Remote electrical box with 5 ft. (1.52 m) harness.
- Special corrosion-resistant coating on blower and housing.
- Oversized four-row evaporator coil for excellent heat removal under low fan-speed conditions.

Technical Specifications for R-410A Dash Air Systems

Unit Type	Self-Contained Units			Split Evaporator	
Capacity (BTU/hr.) ⁽¹⁾	16,000			16,000	
Model Number	VLD16K	VLD16KZ	VLD16KZ50	EDLE16-115V	EDLE16-230V
Voltage (VAC)	115	230	240	115	230
Cycle (Hz)/Phase (Ph) ⁽²⁾	60/1	60/1	50/1	60/1	60/1 & 50/1
Blower Amps	2.00	0.86	0.62	2.00	0.86 @ 230V/60Hz 0.62 @ 230V/50Hz
Full Load Amps (FLA) cool	11.0	4.7	4.5	N/A	
Full Load Amps (FLA) heat	14.2	6.2	5.8	N/A	
Locked Rotor Amps (Comp)	61	29	26	N/A	
K.V.A. (Kilo-Volt-Amps)	1.63	1.42	1.40	0.23	0.20
Max. Circuit Ampacity (Amps)	35	20	20	5	4
Min. Circuit Ampacity (Amps)	23	14	13	3	2
Refrigerant R-410A (oz/g)	16.0/454	15.0/425	15.5/439	N/A	N/A
Dimensions (in/mm)					
Height	8.00/203			7.40/188	
Width	30.25/768			22.25/566	
Depth	14.00/356			11.00/280	
Min. Duct Size Ø	7.0/178			7.0/178	
Min. SA Grille (sq. in./cm.)	80/516			80/516	
Min. RA Grille (sq. in./cm.)	160/1032			160/1032	
Net Weight (lbs/kg)	70/154			19/9	
Gross Weight (lbs/kg)	80/176			29/13	

⁽¹⁾ BTU and electrical data are based on a 45°F (7.2°C) evaporator and 100°F (37.8°C) condenser in cool mode, and a 45°F (7.2°C) evaporator and 130°F (54.4°C) condenser in heat mode.

⁽²⁾ Note: 60Hz units must not operate at 50Hz and 50Hz units must not operate at 60Hz unless data plate says otherwise.

Available Custom Air Flow Accessories:

- #229000005 PLNM AMN RA VLD16/2@5" Side Discharge Plenum
- #229000006 PLNM AMN RA VLD16/2@5" Upward Discharge Plenum
- #229000007 PLNM AMN RA VLD16/2@5" Downward Discharge Plenum
- #228700089 Ring ABS trans 5"-OB Short Flange

Dimensions for Self-Contained Dash Air

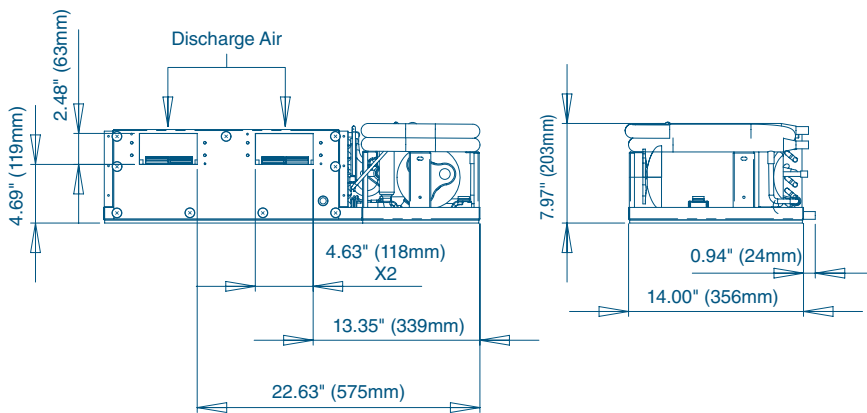

DOMETIC MARINE DIVISION

2000 N. Andrews Ave. Ext. I Pompano Beach, FL 33069 USA | 954-973-2477 | Fax 954-979-4414
 www.DometicUSA.com | MarineSales@DometicUSA.com

24/7 Tech Support for United States & Canada:

8:00 AM to 5:00 PM Eastern Time: 800-542-2477
 After hours and weekends: 888-440-4494

International Sales & Service:

Europe & the Middle East: Call +44(0)870-330-6101
 For all other areas visit our website to find your nearest distributor.



Environmentally Responsible

Dealer:

R-410A Vector Compact®

18K & 27K BTU/hr Self-Contained Systems



VCD27K-HV-410A

The Vector Compact series of self-contained marine air conditioners offers 18K and 27K BTU/hr of cooling and heating.

These high-capacity units were engineered to harness and maximize the impressive performance of environmentally safe R-410A refrigerant. Used in the HVAC industry for more than 10 years, R-410A refrigerant is proven and reliable, and complies with all EPA standards and is accepted worldwide.

All models offer direct expansion operation in a compact, low-profile unit, with a seawater-cooled condenser and choice of controls. Vector Compact units are designed for installation under a settee or berth, in a locker or cabinet, or other convenient location.

Vector Compact systems feature high-velocity (HV) blowers. All blowers are insulated to prevent secondary condensation, and are fully rotatable for flexibility during installation.

Key Benefits

- Compact design reduces unit size by up to 25% of the original Vector Rotary's size.
- High-velocity, fully-insulated blowers.
- Fully rotatable blowers.
- Patented design increases cooling capacity and dehumidification.
- Unique compressor and reversing valve mounting reduces vibration.
- Electrical box installed on unit within footprint dimensions eliminates additional installation labor and space requirements.
- High-efficiency rotary (18K) and scroll (27K) compressors are quiet and more reliable.
- Condenser coil's cupronickel-encased copper shell provides maximum heat transfer and high corrosion resistance.
- Evaporator coil employs an enhanced fin design and rifled copper tubing to provide maximum capacity.

Technical Specifications for R-410A Vector Compact®

Model ⁽¹⁾	VCD18K/1-HV-410A			VCD27K-HV-410A	
Capacity BTU/hr ⁽²⁾	18,000			27,000	
Voltage (VAC)	115	208-230	220-240	208-230	220-240
Cycle (Hz)/Phase (Ph) ⁽³⁾	60/1	60/1	50/1	60/1	50/1
Full Load Amps (FLA) Cool	11.1	6.1	5.5	7.9	9.0
Full Load Amps (FLA) Heat	15.1	8.0	6.8	11.1	12.6
Locked Rotor Amps (Comp)	66.0	32.0	26.0	58.3	61.0
Kilo-Volt-Amps (KVA)	1.8	1.9	1.6	2.6	3.1
Max. Circuit Breaker (Amps)	45.0	20.0	20.0	45.0	45.0
Min. Circuit Ampacity (Amps)	27.0	12.0	12.0	27.0	26.0
R-410A Refrigerant (oz/kg)	17.0/0.482		16.5/0.468	23.5/667.0	23.0/652.0
Height – Evaporator (in/mm)	14.00/356			18.00/457	
Height – Blower (in/mm) ⁽⁴⁾	15.50/394			19.25/489	
Width (in/mm)	12.00/305			15.25/387	
Depth (in/mm)	21.00/533			24.75/629	
Motor Overhang (in/mm)	1.00/25 ⁽⁵⁾			N/A	
Min. Duct Size Ø (in/mm)	7.00/178			8.00/203	
Min. Supply Grille (in ² /cm ²)	100.00/645			140.00/903	
Min. Return Grille (in ² /cm ²)	200.00/1290			240.00/1548	
Net Weight (lbs/kg)	63.8/28.9			120.0/54.4	
Gross Weight (lbs/kg)	73.0/33.1			130.0/58.9	

Notes:

- ⁽¹⁾ VCD indicates Elite or Passport I/O climate controls; VCM indicates mechanical controls.
- ⁽²⁾ BTU and electrical data are based on a 45°F/7.2°C evaporator and 100°F/37.8°C condenser in cool mode, and a 45°F/7.2°C evaporator and 130°F/54.4°C condenser in heat.
- ⁽³⁾ 60Hz units must not operate at 50Hz and 50Hz units must not operate at 60Hz unless data plate states otherwise.
- ⁽⁴⁾ Height with blower in the horizontal position. Overall height can be reduced by rotating blower downward.
- ⁽⁵⁾ Motor is inside blower on HV units. However, allow 1.00"/25mm for blower ring flange on that side.

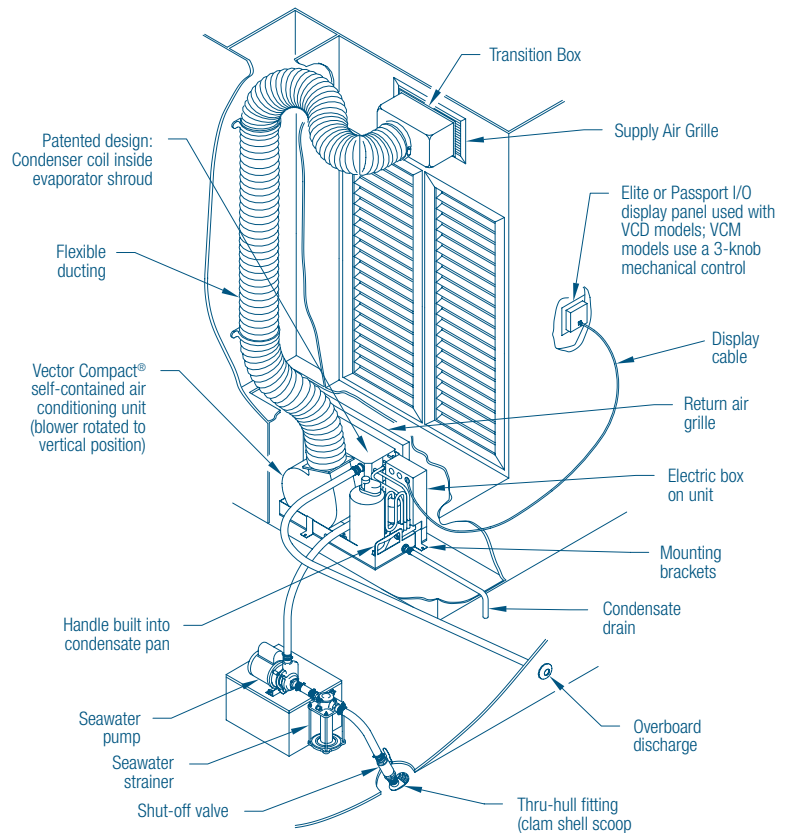
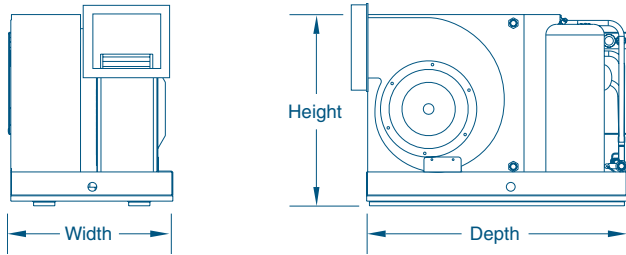

DOMETIC MARINE DIVISION

2000 N. Andrews Ave. Ext. I Pompano Beach, FL 33069 USA | 954-973-2477 | Fax 954-979-4414
 www.DometicUSA.com | MarineSales@DometicUSA.com

24/7 Tech Support for United States & Canada:

8:00 AM to 5:00 PM Eastern Time: 800-542-2477
 After hours and weekends: 888-440-4494

International Sales & Service:

Europe & the Middle East: Call +44(0)870-330-6101
 For all other areas visit our website to find your nearest distributor.



Environmentally Responsible

Dealer:

Emerald Condenser 6K-16K Series

Innovative Chassis Conquers Installation Challenges

Photo courtesy of Viking Yachts



ED12 shown

After listening to boat builders, global service teams and boat owners, Dometic engineers designed a totally innovative Emerald Condenser series to harness and maximize the impressive performance of R-410A refrigerant while meeting all international clean air standards.

The increase in BTU capacity is due primarily to the improved refrigerant metering design. The bi-flow thermal expansion valve for cooling provides up to a 14% increase in system capacity, which, when combined with a separate metering system for heating, attains an increase of up to 10% in heating performance. The amperage reduction of up to 27% is due to the more efficient design of the rotary compressor and properly sized refrigerant components.

The Emerald Condenser has a minimized footprint. This compact design incorporates built-in isolation, two large drain connections and numerous mounting options for installation to a smooth deck, stringer or existing rack. The incorporated lifting handles and smooth bottom allows for easy lifting and quick placement of the unit. The molded composite no-rust drain pan is shaped to provide positive drainage even when the boat heaves and rolls. The amount of standing water in the drain pan is reduced by up to 85%, which is 8x times less than a typical drain pan.

The condensing unit provides quick and easy installation. The drain, seawater and refrigerant connections are conveniently located to conquer installation challenges thus reducing installation time by up to fifteen minutes. The electrical box can be easily removed and located up to 5 ft. (1.5 m) away, further reducing the size of the unit while making the system more accessible. The reversing valve, pressure switches and service ports are centrally located, high on the unit for access from any side.

Key Benefits

- Up to 17.5% increase in BTU capacity.
- Up to 41% amperage reduction.
- Up to 32% reduced start-up amps.
- Up to 16% smaller.
- Up to 25% lighter.
- Up to 85% reduction in condensate in the drain pan.
- Up to 15 minutes faster to install.
- Square chassis for easy installation in tight locations.
- Three mounting options adapt to installation environments.
- Composite drain pan will not rust.
- Reconfigurable chassis allows optimal drain connection locations.
- Built-in refrigerant-line filter drier reduces installation time and protects compressor from moisture and contaminants.
- High-performance engineering maximizes the efficiency of R-410A refrigerant.
- Available in capacities ranging from 6K to 48K BTU/hr.

Technical Specifications for Emerald Condenser 6K-16K Series

Model ⁽¹⁾	ED6			ED8			ED10			ED12			ED16		
	115/60/1	230/60/1	240/50/1	115/60/1	230/60/1	240/50/1	115/60/1	230/60/1	240/50/1	115/60/1	230/60/1	240/50/1	115/60/1	230/60/1	240/50/1
Capacity (BTU/Hr)	6,000	8,000	10,000	10,000	12,000	13,000	13,000	13,000	13,000	13,000	13,000	13,000	13,000	13,000	13,000
Power (Volt/Hz/Ph)	3.8	1.8	2.4	2.4	2.4	2.4	2.4	2.4	2.4	2.4	2.4	2.4	2.4	2.4	2.4
Full Load Amps (FLA) – Cool	5.1	2.4	3.3	3.3	3.3	3.3	3.3	3.3	3.3	3.3	3.3	3.3	3.3	3.3	3.3
Full Load Amps (FLA) – Heat	36.0	17.7	17.7	17.7	17.7	17.7	17.7	17.7	17.7	17.7	17.7	17.7	17.7	17.7	17.7
Locked Rotor Amps	20.0	10.0	10.0	10.0	10.0	10.0	10.0	10.0	10.0	10.0	10.0	10.0	10.0	10.0	10.0
Max. Circuit Breaker (Amps)	R-410A	R-410A	R-410A	R-410A	R-410A	R-410A	R-410A	R-410A	R-410A	R-410A	R-410A	R-410A	R-410A	R-410A	R-410A
Refrigerant Type	1.5/5.7	2.0/7.6	2.5/9.5	2.5/9.5	2.5/9.5	2.5/9.5	2.5/9.5	2.5/9.5	2.5/9.5	2.5/9.5	2.5/9.5	2.5/9.5	2.5/9.5	2.5/9.5	2.5/9.5
Seawater Flow (gpm/lpm)	Unit Dimensions (in/mm)														
Height	12.0/305	12.0/305	13.0/330	13.0/330	13.0/330	13.0/330	13.0/330	13.0/330	13.0/330	13.0/330	13.0/330	13.0/330	13.0/330	13.0/330	13.0/330
Width	13.3/338	13.3/338	13.3/338	13.3/338	13.3/338	13.3/338	13.3/338	13.3/338	13.3/338	13.3/338	13.3/338	13.3/338	13.3/338	13.3/338	13.3/338
Depth 1 ²	13.3/338	13.3/338	13.3/338	13.3/338	13.3/338	13.3/338	13.3/338	13.3/338	13.3/338	13.3/338	13.3/338	13.3/338	13.3/338	13.3/338	13.3/338
Depth 2 (w/elec. box) ³	15.1/384	15.1/384	15.1/384	15.1/384	15.1/384	15.1/384	15.1/384	15.1/384	15.1/384	15.1/384	15.1/384	15.1/384	15.1/384	15.1/384	15.1/384
Sea Water (in. and type)	Connections Ø														
Discharge	5/8" hose clamp	5/8" hose clamp	5/8" hose clamp	5/8" hose clamp	5/8" hose clamp	5/8" hose clamp	5/8" hose clamp	5/8" hose clamp	5/8" hose clamp	5/8" hose clamp	5/8" hose clamp	5/8" hose clamp	5/8" hose clamp	5/8" hose clamp	5/8" hose clamp
Suction	1/4"	1/4"	1/4"	1/4"	1/4"	1/4"	1/4"	1/4"	1/4"	1/4"	1/4"	1/4"	1/4"	1/4"	1/4"
	3/8"	3/8"	3/8"	3/8"	3/8"	3/8"	3/8"	3/8"	3/8"	3/8"	3/8"	3/8"	3/8"	3/8"	3/8"
Net Weight	43.0/19.5	43.0/19.5	43.0/19.5	43.0/19.5	43.0/19.5	43.0/19.5	43.0/19.5	43.0/19.5	43.0/19.5	43.0/19.5	43.0/19.5	43.0/19.5	43.0/19.5	43.0/19.5	43.0/19.5
Gross Weight	50.0/22.7	50.0/22.7	52.0/23.6	52.0/23.6	52.0/23.6	52.0/23.6	52.0/23.6	52.0/23.6	52.0/23.6	52.0/23.6	52.0/23.6	52.0/23.6	52.0/23.6	52.0/23.6	52.0/23.6

Notes:
 (1) ED models have a Passport I/O control. For units with a mechanical control, replace the "D" with "M", e.g. "EM16".
 (2) Actual unit depth when electrical box is mounted remotely.
 (3) Combined depth of unit and electrical box, as shown in the drawing below.

* Please refer to spec sheet L-2703B for the Emerald Condenser 24K-48K Series.

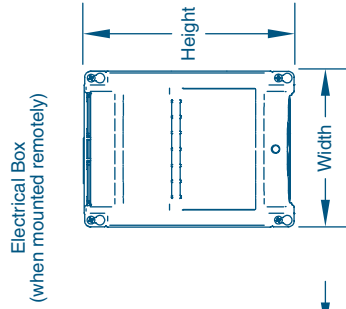
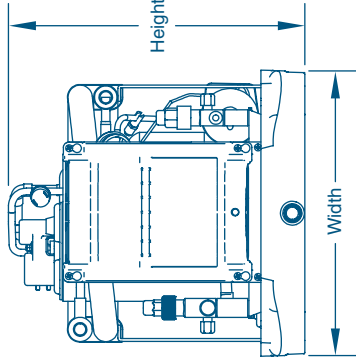
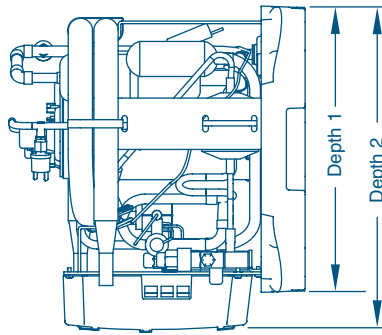

Electrical Box Dimensions (in/mm)

Height	Width	Depth
8.75/222	6.50/165	2.63/67

DOMETIC MARINE DIVISION
 2000 N. Andrews Ave. Ext. J Pompano Beach, FL 33069 USA | 954-973-2477 | Fax 954-979-4414
www.DometicUSA.com | MarineSales@DometicUSA.com

24/7 Tech Support for United States & Canada:
 8:00 AM to 5:00 PM Eastern Time: 800-542-2477
 After hours and weekends: 888-440-4494

International Sales & Service:
 Europe & the Middle East: Call +44(0)870-330-6101
 For all other areas visit our website to find your nearest distributor.

L-2703A Rev. 20100604

Specifications and availability subject to change without notice.

Dealer:

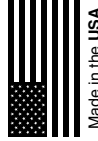

Emerald Condenser Multi-Ton Series

Innovative Chassis Conquers Installation Challenges

NEW!

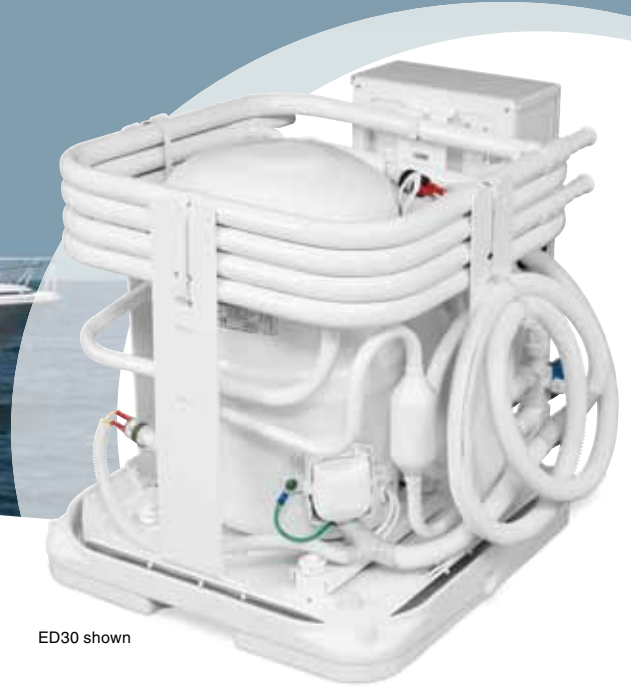

ED30 shown

After listening to boat builders, global service teams and boat owners, Dometic engineers designed a totally innovative Emerald Condenser series to harness and maximize the impressive performance of R-410A refrigerant while meeting all international clean air standards.

The Emerald Condenser has a minimized footprint. This compact design incorporates built-in isolation, two large drain connections and numerous mounting options for installation to a smooth deck, stringer or existing rack. The incorporated lifting handles and smooth bottom allows for easy lifting and quick placement of the unit. The molded composite no-rust drain pan is shaped to provide positive drainage even when the boat heaves and rolls. The amount of standing water in the drain pan is reduced by up to 85%, which is 8x times less than a typical drain pan.

The condensing unit provides quick and easy installation. The drain, seawater and refrigerant connections are conveniently located to conquer installation challenges thus reducing installation time by up to fifteen minutes. The electrical box can be removed and located up to 5 ft. (1.5 m) away, further reducing the size of the unit while making the system more accessible. The reversing valve, pressure switches and service ports are centrally located, high on the unit for access from any side.

Key Benefits

- Up to 85% reduction in condensate drainage.
- Up to 15 minutes faster to install.
- Reduced amps.
- Square chassis for easy installation in tight locations.
- Three mounting options adapt to installation environments.
- Composite drain pan will not rust.
- Built-in refrigerant-line filter drier reduces installation time and protects compressor from moisture and contaminants.
- High-performance engineering maximizes the efficiency of R-410A refrigerant.
- Available in 11 capacities from 6K to 72K BTUs/hr. (For 6K-16K data, please refer to specification sheet L-2703A.)

Technical Specifications for Emerald Condenser Multi-Ton Series

Model ⁽¹⁾	ED24				ED30				ED36				ED48				ED60				ED72										
	230	240	230	460	230	240	230	460	230	240	230	460	230	240	230	460	230	240	230	460	230	240	230	460	230	240	230	460	230	240	230
Capacity (BTU/Hr) ⁽²⁾	30,000																														
Voltage (VAC)	36,000																														
Cycle (Hz)/Phase (Ph) ⁽³⁾	48,000																														
Full Load Amps (FLA) – Cool	64/1814																														
Full Load Amps (FLA) – Heat	70/1984																														
Locked Rotor Amps (Comp)	56/1588																														
K.V.A. (Kilo-Volt-Amps)	Unit Dimensions (in/mm)																														
Max. Circuit Breaker (Amps)	18.0/457																														
Min. Circuit Ampacity (Amps)	16.0/406																														
Refrigerant R-410A (oz/g) ⁽⁴⁾	16.0/406																														
	18.8/478																														
	Connections Ø																														
	3/8"																														
	3/4"																														
	Estimated Weights																														
	120/54.5																														
	135/61.4																														
	150/68.2																														
	165/75.0																														
	155/70.5																														
	170/77.3																														



Notes:
 (1) ED units have a Passport I/O control. For units with a mechanical control, replace the "D" with "M", e.g. "EM24".
 (2) BTU and electrical data are based on a 45°F/7.2°C evaporator and 100°F/37.8°C condenser in cool mode, and a 45°F/7.2°C evaporator and 130°F/54.4°C condenser in heat.
 (3) 60Hz units must not operate at 50Hz and 50Hz units must not operate at 60Hz unless data plate says otherwise.
 (4) Refrigerant charges shown are for R-410A.
 (5) Combined depth of unit and electrical box, as shown in the drawing below. For remote mounting, the electrical box dimensions are 13.25" high X 7.75" wide X 3.75" deep (337 mm X 197 mm X 95 mm).
 * Please refer to spec sheet L-2703A for the Emerald Condenser 6K-16K Series.

DOMETIC MARINE DIVISION
 2000 N. Andrews Ave. Ext. J Pompano Beach, FL 33069 USA | 954-973-2477 | Fax 954-979-4414
 www.DometicUSA.com | MarineSales@DometicUSA.com

24/7 Tech Support for United States & Canada:
 8:00 AM to 5:00 PM Eastern Time: 800-542-2477
 After hours and weekends: 888-440-4494

International Sales & Service:
 Europe & the Middle East: Call +44(0)870-330-6101
 For all other areas visit our website to find your nearest distributor.

Dealer:

Specifications and availability subject to change without notice.

NEW!

TurboVap DX Evaporator Series

Reduced Size, Noise & Amperage

Photo courtesy of Viking Yachts



TV12-230V shown



Marine Air's TurboVap Series of direct expansion (DX) split-system evaporators is based on the revolutionary engineering advancements of the award-winning Turbo self-contained air conditioning system. Featuring a rust-free molded composite drain pan, condensate water is rapidly removed at one of two easy-to-plumb drain locations. The pan also has innovatively designed anti-slosh ridges and "positive flow" channels to ensure condensate does not spill even in the roughest seas.

For improved installation ease and flexibility, the enclosed blower motor eliminates overhang and the blower can be rotated 270° with a single adjustment screw. The unit's unique inlet ring is designed to optimize air flow and ensure that the height of the unit does not increase when the blower rotates. The fully insulated, high-velocity blowers are quiet and efficient.

Experience better noise reduction with the TurboVap Series' built-in cushioning system which minimizes vibration to the deck. Additionally, the innovative mounting clips utilize vibration isolators.

TurboVap units can be paired with condensers that use either R-22 or R-417A refrigerants. See the Emerald Series of TurboVaps and condensers for a complete split system that uses R-410A refrigerant.

Rust-free molded composite drain pan reduces standing water – 2 oz. (59 ml) vs. 16 oz. (473 ml) in ordinary pans. Innovatively engineered "positive flow" drain channels prevent the sloshing and spilling of condensate — even in the roughest seas.



Key Benefits

- Up to 28% reduced amperage.
- Up to 85% reduction of standing water in the drain pan.
- Up to 14% increase in cooling capacity.
- Up to 15% reduced weight.
- Up to 17% reduction in height.
- Up to 19% increased air flow CFM.
- Positive-flow, anti-slosh, rust-free drain pan ensures condensate does not spill.
- Installation time reduced by 15 minutes.
- Single screw for 270° blower rotation.
- No blower-motor overhang reduces depth.
- Vibration-isolation mounting system reduces noise.
- Available in 4K, 6K, 8K, 10K, 12K, and 16K BTU/hr capacities.
- 115V or 230V models.
- Pair with R-22 or R-417A condensing units.

ISO 9001:2008

L-2696A Rev. 20090904

MARINE AIR SYSTEMS®
AIR
 by Dometic GROUP

Technical Specifications for TurboVap DX Evaporators

Model ⁽¹⁾	TV4		TV6		TV8		TV10		TV12		TV16	
Capacity BTU/hr	4,000		6,000		8,000		10,000		12,000		16,000	
Voltage (VAC) @ 50-60Hz/1 Ph	115	230	115	230	115	230	115	230	115	230	115	230
Full Load Amps Blower (FLA)	0.8	0.41	0.8	0.41	1.56	0.83	1.14	0.61	1.14	0.61	1.61	0.78
K.V.A. (Kilo-Volt-Amps)	0.09	0.09	0.09	0.09	0.18	0.19	0.13	0.14	0.13	0.14	0.19	0.18
Suggested Circuit Breaker (Amps)	2.0	1.0	2.0	1.0	4.0	2.0	3.0	1.0	3.0	1.0	4.0	2.0
Unit Dimensions (in/mm)												
Height – Evaporator (H1)	10.8/274		10.8/274		10.8/274		12.6/320		12.6/320		13.0/330	
Height – Blower (H2) ⁽²⁾	10.2/259		10.2/259		11.4/290		12.4/315		12.4/315		13.6/345	
Width	12.3/312		12.3/312		12.3/312		14.3/363		14.3/363		14.3/363	
Depth	9.5/241		9.5/241		9.4/239		10.4/264		10.4/264		11.6/295	
Min. Duct Size Ø	4.0/102		4.0/102		5.0/127		6.0/152		6.0/152		7.0/178	
Min. Supply Air Grille (sq. in./cm.)	32/206		32/206		48/310		60/387		70/452		81/523	
Min. Return Air Grille (sq. in./cm.)	64/413		64/413		80/516		110/710		130/839		160/1032	
Net Weight (lbs./kg.)	10.5/4.8		11.0/5.0		14.0/6.4		17.5/7.9		17.5/7.9		20.5/9.3	
Gross Weight (lbs./kg.)	18.5/8.4		19.0/8.6		22.0/10.0		25.5/11.6		25.5/11.6		28.5/12.9	

Notes:

⁽¹⁾ End all model numbers with a '115V' or '230V' depending on the selected voltage.

⁽²⁾ Add 2.0"/51mm to the height dimension to allow for the duct ring (not included) when the blower is installed in the vertical position.

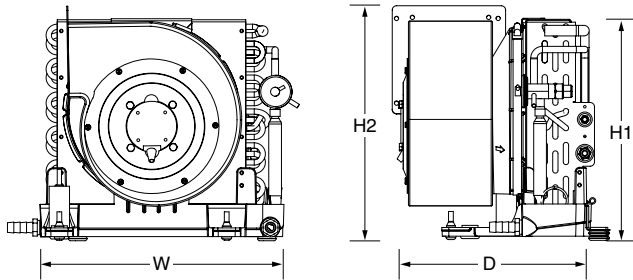

TurboVap 12K unit shown with optional lineset extensions.

Typical Installation of a Split A/C System

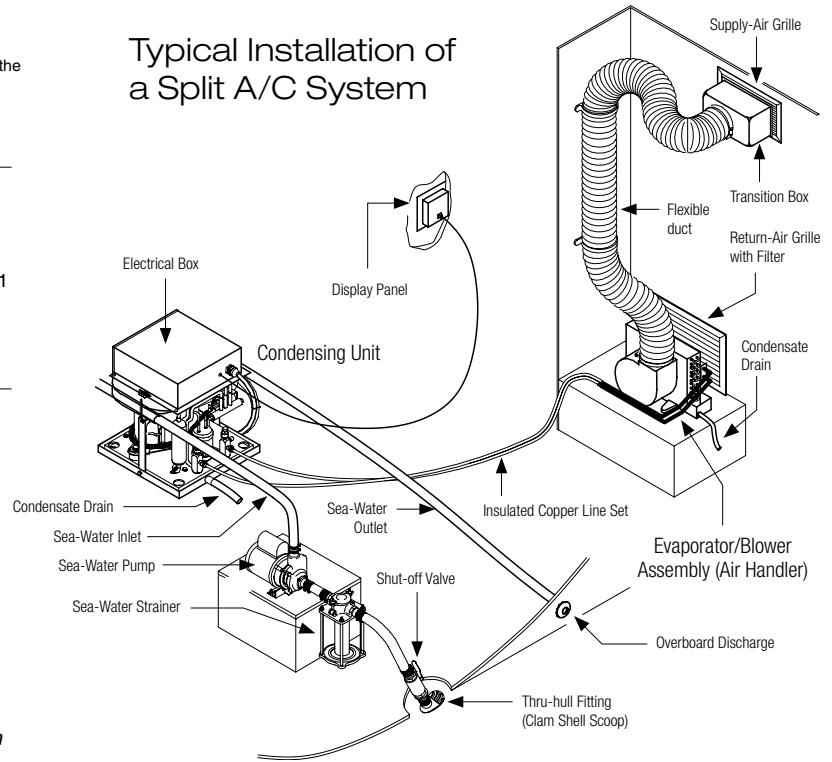

DOMETIC MARINE DIVISION

2000 N. Andrews Ave. Ext. I Pompano Beach, FL 33069 USA | 954-973-2477 | Fax 954-979-4414
www.DometicUSA.com | MarineSales@DometicUSA.com

United States & Canada Tech Support

8:00 AM to 5:00 PM Eastern Time: 800-542-2477
After hours and weekends: 888-440-4494

International Sales & Service:

Europe & the Middle East: Call +44(0)870-330-6101
For all other areas visit our website to find your nearest distributor.



Environmentally Responsible

Dealer:

NEW!

Emerald TurboVap DX Series

Reduced Size, Noise & Amperage



TVE12-230V shown



The Emerald TurboVap series of split-system evaporators incorporates revolutionary design features with mechanical engineering that maximizes the effectiveness of R-410A, an environmentally safe refrigerant.

Emerald TurboVaps are easy to install. For ideal positioning, the high-velocity blower can rotate up to 270 degrees with a single adjustment screw. The enclosed motor means no blower-motor overhang for a compact design.

Since evaporators are usually positioned in or near cabins, noise is always a concern. The Emerald TurboVap uses a vibration-isolation mounting system to minimize noise, so the evaporator runs more quietly. The fully insulated, high-velocity blowers are quiet and efficient.

Excellent condensate drainage is achieved with a unique positive-flow, anti-slosh, composite drain pan that is rust-free. Condensate water is rapidly removed at one of two easy-to-plumb drain locations.

The Emerald TurboVap Series was designed to operate as a system with the Emerald Condenser Series. Both of these split-system components were engineered to harness and maximize the superior thermodynamic properties of the environmentally safe R-410A refrigerant.

The Emerald TurboVap is available in six capacities ranging from 4,000 to 16,000 BTU/hr.

Rust-free molded composite drain pan reduces standing water – 2 oz. (59 ml) vs. 16 oz. (473 ml) in ordinary pans. Innovatively engineered “positive flow” drain channels prevent the sloshing and spilling of condensate — even in the roughest seas.



Key Benefits

- Up to 28% reduced amperage.
- Up to 85% reduction of standing water in the drain pan.
- Up to 14% increase in cooling capacity.
- Up to 15% reduced weight.
- Up to 17% reduction in height.
- Up to 19% increased air flow CFM.
- Positive-flow, anti-slosh, rust-free drain pan ensures condensate does not spill.
- Installation time reduced by 15 minutes.
- Single screw for 270° blower rotation.
- No blower-motor overhang reduces depth.
- Vibration-isolation mounting system reduces noise.
- Pair it with an Emerald Condenser for maximum performance.
- Available in 4K, 6K, 8K, 10K, 12K, and 16K BTU/hr capacities.
- 115V or 230V models.
- Engineered to maximize thermodynamic properties of R-410A, an environmentally safe refrigerant.

Technical Specifications for Emerald TurboVap DX Evaporators

Model ⁽¹⁾	TVE4		TVE6		TVE8		TVE10		TVE12		TVE16	
Capacity BTU/hr	4,000		6,000		8,000		10,000		12,000		16,000	
Voltage (VAC) @ 50-60Hz/1 Ph	115	230	115	230	115	230	115	230	115	230	115	230
Full Load Amps Blower (FLA)	0.8	0.41	0.8	0.41	1.56	0.83	1.14	0.61	1.14	0.61	1.61	0.78
K.V.A. (Kilo-Volt-Amps)	0.09	0.09	0.09	0.09	0.18	0.19	0.13	0.14	0.13	0.14	0.19	0.18
Suggested Circuit Breaker (Amps)	2.0	1.0	2.0	1.0	4.0	2.0	3.0	1.0	3.0	1.0	4.0	2.0
Unit Dimensions (in/mm)												
Height – Evaporator (H1)	10.8/274		10.8/274		10.8/274		12.6/320		12.6/320		13.0/330	
Height – Blower (H2) ⁽²⁾	10.2/259		10.2/259		11.4/290		12.4/315		12.4/315		13.6/345	
Width	12.3/312		12.3/312		12.3/312		14.3/363		14.3/363		14.3/363	
Depth	9.5/241		9.5/241		9.4/239		10.4/264		10.4/264		11.6/295	
Min. Duct Size Ø	4.0/102		4.0/102		5.0/127		6.0/152		6.0/152		7.0/178	
Min. Supply Air Grille (sq. in./cm.)	32/206		32/206		48/310		60/387		70/452		81/523	
Min. Return Air Grille (sq. in./cm.)	64/413		64/413		80/516		110/710		130/839		160/1032	
Net Weight (lbs./kg.)	10.5/4.8		11.0/5.0		14.0/6.4		17.5/7.9		17.5/7.9		20.5/9.3	
Gross Weight (lbs./kg.)	18.5/8.4		19.0/8.6		22.0/10.0		25.5/11.6		25.5/11.6		28.5/12.9	

Notes:

- ⁽¹⁾ End all model numbers with a '115V' or '230V' depending on the selected voltage.
- ⁽²⁾ Add 2.0"/51mm to the height dimension to allow for the duct ring (not included) when the blower is installed in the vertical position.

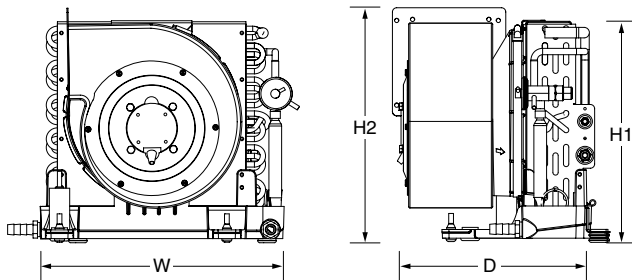

Emerald TurboVap 12K unit shown with optional lineset extensions.

Typical Installation of a Split A/C System

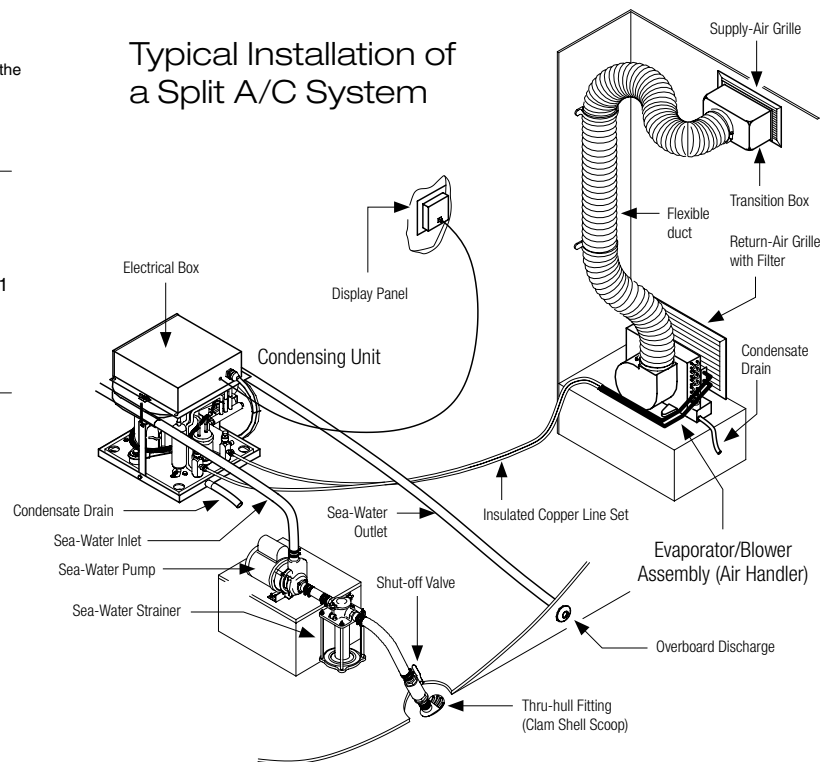

DOMETIC MARINE DIVISION

2000 N. Andrews Ave. Ext. I Pompano Beach, FL 33069 USA | 954-973-2477 | Fax 954-979-4414
www.DometicUSA.com | MarineSales@DometicUSA.com

United States & Canada Tech Support

8:00 AM to 5:00 PM Eastern Time: 800-542-2477
After hours and weekends: 888-440-4494

International Sales & Service:

Europe & the Middle East: Call +44(0)870-330-6101
For all other areas visit our website to find your nearest distributor.



Environmentally Responsible

Dealer:

CS Series Condensing Units

6K to 16K BTU/hr Capacity Range



CSD12K
condensing
unit shown

The CS series of condensing units provide heating and cooling ability in a highly efficient package. The hermetically sealed, high-efficiency compressor reduces amp draw, while pressure switches, thermal-overload and start components provide constant system protection and proper operation. In addition, the expansion device and check-valve assemblies control load balancing during operation. The system's copper-encased cupronickel condenser coils are highly resistant to corrosion that can be caused by continuous seawater flow.

The symmetrical base design provides optimum space efficiency and installation flexibility for easy handling and positioning of the unit. A built-in hose barb aids in complete condensate removal from the drain pan. Two sets of vibration isolators ensure quiet operation.

The electrical box can be mounted remotely. It has a moisture-resistant design with a corrosion-resistant enclosure. CS Digital (CSD) units include the Passport I/O circuit board.

As with all Marine Air products, quality is assured. Each unit is pre-charged, test-run in all operating modes, and leak-checked at the factory prior to shipping. All surface components are constructed of or coated with materials resistant to fire and corrosion. Charge Guard® protection provides sealed access ports that ensure environmental protection and system integrity. All CS condensing units meet or exceed applicable ABYC and US Coast Guard regulations, CE directives, and general Air Conditioning and Refrigeration Industry (ARI) standards.

Key Benefits

- Models available in 6K, 9K, 12K, and 16K BTU/Hr (60Hz and 50Hz).
- High-efficiency system with reduced amp draw.
- Valves and switches provide load balancing and constant system protection.
- Symmetrical base for installation flexibility and ease of handling.
- Remote-mountable, moisture-resistant and corrosion-resistant electrical box.
- Passport I/O circuit board included in electrical box of CSD systems.
- Factory pre-charged, tested, and leak-checked prior to shipping.
- Meets or exceeds all applicable standards and regulations.

Technical Specifications for 6-16K Condensing Units

Model ⁽¹⁾⁽²⁾	CS*6K			CS*9K			CS*12K			CS*16K														
Capacity in BTU/hr	6,000						9,000						12,000						16,000					
Voltage (VAC) ⁽³⁾	115	208-230	220-240	115	208-230	220-240	115	208-230	220-240	115	208-230	220-240	115	208-230	220-240									
Cycle (Hz)/Phase (Ph) ⁽⁴⁾	60/1	60/1	50/1	60/1	60/1	50/1	60/1	60/1	50/1	60/1	60/1	50/1	60/1	60/1	50/1									
R-417A Refrigerant (oz/kg)	22/0.6	22/0.6	22/0.6	N/A	20/0.6	20/0.6	20/0.6	20/0.6	24/0.7	N/A	21/0.6	21/0.6	N/A	21/0.6	21/0.6									
Full Load Amps (FLA) Cool	7.0	3.7	4.1	6.4	3.2	4.6	8.4	4.4	5.4	12.2	5.7	7.0	12.2	5.7	7.0									
Full Load Amps (FLA) Heat	7.7	4.0	4.8	7.2	3.6	5.2	9.2	5.0	6.0	13.5	6.4	8.0	13.5	6.4	8.0									
Locked Rotor Amps (Comp) ⁽⁵⁾	34.0	20.0	21.2	40.0	20.0	25.6	50.0	31.0	31.0	75.0	36.0	39.0	75.0	36.0	39.0									
Kilo-Volt-Amps (KVA) Heat	0.9	0.9	1.2	0.8	0.8	1.2	1.1	1.2	1.4	1.6	1.5	1.9	1.6	1.5	1.9									
Max. Circuit Breaker (Amps)	20	10	10	20	10	15	30	15	15	40	20	25	40	20	25									
Min. Circuit Ampacity (Amps)	13	8	7	13	7	10	17	10	11	25	12	15	25	12	15									
Base Valves (Disch. X Suction)	1/4" X 3/8"			1/4" X 3/8"			1/4" X 3/8"			1/4" X 1/2"														
Height (in/mm) ⁽⁶⁾	15.20/386			15.20/386			15.20/386			15.20/386														
Width (in/mm)	13.13/334			13.13/334			13.13/334			13.13/334														
Depth (in/mm)	13.13/334			13.13/334			13.13/334			13.13/334														
Net Weight (lb/kg) ⁽⁷⁾	56/25.5			64/29.1			66/30.0			66/30.0														
Gross Weight (lb/kg) ⁽⁷⁾	63/28.6			74/33.6			75/34.0			75/34.0														

Notes:
⁽¹⁾ BTU and electrical data are based on a 45°F/7.2°C evaporator and 100°F/37.8°C condenser in cool mode, and a 45°F/7.2°C evaporator and 130°F/54.4°C condenser in heat mode.
⁽²⁾ Add a 'Z' or 'Z50' after the 'K' in the 6K-16K model numbers to denote 208-230V/60Hz or 240-220V/50Hz respectively.
⁽³⁾ Electrical specifications are for reverse cycle units, straight cool units might use smaller circuit breakers.
⁽⁴⁾ Some standard 60Hz units may be operated at 50Hz, at reduced voltages. However, there will be a loss in capacity, and the amp draw may be higher or lower than listed. Dedicated 50Hz units are available that provide full capacity, but these can not be operated at 60Hz. For more information regarding compressor voltages, refer to field notice FN#192-B3 on Dometic Corporation - Environmental Systems' Customer News & Information website.
⁽⁵⁾ Compressor locked rotor amps (LRA) will vary with voltage and load, and may be higher or lower than listed.
⁽⁶⁾ Electrical box height is 2.6"/66mm; subtract that from unit height if box will be remotely mounted.
⁽⁷⁾ Weights are based on 60Hz/1Ph equipment.
 *D = Elite or Passport I/O Control (CSD), M = Mechanical Control (CSM)

Typical Installation of a Split A/C System

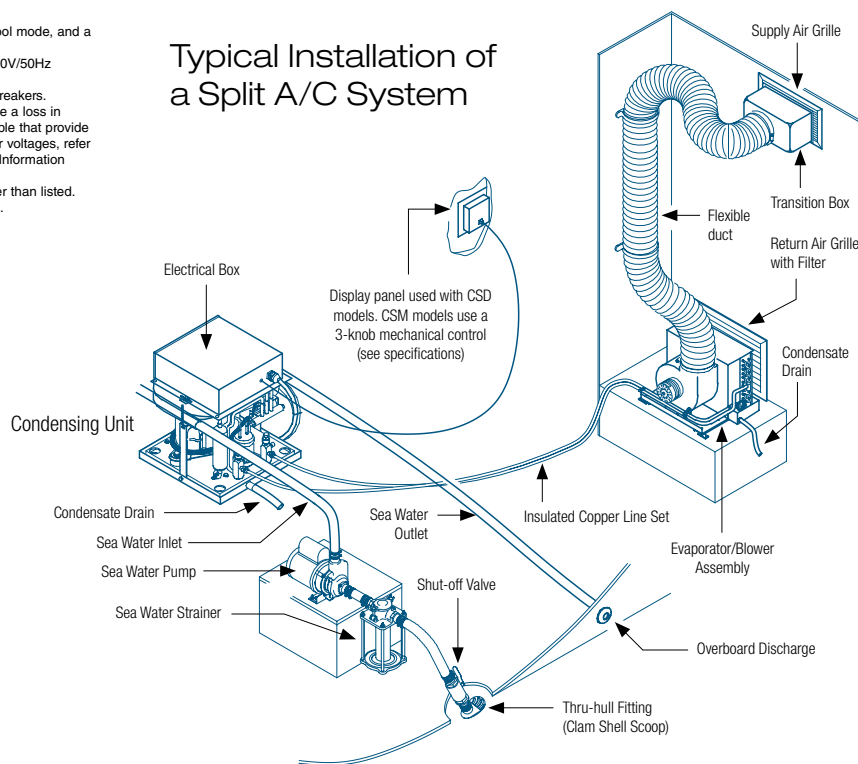

DOMETIC MARINE DIVISION

2000 N. Andrews Ave. Ext. I Pompano Beach, FL 33069 USA | 954-973-2477 | Fax 954-979-4414
 www.DometicUSA.com | MarineSales@DometicUSA.com

United States & Canada Tech Support

8:00 AM to 5:00 PM Eastern Time: 800-542-2477
 After hours and weekends: 888-440-4494

International Sales & Service:

Europe & the Middle East: Call +44(0)870-330-6101
 For all other areas visit our website to find your nearest distributor.



Environmentally Responsible

Dealer:

CS Series Multi-Ton Condensing Units

24K to 60K BTU/hr Capacity Range



CSD36R condensing unit shown



The CS series of multi-ton condensing units provide heating and cooling ability in a highly efficient package. The hermetically sealed, high-efficiency compressor reduces amp draw, while pressure switches, thermal-overload and start components provide constant system protection and proper operation. In addition, the expansion device and check-valve assemblies control load balancing during operation. The system's copper-encased cupronickel condenser coils are highly resistant to corrosion that can be caused by continuous seawater flow.

The symmetrical base design provides optimum space efficiency and installation flexibility for easy handling and positioning of the unit. A built-in hose barb aids in complete condensate removal from the drain pan. Two sets of vibration isolators ensure quiet operation.

The electrical box can be mounted remotely. It has a moisture-resistant design with a corrosion-resistant enclosure. CS Digital (CSD) units include the Passport I/O circuit board.

As with all Marine Air products, quality is assured. Each unit is pre-charged, test-run in all operating modes, and leak-checked at the factory prior to shipping. All surface components are constructed of or coated with materials resistant to fire and corrosion. Charge Guard® protection provides sealed access ports that ensure environmental protection and system integrity. All CS condensing units meet or exceed applicable ABYC and US Coast Guard regulations, CE directives, and general Air Conditioning and Refrigeration Industry (ARI) standards.

Key Benefits

- Models available in 24K, 30K, 36K, 48K, and 60K BTU/Hr (60Hz and 50Hz).
- High-efficiency system with reduced amp draw.
- Valves and switches provide load balancing and constant system protection.
- Symmetrical base for installation flexibility and ease of handling.
- Remote-mountable, moisture-resistant and corrosion-resistant electrical box.
- Passport I/O circuit board included in electrical box of CSD systems.
- Factory pre-charged, tested, and leak-checked prior to shipping.
- Meets or exceeds all applicable standards and regulations

Technical Specifications for Multi-Ton Condensing Units

Model ⁽¹⁾⁽²⁾	CS*24R				CS*30R				CS*36R				CS*48R				CS*60R																					
Capacity in BTU/hr	24,000								30,000								36,000								48,000								60,000					
Voltage (VAC) ⁽³⁾	208-230	208-230	220-240	380-415	208-230	208-230	220-240	220-240	208-230	208-230	220-240	380-415	208-230	208-230	220-240	380-415	208-230	208-230	220-240	380-415	208-230	220-240	440-460															
Cycle (Hz)/Phase (Ph) ⁽⁴⁾	60/1	60/3	50/1	50/3	60/1	60/3	50/1	50/1	60/1	60/3	50/1	50/3	60/1	60/3	50/1	50/3	60/1	60/3	50/1	50/3	60/1	50/1	60/3															
R-417A Refrigerant (oz/kg)	46/1.3	N/A	46/1.3	N/A	50/1.4	N/A	N/A	50/1.4	N/A	N/A	56/1.6	N/A	76/2.2	N/A	76/2.2	N/A	80/2.3	N/A	N/A	80/2.3	N/A	N/A																
Full Load Amps (FLA) Cool	7.3	5.4	7.8	3.1	8.4	6.2	9.8	9.8	10.5	6.9	12.0	4.3	13.1	8.2	22.3	5.4	17.2	22.0	6.1	17.2	22.0	6.1																
Full Load Amps (FLA) Heat	9.0	6.4	9.9	3.7	10.9	7.4	12.1	11.8	12.9	8.3	14.6	5.0	15.9	9.6	24.8	6.3	22.0	24.8	7.4	22.0	24.8	7.4																
Locked Rotor Amps (Comp) ⁽⁵⁾	57.0	48.0	55.0	30.0	66.0	48.0	85.1	65.0	73.0	60.0	87.0	35.0	87.0	70.0	132.2	45.0	132.2	138.0	60.0	132.2	138.0	60.0																
Kilo-Volt-Amps (KVA) Heat	2.1	2.5	2.4	2.7	2.5	2.9	2.9	2.8	3.0	3.3	3.5	3.6	3.7	3.7	6.0	4.5	5.1	6.0	5.9	5.1	6.0	5.9																
Max. Circuit Breaker (Amps)	35	25	35	10	45	30	50	40	50	30	60	15	60	40	80	30	80	80	25	80	80	25																
Min. Circuit Ampacity (Amps)	22	15	22	8	26	17	29	25	29	18	35	11	35	23	46	17	46	50	15	46	50	15																
Base Valves (Disch. X Suct.)	3/8" X 5/8"				3/8" X 3/4"				3/8" X 3/4"				3/8" X 3/4"				5/8" X 3/4"																					
Height (in/mm) ⁽⁶⁾	21.0/546				21.50/546				25.50/648				25.50/648				28.0/732																					
Width (in/mm)	16.00/406				16.00/406				16.00/406				16.00/406				24.00/610																					
Depth (in/mm)	16.00/406				16.00/406				16.00/406				16.00/406				24.00/610																					
Net Weight (lb/kg) ⁽⁷⁾	115/52.2				127/57.6				135/61.2				145/65.8				173/8.5																					
Gross Weight (lb/kg) ⁽⁷⁾	120/54.4				132/59.9				140/63.5				150/68.0				181/81.6																					

- Notes:
- ⁽¹⁾ BTU and electrical data are based on a 45°F/7.2°C evaporator and 100°F/37.8°C condenser in cool mode, and a 45°F/7.2°C evaporator and 130°F/54.4°C condenser in heat mode.
 - ⁽²⁾ Add a 'Z' or 'Z50' after the 'K' in the 24K-60K model numbers to denote 208-230V/60Hz or 240-220V/50Hz respectively.
 - ⁽³⁾ Electrical specifications are for reverse cycle units, straight cool units might use smaller circuit breakers.
 - ⁽⁴⁾ Some standard 60Hz units may be operated at 50Hz, at reduced voltages. However, there will be a loss in capacity, and the amp draw may be higher or lower than listed. Dedicated 50Hz units are available that provide full capacity, but these cannot be operated at 60Hz. For more information regarding compressor voltages, refer to field notice FN#192-B3 on Dometic Corporation - Environmental Systems' Customer News & Information website.
 - ⁽⁵⁾ Compressor locked rotor amps (LRA) will vary with voltage and load, and may be higher or lower than listed.
 - ⁽⁶⁾ Electrical box height is 3.6"/91mm; subtract that from unit height if box will be remotely mounted.
 - ⁽⁷⁾ Weights are based on 60Hz/1Ph equipment.
- *D = Elite or Passport I/O Control (CSD), M = Mechanical Control (CSM)

Typical Installation of a Split A/C System

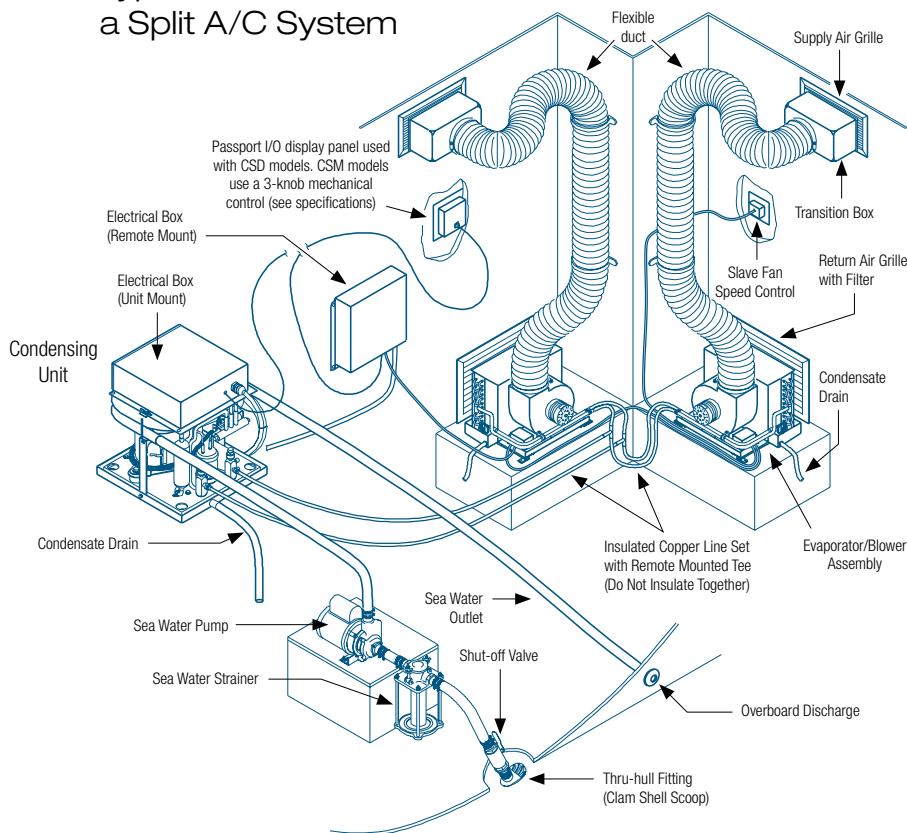

DOMETIC MARINE DIVISION
 2000 N. Andrews Ave. Ext. I Pompano Beach, FL 33069 USA | 954-973-2477 | Fax 954-979-4414
 www.DometicUSA.com | MarineSales@DometicUSA.com

United States & Canada Tech Support
 8:00 AM to 5:00 PM Eastern Time: 800-542-2477
 After hours and weekends: 888-440-4494

International Sales & Service:
 Europe & the Middle East: Call +44(0)870-330-6101
 For all other areas visit our website to find your nearest distributor.



Dealer:

EBE Series R-410A Evaporators

High-Efficiency Units for Split Air Conditioners



EBE18-230V

Marine Air's compact EBE split evaporators are draw-through, ductable cooling units with reverse-cycle heating. Featuring a rotatable, high-efficiency permanent split capacitor (PSC) blower in which the motor is concealed, EBE series evaporators are available in capacities from 6K to 36K BTU/hr. EBHE units have electric heat.

The EBE Series was designed for installation low in a closet, cabinet, or other enclosed space, with discharge air ducted to one or more grilles high in the cabin. EBE units can be used with a combination of plenums and flexible duct, or built-in ductwork may be used. If you are using built-in ductwork, a flexible transition between the blower and duct should be installed.

Vibration-isolation mounting is built into each EBE unit to reduce noise and vibration. The PSC blower is supported by a sturdy aluminum bracket with isolation grommets to reduce possible vibration. The blower's internal motor housing reduces the overall unit depth for easier installation and promotes quieter operation.

The drain pan and blower housing are covered with insulating foam which reduces noise and secondary condensation.

The "positive flow" drain pan has an anti-slosh, antifungal foam lining. Two 1/2 in. (13 mm) drains are located on the blower side of the drain pan.

Marine Air DX evaporators can be controlled using the Elite or Passport I/O keypad displays on the Passport I/O control system.

Key Benefits

- Compact ductable cooling or heating units.
- Rotatable, variable speed blower.
- Insulated condensate pan with anti-slosh, antifungal foam lining.
- High-efficiency blower.
- Environmentally safe R-410A refrigerant.
- Air filter included.
- "Positive Flow" water displacing condensate pan.
- Electric heat available on EBHE models.
- High efficiency evaporator coil.
- Larger blower inlet for increased air flow across coil.
- Blower bracket with vibration isolation grommets installed.
- Increased metal thickness on structural parts for strength.
- Thermal expansion valve for optimal performance over a range of conditions.

Technical Specifications for EBE Series Evaporators

Model	Capacity (BTU/hr)	Voltage (50/60Hz)	Blower Amps	Air Flow (cfm/m ³ h)	Elec. Heat (kW/Amps)	Dimensions (in/mm)				Weight (lb/kg)
						Height 1 ⁽¹⁾	Height 2 ⁽²⁾	Width	Depth	
With Electric Heat										
EBHE6-1kW-230V	6,000	230	0.98	233/395.91	1.0/4.35	11.25/286	12.50/318	13.75/350	12.00/305	14.00/6.35
EBHE8-1kW-230V	8,000	230	0.98	266/451.99	1.0/4.35	11.25/286	12.50/318	13.75/350	12.00/305	14.00/6.35
EBHE10-1.5kW-230V	10,000	230	0.66	333/565.83	1.5/6.52	12.50/318	13.50/343	14.25/362	13.75/349	22.00/9.98
EBHE12-2kW-230V	12,000	230	0.56	400/697.68	2.0/8.70	12.50/318	13.50/343	14.25/362	14.50/368	23.00/10.43
EBHE16-3kW-230V	16,000	230	1.15	533/905.67	3.0/13.04	13.50/343	15.50/394	16.00/406	14.75/375	30.00/13.61
Without Electric Heat										
EBE18-230V	18,000	230	1.13	540/917.47	N/A	13.63/346	15.13/384	16.00/406	14.00/356	32.00/14.51
EBE24-230V	24,000	230	1.62	800/1359.40	N/A	16.50/419	17.00/432	20.00/508	14.50/368	36.00/16.33
EBE30-230V	30,000	230	4.0	1000/1699.20	N/A	20.50/521	22.00/559	20.75/527	15.00/381	43.00/19.50
EBE36-230V	36,000	230	4.0	1200/2039.00	N/A	20.50/521	22.25/565	20.75/527	17.75/451	42.00/19.05

Notes:

⁽¹⁾ Height from base to top of evaporator coil.

⁽²⁾ Height from base to top of blower flange.

Interpreting Model Numbers						
E	B	H	E	X	XkW	230V
Evaporator	High-Efficiency Blower	Electric Heat	R-410A Refrigerant	x1,000 BTU/hr	Kilowatts of Electric Heat	Voltage

Capacity (BTU/hr.)	Minimum Grille Sizes (sq. in/cm)		Minimum Duct (in/mm)
	Return	Discharge	
6,000	64/413	32/206	4/102
8,000	89/574	47/303	5/127
10,000	100/645	60/387	6/152
12,000	130/839	70/452	6/152
16,000	160/1032	80/516	7/178
18,000	200/1290	100/645	8/203
24,000	240/1548	140/903	8/203
30,000	350/2258	170/1097	10/254
36,000	360/2323	196/1265	10/254

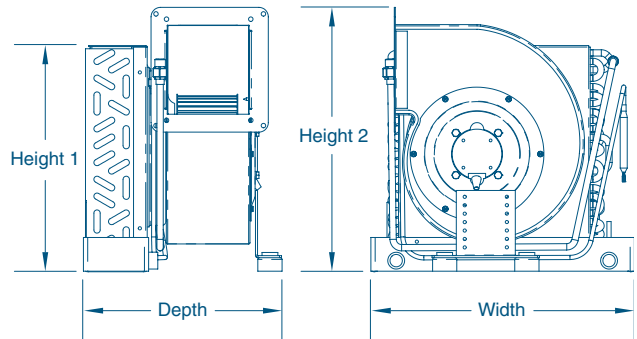

DOMETIC MARINE DIVISION

2000 N. Andrews Ave. Ext. I Pompano Beach, FL 33069 USA | 954-973-2477 | Fax 954-979-4414
 www.DometicUSA.com | MarineSales@DometicUSA.com

24/7 Tech Support for United States & Canada:

8:00 AM to 5:00 PM Eastern Time: 800-542-2477

After hours and weekends: 888-440-4494

International Sales & Service:

Europe & the Middle East: Call +44(0)870-330-6101

For all other areas visit our website to find your nearest distributor.



Environmentally Responsible

Dealer:

EFD Two-Ton Split Evaporator

With High-Efficiency Blower

Photo courtesy of Cruisers Yachts



Marine Air's EFD 24,000 BTU/hr. evaporator features a compact, modular design. For maximum efficiency, the plenum chambers are increased and the coil has enhanced fins and rifled tubing. This unit also offers easy disassembly for access to components for maintenance. It works with Marine Air R-22 or R-417A condensers.

The centrifugal blower is quiet and efficient with a fully-insulated housing. For installation flexibility, the blower rotates to horizontal or vertical positions. The blower's internal motor reduces depth for easier installation. A thermoplastic mounting ring enables easy installation of ducting or transition box.

The condensate drain pan includes two ½ in. (13 mm) FPT drain hook-ups, and it is insulated to prevent sweating.

As with all Marine Air products, quality is assured. Each unit is pre-charged, test-run in all operating modes, and leak-checked at the factory prior to shipping. All surface components are constructed of or coated with materials resistant to fire and corrosion. Charge Guard® protection provides sealed access ports that ensure environmental protection and system integrity. Marine Air evaporators meet or exceed applicable ABYC and US Coast Guard regulations, CE directives, and general Air Conditioning and Refrigeration Industry (ARI) standards.

Key Benefits

- Compact modular design with increased efficiency.
- Easy disassembly for component access.
- Quiet, efficient blower rotates to vertical or horizontal positions.
- Insulated drain pan prevents sweating and includes two ½ in. (13 mm) FPT drain hook-ups.
- Factory pre-charged, tested, and leak-checked prior to shipping.
- Meets or exceeds all applicable standards and regulations.

Technical Specifications for E24FDZ/1

Model	Capacity (BTU/hr.)	Voltage @ 50/60Hz-1Ph	Full Load Amps (FLA)	Max. Circuit Breaker (Amps)	Min. Circuit Ampacity (Amps)	Dimensions (in/mm)			Net Weight (lbs/kg)	Gross Weight (lbs/kg)	
						Height 1	Height 2	Width			Depth
E24FDZ/1	24,000	230	0.80	5	1	16.50/419	N/A	21.25/540	15.60/396	46.0/21.0	54.0/24.5

Notes:

- ⁽¹⁾ Height 1 is measured to top of evaporator or blower discharge, whichever is higher.
- ⁽²⁾ Height 2 is with blower rotated in field.

Capacity (BTU/hr.)	Minimum Grille Sizes (sq. in/cm)		Minimum Duct (in/mm)	Refrigerant Line Sizes (in/mm)	
	Return	Discharge		Discharge	Suction
24,000	240/1548	140/903	8/203	0.38/9.5	0.63/15.9

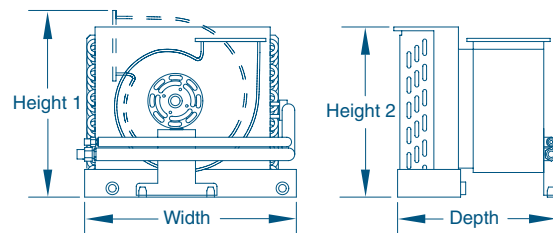

Typical Installation of a Split A/C System

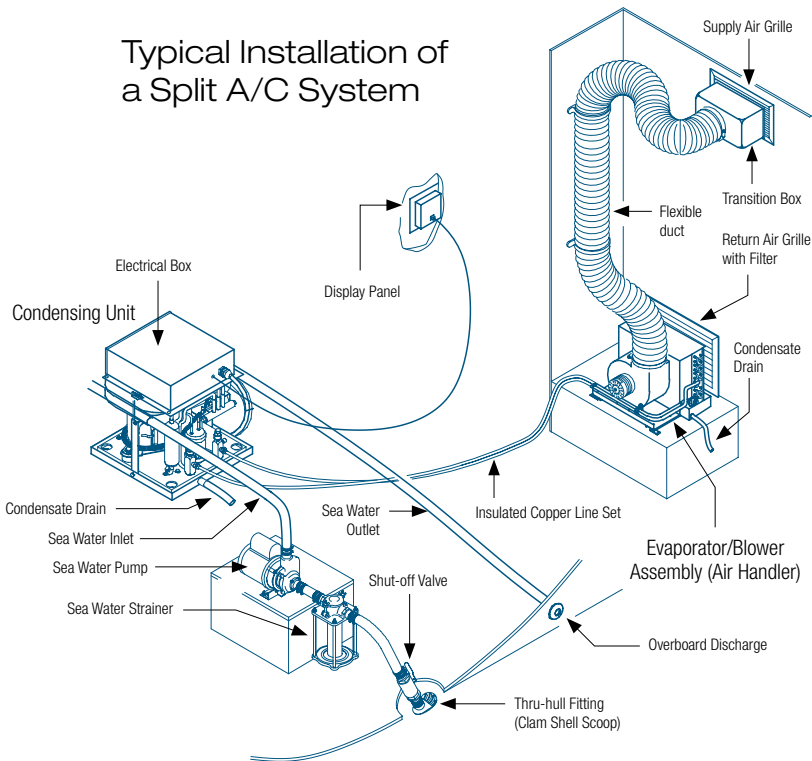

DOMETIC MARINE DIVISION

2000 N. Andrews Ave. Ext. I Pompano Beach, FL 33069 USA | 954-973-2477 | Fax 954-979-4414
 www.DometicUSA.com | MarineSales@DometicUSA.com

24/7 Tech Support for United States & Canada:

8:00 AM to 5:00 PM Eastern Time: 800-542-2477
 After hours and weekends: 888-440-4494

International Sales & Service:

Europe & the Middle East: Call +44(0)870-330-6101
 For all other areas visit our website to find your nearest distributor.



Environmentally Responsible

Dealer:

Chiller Compact

Flexibility In Space, Usage & Layout



CHC16RZ

Marine Air's revolutionary Chiller Compact system is ideal for larger boats in the 45-70' (15-20 m) range. Available in capacities ranging from 16,000 to 24,000 BTU/hr, the Chiller Compact uses circulated water in a closed loop in place of copper refrigerant tubes. The innovative, space-saving compact base of the Chiller Compact was designed to allow individual modules to be multiplexed to provide precise capacity requirements for any application.

Featuring high efficiency components offering maximum performance, the Chiller Compact uses rotary or scroll compressors which are quieter and consume less power. A custom-fabricated condenser coil is constructed of spiral-fluted cupronickel to provide maximum heat transfer and high corrosion resistance.

The environmentally friendly, hermetically-sealed Chiller Compact units use closed-refrigerant circuits, pre-charged with refrigerant. No additional refrigerant is required during the installation or at initial start-up and operation of the system.

Key Benefits

- Compact base design allows flexibility in space, usage and layouts.
- Individual modules can be multiplexed to provide precise capacity requirements for any application.
- Thermodynamically matched components assure maximum performance.
- Rotary and Scroll compressors provide high efficiency performance with less power consumption and quieter operation. The cylindrical shaped compressor allows for a compact design.
- Fewer moving parts ensure higher reliability.
- Condenser coil is custom fabricated of spiral fluted cupronickel to provide maximum heat transfer and high corrosion resistance.
- Exclusive Digital Diagnostic Controller (DDC) with LED display monitors and protects the system through aquastats, high and low pressure switches, timers, freeze controls and high limit switches.
- Each unit is evacuated to below 500 microns, pre-charged, hermetically sealed, load tested and electronically calibrated at the factory.
- Charge Guard® protection provides sealed access ports, ensuring environmental protection and chiller module integrity.
- Meet or exceed applicable ABYC and U.S. Coast Guard regulations, CE Directives and general Air Conditioning and Refrigeration Industry (ARI) standards.

Technical Specifications for Chiller Compact

Model ⁽¹⁾	CHC16RC (Z, Z50)			CHC20RC (Z, Z50)			CHC24SRC (Z, Z50)							
Capacity Cool/RC (BTU/hr)	16,000/17,600			20,000/22,000			24,000/26,400							
Voltage (VAC)	115	230	220	230	220	220	230	220	230	220	380	230	220	380
Cycle (Hz)/Phase (Ph)	60/1	60/1	50/1	60/1	50/1	50/1	60/1	50/1	60/3	50/3	50/3	60/1	50/1	50/3
Full Load Amps (FLA) Cool	8.0	3.8	4.3	5.3	6.1	6.3	6.6	7.5	4.7	4.7	2.7	6.5	7.5	3.1
Full Load Amps (FLA) Heat	11.9	5.6	6.2	7.6	8.4	9.1	8.9	10.4	6.0	7.1	3.5	9.6	10.4	4.1
Locked Rotor Amps (Comp)	67.0	29.0	32.0	45.0	52.0	52.0	54.0	56.0	45.0	56.0	26.0	56.0	56.0	32.0
Kilo-Volt-Amps (KVA)	1.4	1.3	10.4	1.7	1.8	2.0	2.0	2.3	2.4	2.7	2.3	2.2	2.3	2.7
Max. Circuit Breaker (Amps)	35.0	20.0	20.0	25.0	30.0	30.0	35.0	40.0	20.0	25.0	10.0	35.0	40.0	15.0
Min. Circuit Ampacity (Amps)	22.0	12.0	13.0	17.0	17.0	17.0	20.0	23.0	14.0	15.0	8.0	20.0	25.0	9.0
R-407C Refrigerant (oz/g)	10/283			N/A	12/340		N/A	N/A	N/A			13/367	18/510	
Net Weight 60Hz [50 Hz] (lb/kg)	52/23.6 [58/26.3]			65/29.5 [84/38.1]			84/38.1 [101/45.8]							
Gross Weight 60Hz [50 Hz] (lb/kg)	62/28.1 [68/30.8]			75/34.0 [94/42.6]			94/42.6 [111/50.3]							
Dimensions ⁽²⁾	All CHC16 Units			60Hz CHC20 ⁽³⁾			50Hz CHC20 & All CHC24							
Height (in/mm)	12.75/324			13.50/343			15.75/400							
Width (in/mm)	11.50/292			11.50/292			13.00/330							
Depth (in/mm)	18.00/457			18.00/457			18.00/457							

Advantages of a Marine Air Chiller System

- No refrigeration line sets and mechanical flare fittings which are subject to leaking refrigerant over time.
- Environmentally friendly hermetically sealed modules.
- No EPA certified technician required for startup or field installation.
- Flexible hose is easier to install and insulate compared to refrigerant line sets.
- Provide full cooling capacity to areas which require fast pull downs from hot starts.
- Most applications result in fewer compressors, which increases reliability, reduces weight and conserves power.

CHC Pump Packages ⁽¹⁾	PMA1000	P120	P700
Voltage (VAC)	115/230	115/230	115/230
Amps (60Hz/1Ph)	2.1/1.0	4.9/3.5	7.2/3.6
Net Weight (lb/kg)	24/10.9	39/17.7	40/18.1
Gross Weight (lb/kg)	30/13.6	45/20.4	46/20.9
Height (in/mm)	9.0/229 ⁽⁴⁾	7.5/191	8.0/203
Width (in/mm)	13.0/330	13.0/330	13.0/330
Depth (in/mm)	18.0/457	18.0/457	18.0/457

Notes:
⁽¹⁾ Model numbers: CHC = Chiller Compact; 16, 20, 24 = BTU/H x 1000; RC = Reverse Cycle; Z = 230/60; Z50 = 220/50; 3 = 3 Phase; S = Scroll compressor (Rotary compressors are used on the 16 & 60Hz 20).
⁽²⁾ Add 1.0"/25mm for mounting brackets. Brackets can be mounted on any side of base pan (depth or width).
⁽³⁾ The 50Hz CHC20s have the same dimensions as the CHC24s.
⁽⁴⁾ The PMA1000 Pump Package is 9.0"/229mm tall at the water outlet and 7.5"/191mm tall at the pump.

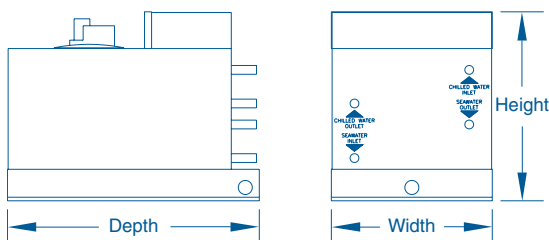

Typical Installation of a Chiller Compact System

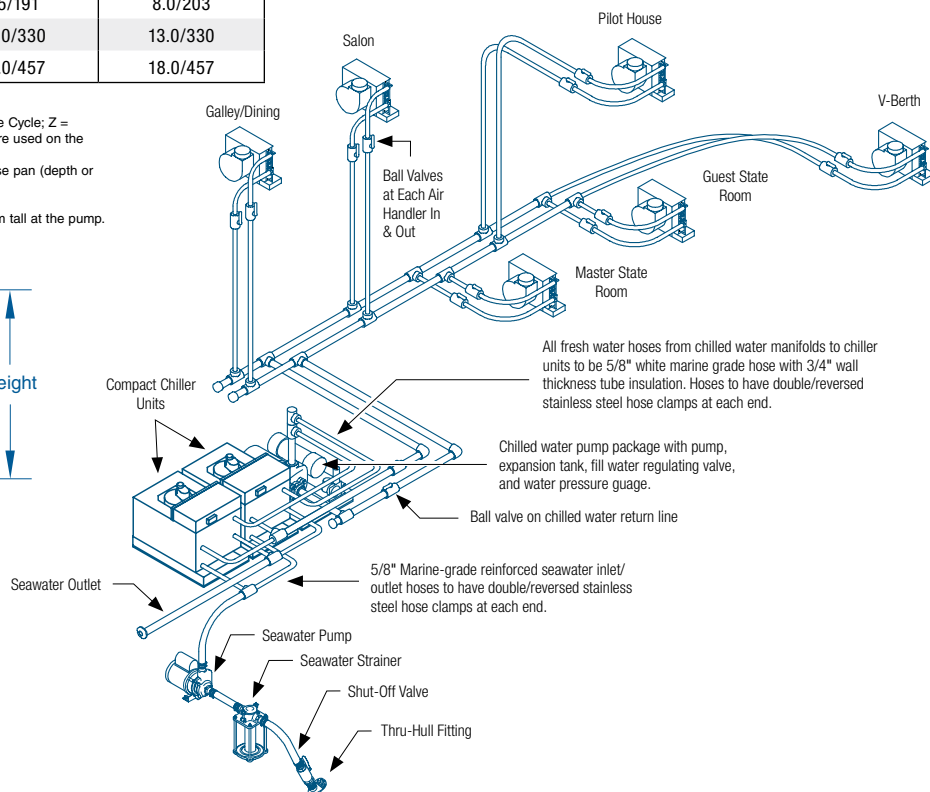

All fresh water hoses from chilled water manifolds to chiller units to be 5/8" white marine grade hose with 3/4" wall thickness tube insulation. Hoses to have double/reversed stainless steel hose clamps at each end.

Chilled water pump package with pump, expansion tank, fill water regulating valve, and water pressure gauge.

Ball valve on chilled water return line

5/8" Marine-grade reinforced seawater inlet/outlet hoses to have double/reversed stainless steel hose clamps at each end.

DOMETIC MARINE DIVISION

2000 N. Andrews Ave. Ext. I Pompano Beach, FL 33069 USA | 954-973-2477 | Fax 954-979-4414
 www.DometicUSA.com | MarineSales@DometicUSA.com

United States & Canada Tech Support

8:00 AM to 5:00 PM Eastern Time: 800-542-2477
 After hours and weekends: 888-440-4494

International Sales & Service:

Europe & the Middle East: Call +44(0)870-330-6101
 For all other areas visit our website to find your nearest distributor.



Environmentally Responsible

Dealer:

MCG Low-Profile R-410A Chillers

Space-Saving Chiller Design

12.5- & 15-Ton
Models Available!



MCG-LP 5-ton
chiller shown

Marine Air MCG Low-Profile Chillers are designed for locations onboard where height is an obstacle. At 18.25"/464 mm (3 to 6 ton) and 25.2"/640 mm (12.5 and 15 ton) tall, MCG-LP modules are much shorter than other chillers in the same capacity range, but no shorter on high performance and reliability.

MCG-LP modules provide reverse-cycle cooling and heating and are available in capacities from 36,000 to 180,000 BTU/hr (3 to 15 tons). Individual modules can be staged for larger capacities. The R-410A environmentally safe refrigerant has exceptional thermodynamic properties and maximizes system efficiency.

Performance and reliability is further improved with up to 25 percent more condenser area than similar low-profile units, and an expansion valve that modulates the refrigerant.

MCG-LP chillers are monitored and protected by Marine Air's exclusive Digital Diagnostic Controller (DDC), which can be installed remotely. For staged systems, the Chilled Water Master Controller (CWMC) provides central control over each DDC on each module in the system. Up to six modules are supported. The CWMC coordinates all cooling and heating functions, evenly distributes compressor run times, and operates the seawater and circulated water pumps.

The MCG-LP series has stainless-steel drain pans for 3 to 6 ton modules, and lightweight painted aluminum for 12.5 to 15 ton modules. All models have removable PVC water headers that resist corrosion and erosion.

Key Benefits

- Fits into height-restrictive spaces.
- Reverse cycle standard.
- Stainless-steel drain pan (3–6 ton only).
- Lightweight painted aluminum drain pan (12.5–15 ton only).
- 3 to 15 ton capacities.
- Modules can be staged for larger capacities.
- Up to 25% more condenser area than similar units.
- Environmentally safe R-410A refrigerant.
- Electrical box remotely mounted up to 6' (1.8 m) away.
- Removable PVC water headers resist corrosion and erosion.
- Expansion valve modulates refrigerant for improved performance.
- Hot-gas bypass to provide heating in cold seawater conditions (3–6 ton only).

Technical Specifications for MCG Low-Profile Chilled Water Series

Model (Capacity)	Volt/Hz/Ph ⁽¹⁾	FLA Cool	FLA Heat	LRA	MCG-LP Single Module Dimensions (in/mm) ⁽²⁾					SW Ø (in/mm)	CW Ø (in/mm)	Weight ⁽³⁾ (lbs/kg)	Mounted DDC Dimensions (in/mm) ⁽²⁾		
					H	W1	W2	D1	D2				Height	Width	Depth
MCG-LP 3 Ton (36,000 BTU/hr)	208-240/60/1	10.9	15.6	112.0	18.25/464	12.00/305	12.69/322	24.00/610	25.38/645	1.00/25	1.00/25	160/73	11.00/279	9.80/249	3.70/94
	220-240/50/1	11.6	16.9	97.0											
	208-230/60/3	7.3	9.4	88.0											
MCG-LP 4 Ton (48,000 BTU/hr)	208-240/60/1	13.0	19.1	135.0	18.25/464	12.00/305	12.69/322	24.00/610	25.38/645	1.00/25	1.00/25	160/73	11.00/279	9.80/249	3.70/94
	220-240/50/1	14.4	20.7	136.0											
	208-230/60/3	9.1	12.2	98.0											
	440-480/60/3	4.7	6.2	46.0											
MCG-LP 5 Ton (60,000 BTU/hr)	208-240/60/1	17.0	24.7	158.0	18.25/464	12.00/305	12.69/322	24.00/610	25.38/645	1.00/25	1.25/32	174/79	11.00/279	9.80/249	3.70/94
	220-240/50/1	21.5	30.1	176.0											
	208-230/60/3	10.6	14.4	110.0											
	440-480/60/3	6.2	8.2	75.0											
MCG-LP 6 Ton (72,000 BTU/hr)	208-240/60/1	23.3	32.5	148.0	18.25/464	12.00/305	12.69/322	24.00/610	25.38/645	1.00/25	1.25/32	174/79	11.00/279	9.80/249	3.70/94
	208-230/60/3	14.2	18.2	149.0											
	440-480/60/3	6.9	9.1	75.0											
	380-420/50/3	9.0	11.7	101.0											
MCG-LP 12.5 Ton (150,000 BTU/hr)	208-230/60/3	29.5	38.0	245	25.20/640	20.13/511	21.50/546	36.75/933	40.03/1,017	2.00/51	2.00/51	335/152	13.30/338	12.00/305	4.30/109
	440-480/60/3	13.8	18.0	125											
	380-420/50/3	21.2	26.2	173											
MCG-LP 15 Ton (180,000 BTU/hr)	208-230/60/3	41.9	52.0	340.0	25.20/640	20.13/511	21.50/546	36.75/933	40.03/1,017	2.00/51	2.00/51	365/166	13.30/338	12.00/305	4.30/109
	440-480/60/3	21.2	26.2	173.0											
	380-420/50/3	25.5	31.7	196.0											

Notes:
⁽¹⁾ For more information regarding compressor voltages, please refer to field notice FNR#192-B3-M.
⁽²⁾ All dimensions ± 1/4" (6 mm).
⁽³⁾ All weights ± 10%.

MCG-LP 3- to 6-Ton Module Dimensions

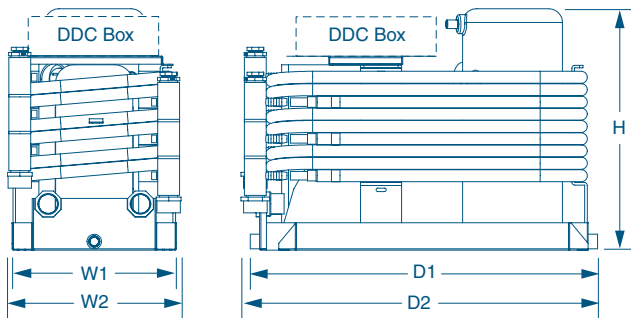

MCG-LP 12.5- to 15-Ton Module Dimensions

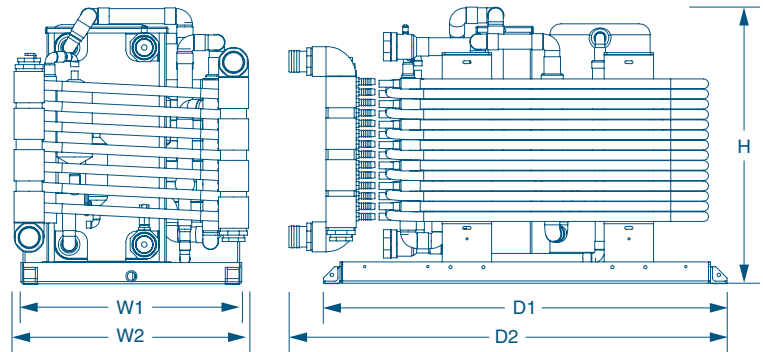

DOMETIC MARINE DIVISION

2000 N. Andrews Ave. Ext. I Pompano Beach, FL 33069 USA | 954-973-2477 | Fax 954-979-4414
 www.DometicUSA.com | MarineSales@DometicUSA.com

24/7 Tech Support for United States & Canada:

8:00 AM to 5:00 PM Eastern Time: 800-542-2477
 After hours and weekends: 888-440-4494

International Sales & Service:

Europe & the Middle East: Call +44(0)870-330-6101
 For all other areas visit our website to find your nearest distributor.



Environmentally Responsible

Dealer:

MCG Chiller Series

Modular Chilled Water Air Conditioning

Now Available
With R-410A



MCG 5-Ton shown

Marine Air's MCG chilled water series is available in capacities ranging from 24,000 (2 ton) to 180,000 (15 ton) BTU/hr. Featuring a compact base design, MCG modules can be staged to provide a larger system, which is easily retrofitted and serviced in the field. Up to six 15-ton stages can be configured for a system total of 1,080,000 BTU/hr., or 90 tons.

Each refrigerant circuit is hermetically sealed and factory pre-charged with R-410A refrigerant. This environmentally safe refrigerant has exceptional thermodynamic properties and maximizes system efficiency.

Each condensing unit is monitored and protected with freeze controls, high-limit switches, high and low aquastats, and timers. These condensing units can be installed in any convenient location and are unaffected by vibration, moisture or ambient temperatures up to 140°F/60°C.

MCG chillers are monitored and protected by Marine Air's exclusive Digital Diagnostic Controller (DDC), which can be installed remotely. For staged systems, the Chilled Water Master Controller (CWMC) provides central control over each DDC on each module in the system. Up to six modules are supported. The CWMC coordinates all cooling and heating functions, evenly distributes compressor run times, and operates the seawater and circulated water pumps.

MCGs are available in single phase or three phase, 50Hz or 60Hz, and all standard voltages (208, 230, 380, 460 VAC).

Key Benefits

- Small footprint allows installation flexibility.
- Corrosion-resistant, durable, lightweight aluminum construction.
- Can be multiplexed in custom configurations for large capacities.
- Remote-mountable electrical box allows easy access for adjustments or service.
- Bi-flow expansion valves balance systems between heat and cool modes.
- Compact stainless-steel brazed plate heat exchangers for maximum efficiency.
- Spiral-fluted cupronickel condenser coil provides maximum heat transfer.
- Exclusive Digital Diagnostic Controller (DDC) monitors and protects the system.
- Environmentally safe R-410A refrigerant.
- Charge Guard® protection provides sealed access ports, ensuring environmental protection and system integrity.
- All units meet or exceed applicable ABYC and U.S. Coast Guard regulations, CE Directives and general Air Conditioning and Refrigeration Industry (ARI) standards.

Technical Specifications for MCG Modular Chilled Water Series

Model (Capacity)	Volts/Hz/Ph ⁽¹⁾	FLA Cool	FLA Heat	LRA	MCG Single Module Dimensions (in/mm) ⁽²⁾						SW Ø	CW Ø	Weight (lb/kg) ⁽³⁾	Mounted DDC Dimensions (in/mm) ⁽²⁾		
					H1	H2	W1	W2	D1	D2				Height	Width	Depth
MCG 24 (24,000 BTU/hr)	208-240/60/1	6.4	9.5	58.3	17.22/ 437	21.74/ 552	12.00/ 305	12.00/ 305	24.00/ 610	24.97/ 634	1.00"	1.00"	194/88	11.00/ 279	9.80/ 249	3.70/ 94
	220-240/50/1	7.5	11.0	67.0												
	208-230/60/3	5.5	7.3	58.0												
	440-480/60/3	2.7	3.6	28.0												
MCG 36 (36,000 BTU/hr)	208-240/60/1	10.9	15.6	112.0	23.57/ 599	23.57/ 599	12.00/ 610	12.50/ 318	24.00/ 610	30.78/ 782	1.00"	1.00"	194/88	11.00/ 279	9.80/ 249	3.70/ 94
	220-240/50/1	11.6	16.9	97.0												
	208-230/60/3	7.3	9.4	88.0												
	440-480/60/3	4.0	5.2	44.0												
MCG 48 (48,000 BTU/hr)	208-240/60/1	13.0	19.1	135.0	23.57/ 599	23.57/ 599	12.00/ 610	12.50/ 318	24.00/ 610	30.84/ 783	1.00"	1.00"	241/109	11.00/ 279	9.80/ 249	3.70/ 94
	220-240/50/1	14.4	20.7	136.0												
	208-230/60/3	9.1	12.2	98.0												
	440-480/60/3	4.7	6.2	46.0												
MCG 60 (60,000 BTU/hr)	208-240/60/1	17.0	24.7	158.0	23.44/ 595	26.08/ 662	12.00/ 610	13.25/ 337	24.00/ 610	30.07/ 764	1.00"	1.25"	263/119	11.00/ 279	9.80/ 249	3.70/ 94
	220-240/50/1	21.5	30.1	176.0												
	208-230/60/3	10.6	14.4	110.0												
	440-480/60/3	6.2	8.2	75.0												
MCG 72 (72,000 BTU/hr)	208-240/60/1	23.3	32.5	148.0	23.44/ 595	26.08/ 662	12.00/ 610	13.25/ 337	24.00/ 610	30.04/ 763	1.00"	1.25"	267/121	11.00/ 279	9.80/ 249	3.70/ 94
	208-230/60/3	14.2	18.2	149.0												
	440-480/60/3	6.9	9.1	75.0												
	380-420/50/3	9.0	11.7	101.0												
MCG 90 (90,000 BTU/hr)	208-230/60/3	19.5	24.9	195.0	27.66/ 703	31.07/ 789	16.00/ 406	17.37/ 441	24.00/ 610	30.84/ 783	1.50"	1.50"	410/186	13.30/ 338	12.00/ 305	4.30/ 109
	440-480/60/3	9.8	12.4	95.0												
	380-420/50/3	10.8	13.6	111.0												
MCG 120 (120,000 BTU/hr)	208-230/60/3	25.3	32.8	239.0	33.61/ 854	37.71/ 958	16.00/ 406	17.40/ 442	24.00/ 610	30.84/ 783	1.50"	1.50"	500/227	13.30/ 338	12.00/ 305	4.30/ 109
	440-480/60/3	12.7	16.4	125.0												
	380-420/50/3	13.3	17.8	118.0												
MCG 150 (150,000 BTU/hr)	208-230/60/3	29.5	38.0	245	46.24/ 1174	N/A	18.63/ 473	19.50/ 495	26.75/ 679	31.88/ 810	2.00"	2.00"	545/247	N/A		
	440-480/60/3	13.8	18.0	125												
	380-420/50/3	21.2	26.2	173												
MCG 180 (180,000 BTU/hr)	208-230/60/3	41.9	52.0	340.0	49.20/ 1250	N/A	18.63/ 473	19.50/ 495	26.75/ 679	31.88/ 810	2.00"	2.00"	600/272	N/A		
	440-480/60/3	21.2	26.2	173.0												
	380-420/50/3	25.5	31.7	196.0												

Dimensions (in/mm) for Multi-Stage Chillers⁽²⁾

No. of Stages	Base Dimensions (in/mm)			CWMC with DDC Dimensions (in/mm)		
	Height ⁽⁵⁾	Width ⁽⁶⁾	Depth ⁽⁶⁾	Height	Width	Depth
2- to 6-Ton Modules						
2 Stages	1.50/38	28.00/711	31.00/787	24.00/610	22.00/559	7.75/199
3 Stages ⁽⁷⁾	1.50/38	41.50/1054	31.00/787	24.00/610	22.00/559	7.75/199
4 Stages	1.50/38	55.50/1410	31.00/787	24.00/610	30.00/762	7.75/199
5 Stages	1.50/38	69.50/1765	31.00/787	24.00/610	35.00/889	7.75/199
7.5- to 10-Ton Modules						
2 Stages	3.00/76	36.00/914	35.50/902	24.00/610	22.00/559	7.75/199
3 Stages ⁽⁷⁾	3.00/76	53.50/1359	35.50/902	24.00/610	22.00/559	7.75/199
4 Stages	3.00/76	72.50/1816	35.50/902	24.00/610	30.00/762	7.75/199
5 Stages	3.00/76	88.50/2248	35.50/902	24.00/610	35.00/889	7.75/199
12.5- to 15-Ton Modules						
2 Stages	3.00/76	39.25/997	38.75/984	24.00/610	22.00/559	7.75/199
3 Stages ⁽⁷⁾	3.00/76	59.88/1521	38.75/984	24.00/610	22.00/559	7.75/199
4 Stages	3.00/76	80.50/2045	38.75/984	24.00/610	30.00/762	7.75/199
5 Stages	4.00/102	101.13/3569	38.75/984	24.00/610	35.00/889	7.75/199

Notes:

⁽¹⁾ For more information regarding compressor voltages, please refer to field notice FNR#192-B3-M.
⁽²⁾ All dimensions ± 1/4" (6 mm). ⁽³⁾ All weights ± 10%. ⁽⁴⁾ Add 1.00" (25 mm) for mounting tabs and minimum clearance on bottom of 4.00" (102 mm) for harness. ⁽⁵⁾ Add single module height and base height for overall height. ⁽⁶⁾ Manifolds may extend up to 5.00" (127 mm) in front of and up to 7.00" (178 mm) to the side of base. ⁽⁷⁾ Use 4-stage size for electric heat and 3-4 pumps.

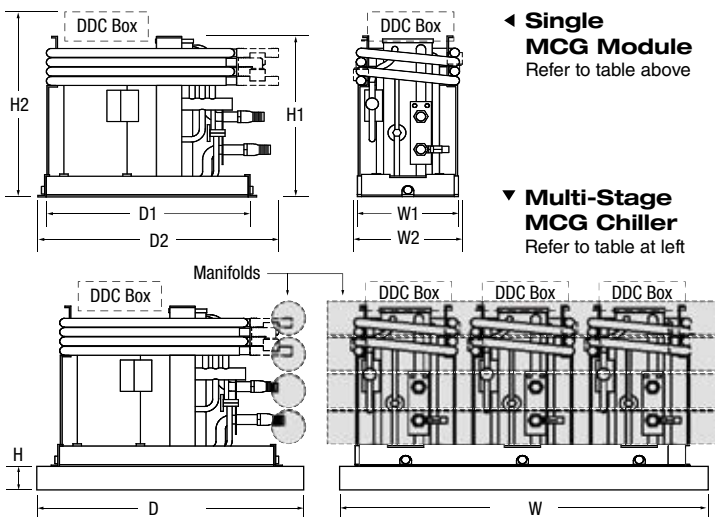

◀ **Single MCG Module**
Refer to table above

▼ **Multi-Stage MCG Chiller**
Refer to table at left

DOMETIC MARINE DIVISION

2000 N. Andrews Ave. Ext. I Pompano Beach, FL 33069 USA | 954-973-2477 | Fax 954-979-4414
 www.DometicUSA.com | MarineSales@DometicUSA.com

24/7 Tech Support for United States & Canada:

8:00 AM to 5:00 PM Eastern Time: 800-542-2477
 After hours and weekends: 888-440-4494

International Sales & Service:

Europe & the Middle East: Call +44(0)870-330-6101
 For all other areas visit our website to find your nearest distributor.



Environmentally Responsible

Dealer:

Staged Chilled Water

Up to Six Stages for Maximum Capacity



SCW 24-Ton

Staged Chilled Water (SCW) chillers are available in capacities ranging from 48,000 (4 ton) to 1,080,000 (90 ton) BTU/hr. SCWs are available in single phase or three phase, 50Hz or 60Hz, and all standard voltages (208, 230, 380, 460 VAC). Multiple compressors and refrigerant circuits are incorporated to provide minimal power consumption versus load demands, as well as redundancy throughout the unit. Each condensing unit is monitored and protected with freeze controls, high limit switches, high and low aquastats, timers and on-board fuses or breakers.

All access ports to the refrigerant system are protected with Charge Guard®, a factory installed seal, ensuring system integrity from shipping through final installation.

Condenser coils are constructed with cupro-nickel to provide high corrosion resistance. Unique stainless steel evaporator plates are designed for maximum efficiency of heat transfer. SCWs can be built with circulation pump mounted in the chiller frame. Frames are welded with marine grade aluminum alloy, primed, then finished with a corrosion resistant epoxy.

These condensing units can be installed in any convenient location and are highly resistant to vibration, moisture or ambient temperatures up to 140°F/60°C. Units meet or exceed Coast Guard regulations.

Key Benefits

- Cupronickel condenser coils and copper refrigerant shells for maximum efficiency and corrosion resistance.
- Copper-brazed, stainless-steel plate exchangers for maximum efficiency.
- Computer matched components provide maximum cooling/heating capacity.
- Thermal expansion valves automatically adjust to changing load requirements.
- Individual stages are protected by a circuit breaker, flow switch, freeze protection, water temperature high limit, high pressure refrigerant switch, and low pressure refrigerant switch.
- Compact base design provides flexibility in engine room layouts.
- Lightweight aluminum frame construction.
- Complete control circuit provides multiple fail safes for system protection.
- Vertically mounted units are available.
- Redundant design assures cooling if one circuit malfunctions.
- All compressors accessed from front of condensing unit ensuring easy change out.

Electrical Specifications for Individual R-410A Stages

Capacity	24,000 BTU/hr.	36,000 BTU/hr.	48,000 BTU/hr	60,000 BTU/hr	72,000 BTU/hr	90,000 BTU/hr	120,000 BTU/hr	150,000 BTU/hr	180,000 BTU/hr
Volts/Hz/Ph ⁽¹⁾	208-240/60/1 220-240/50/1 208-230/60/3 440-480/60/3	208-240/60/1 220-240/50/1 208-230/60/3 440-480/60/3	208-240/60/1 220-240/50/1 208-230/60/3 440-480/60/3 380-420/50/3	208-240/60/1 220-240/50/1 208-230/60/3 440-480/60/3 380-420/50/3	208-240/60/1 220-240/50/1 208-230/60/3 440-480/60/3 380-420/50/3	208-230/60/3 440-480/60/3 380-420/50/3	208-230/60/3 440-480/60/3 380-420/50/3	208-230/60/3 440-480/60/3 380-420/50/3	208-230/60/3 440-480/60/3 380-420/50/3
FLA Cool	6.4 7.5 5.5 2.7	10.9 11.6 7.3 4.0	13.0 14.4 9.1 4.7 4.9	17.0 21.5 10.6 6.2 6.8	23.3 14.2 6.9 9.0	19.5 9.8 10.8	25.3 12.7 13.3	29.5 13.8 21.2	41.9 21.2 25.5
FLA Heat	10.9 11.6 7.3 4.0	15.6 16.9 9.4 5.2	19.1 20.7 12.2 6.2 7.0	24.7 30.1 14.4 8.2 9.1	32.5 18.2 9.1 11.7	24.9 12.4 13.6	32.8 16.4 17.8	38.0 18.0 26.2	52.0 26.2 31.7
LRA	58.3 67.0 58.0 28.0	112.0 97.0 88.0 44.0	135.0 136.0 98.0 46.0 51.5	158.0 176.0 110.0 75.0 74.0	148.0 149.0 75.0 101.0	195.0 95.0 111.0	239.0 125.0 118.0	245 125 173	340.0 173.0 196.0

Notes:

⁽¹⁾ For more information regarding compressor voltages, please refer to field notice FNR#192-B3-M.

• Due to the number of variables, physical dimensions and weights for SCW Systems are not listed here. Please contact Dometic at 954-973-2477 to discuss your system with a sales representative.

Heating

Heating capabilities can be provided through a variety of choices, depending upon requirements. Reverse-cycle provides the most efficient heating (four times more efficient than electric heating), but requires a seawater temperature ≥ 40°F (5°C). Electric heating provides adequate capacities for vessels operating in all waters, but is limited by the power (amperage) available for operation. Auxiliary heating is available through the use of electric heating elements installed in the air handlers. Each of these elements provides 1-3 kW of heat that can be operated independently or in combination with the central heating circuit to maintain temperatures inside the vessel.

Recommended Heater kW & Stages for Electric Heat (EH) Chillers

Tons Per Stage	2 Stage	3 Stage	4 Stage	5 Stage
2	6kW/1 Stage	6kW/1 Stage	12kW/2 Stage	12kW/2 Stage
3	6kW/1 Stage	10kW/1 Stage	12kW/2 Stage	18kW/3 Stage
4	10kW/1 Stage	12kW/2 Stage	18kW/3 Stage	20kW/2 Stage
5	12kW/2 Stage	18kW/3 Stage	24kW/ 4 Stage	18kW/3 Stage
6	12kW/2 Stage	18kW/3 Stage	24kW/4 Stage	30kW/3 Stage
7.5	20kW/2 Stage	26kW/2 Stage	30kW/3 Stage	40kW/4 Stage
10	20kW/2 Stage	30kW/3 Stage	40kW/4 Stage	52kW/4 Stage
12.5	26kW/2 Stage	39kW/3 Stage	45kW/3 Stage	60kW/4 Stage
15	30kW/2 Stage	45kW/3 Stage	60kW/4 Stage	80kW/4 Stage

Electric Box

The drip-proof electric box is available with custom harness lengths to fit each application.

- A** Chilled Water Master Controller (CWMC) Display.
- B** CWMC circuit board.
- C** Digital Diagnostic Controller (DDC). Please reference the Chilled Water Master Controller specifications sheet for more details.
- D** Data plates and wiring diagram.

All compressors, pumps, and heaters are protected by individual circuit breakers **E**, controlled by contactors **F**, and three-phase pumps **G** are also protected by overloads.

- H** All wiring from the electric box to the chiller components is connected via feed through terminals for easy troubleshooting.

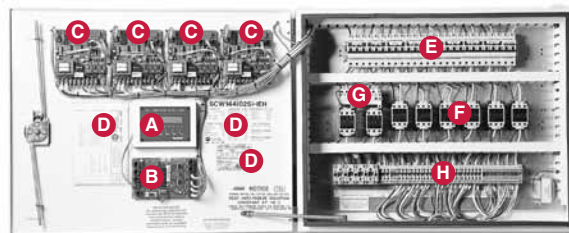

DOMETIC MARINE DIVISION

2000 N. Andrews Ave. Ext. I Pompano Beach, FL 33069 USA | 954-973-2477 | Fax 954-979-4414
www.DometicUSA.com | MarineSales@DometicUSA.com

24/7 Tech Support for United States & Canada:

8:00 AM to 5:00 PM Eastern Time: 800-542-2477
After hours and weekends: 888-440-4494

International Sales & Service:

Europe & the Middle East: Call +44(0)870-330-6101
For all other areas visit our website to find your nearest distributor.



Environmentally Responsible

Dealer:

MTS Chillers

For Pleasure Yachts & Commercial Vessels



MTS25 shown



The MTS is a high-capacity modular chiller unit for large pleasure yachts and commercial vessels. Optional electric heaters can provide onboard comfort year round.

Each module contains a hermetic scroll compressor and shell-and-tube marine-grade condenser, along with other mechanical and electrical components on a single chassis. Multiple modules can be staged as needed to meet the required load.

These space-saving modules are designed for easy installation in tight spaces. The MTS provides easy front access for repair and maintenance of condenser tubes, heater rods, flow switch, compressor, and replaceable drier cores. Safety measures include high-pressure switch, refrigerant pressure-relief valve, low-pressure switch, flow switch, high-limit switch, and freeze protection.

A filter drier keeps refrigerant oil clean and dry for long compressor life. With 100 percent pump-down capacity, refrigerant circuit repairs can be made without recovering the refrigerant.

The MTS 25-ton (279,000 BTU/hr) chiller is available in 380V and 460V models.

Key Benefits

- Modular design for staging multiple units.
- Hermetic scroll compressor – avoids leaks.
- Marine-grade cupronickel shell-and-tube condenser.
- Dual bottom-draining liquid connections and trap in condenser – optimal performance in choppy seas.
- High-pressure switch and pressure-relief valve for safety.
- Frequency drives – minimize starting amps.
- Filter drier – keeps refrigerant oil clean and dry for long compressor life.
- 100% pump-down capacity – refrigerant circuit repairs can be made without recovering the refrigerant.

Technical Specifications for MTS 25-Ton

Model	MTS25 (380V)	MTS25 (460V)
Capacity (BTU/Hr)	279,000	279,000
Voltage	380/60/3	460/60/3
Amps	35.5	35.5
Net Weight (lbs/kg)	1150/429.2	1150/429.2
Height (in/mm)	61.2/1554.48	61.2/1554.48
Width, W1 (in/mm)	19.5/495.3	19.5/495.3
Width, W2 (in/mm)	21.75/552.45	21.75/552.45
Depth, D1 (in/mm)	35.5/901.7	35.5/901.7
Depth, D2 (in/mm)	40.2/1021.08	40.2/1021.08
Clearance, C1 (in/mm)	5/127	5/127
Clearance, C2 (in/mm)	10/254	10/254
Manifolds (see notes)	See notes below	See notes below

Notes:

Allow 8" for manifolds only, or 14" for manifolds with isolation valves. All dimensions +/- 0.5 inch. Clearance between modules should alternate 5", 10", 5"... and at least 5" at each end.

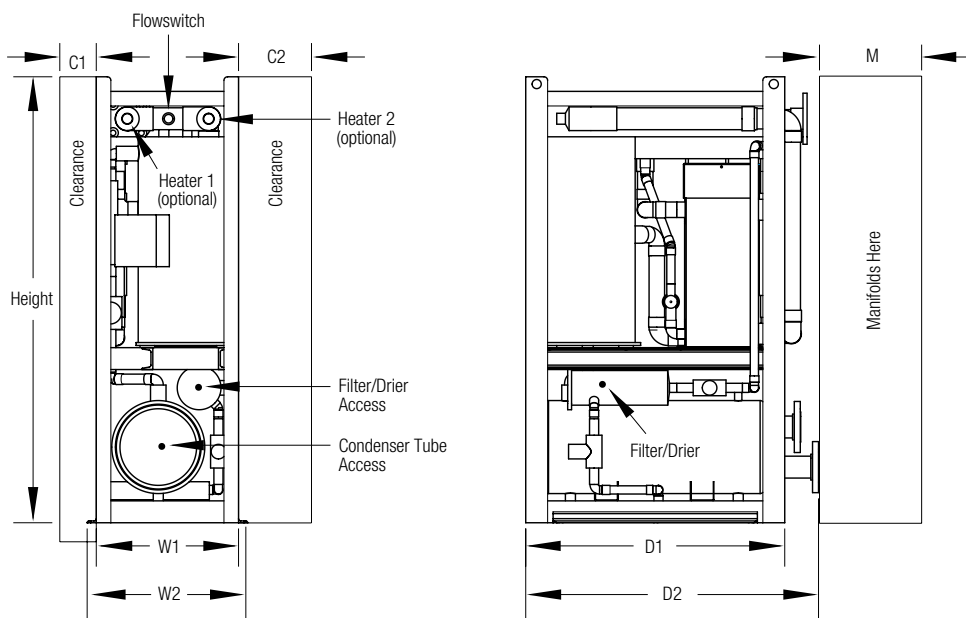

DOMETIC MARINE DIVISION

2000 N. Andrews Ave. Ext. | Pompano Beach, FL 33069 USA | 954-973-2477 | Fax 954-979-4414
 www.DometicUSA.com | MarineSales@DometicUSA.com

24/7 Tech Support for United States & Canada:

8:00 AM to 5:00 PM Eastern Time: 800-542-2477
 After hours and weekends: 888-440-4494

International Sales & Service:

Europe & the Middle East: Call +44(0)870-330-6101
 For all other areas visit our website to find your nearest distributor.



Environmentally Responsible

Dealer:

AT Air Handlers for Chilled Water

Improved Design for Better Performance



AT18HV Air Handler



Marine Air's AT series of air handlers for chilled water systems are draw-through (ducted) units that replace the Flex-Duct and Draw-Through models, and have many improvements and options over the older units.

Significant improvements include: sloped "Positive-Flow" drain pan which reduces standing water, larger drain connections, improved coil design for better cooling and dehumidifying performance, coil is offset from drain pan edge to ensure all condensation is caught in the pan, redesigned piping so the bypass valve is clear of dripping condensation, pressure test ports for troubleshooting, and the new 24,000 BTU/hr unit uses a high-efficiency, internal-motor blower for quieter operation. On units with auxiliary (electric) heat, the new heater design allows removal from the top or side for access or servicing.

Options for "HV" Models:

- Electric heat with two-stage electric heat overload (no thermo-fuse), heater assembly accessible from top or side.
- Modulating flow control to ensure uniform water distribution.
- Corrosion resistant coated evaporator coil.
- Pre-rotated blowers.
- Right-hand water connections.
- 3Ph electric heat available.

Options for "F" Models:

- Electric heat with two-stage electric heat overload (no thermo-fuse), heater assembly accessible from top or side.
- Low-cost, shaded-pole, external-motor blowers.
- No-Valve units.

Key Benefits

- Compact design.
- High-efficiency PSC internal-motor blower is standard ("HV" models).
- Improved cooling and dehumidification.
- Sloped, positive-flow, anti-slosh drain pan with anti-fungal foam insulation.
- Integrated chassis with vibration isolation.
- Exposed sheet metal is insulated to prevent secondary condensation.
- Remote air bleeder on 6' (1.8m) of flexible tubing with ball valve.
- User friendly, remote electrical junction box with 6' (1.9m) wire harness.
- 24K unit with high-efficiency internal-motor blower.
- Water pressure test ports for troubleshooting.
- Allowance for connecting variable fan speed drives.
- Rotatable blowers.
- Washable air filter included. Micro-Particle Anti-Allergenic air filters available.
- ISTA certified packaging.

Technical Specifications for AT Series Air Handlers

Model ⁽¹⁾	AT4HV		AT6HV		AT9HV		AT12HV		AT18HV		AT24HV		AT36HV
Cooling (BTU/hr / Kcal/hr)	4,000/1,008		6,000/1,512		9,000/2,268		12,000/3,024		18,000/4,536		24,000/6,048		36,000/9,072
Voltage @ 50-60Hz/1Ph	115	230	115	230	115	230	115	230	115	230	115	230	230
Amperage (FLA) Cool	0.8	0.4	1.2	0.6	1.4	0.7	1.4	0.7	2.2	1.0	2.2	1.0	1.6
Optional Electric Heaters⁽²⁾													
Element Size (kW)	N/A		1.0		1.5		2.0		3.0		3.0		4.0
Heating (BTU/hr / Kcal/hr)	N/A		3,412/860		5,118/1,290		6,824/1,720		10,236/2,579		10,236/2,579		13,648/3,439
Amperage (FLA) Heat	N/A		10.5	4.9	14.4	7.2	18.8	9.4	28.3	14.0	28.2	14.0	19.0
Max. Fuse/in. Circuit Ampacity													
Without Electric Heat	5/2	5/1	5/3	5/1	5/2	5/1	5/2	5/1	5/3	5/2	5/3	5/2	5/3
With Electric Heat Open	N/A		10/9	5/5	15/14	10/7	20/18	10/9	30/27	15/14	30/27	15/14	25/20
Water Flow (GPM/LPM)	1.0/3.8		1.5/5.7		2.3/8.5		3.0/11.4		4.5/17.0		6.0/22.7		9.0/34.1
Air Flow (CFM / M ³ /Hr) Nominal	130/221		229/389		278/472		338/574		465/790		506/860		676/1149
External SP (in. H2O/eq. Ft.)	0.30/42.3		0.30/42.3		0.30/42.3		0.30/42.3		0.30/42.3		0.30/42.3		0.30/42.3
Height Excluding Blower (in/mm)	10.1/257		10.2/259		11.90/302		12.05/306		14.96/380		16.61/422		19.50/495
Height to Blower (in/mm)	9.5/241		12.63/321		13.25/337		13.88/353		16.50/419		16.68/424		19.50/495
Width (in/mm) ⁽³⁾	14.8/376		15.00/381		16.63/422		18.75/476		20.25/514		22.63/575		26.63/676
Depth (in/mm) ⁽³⁾	8.8/224		12.28/312		12.50/318		12.50/318		12.25/311		15.25/387		18.00/457
Supply Air Duct Diameter (in/mm)	4/102		5/127		6/152		6/152		7/178		8/203		8/203
Remote Mount Electric Box (in/mm)	8.00/203 High X 6.13/156 Wide X 2.00/51 Deep												
Return Air Inlet (sq in/sq cm)	64/413		70/452		98/632		130/839		200/1,290		240/1,548		360/2,323
Supply Air Outlet (sq in/sq cm)	32/206		35/226		49/316		70/452		100/645		140/903		196/1,265
Water Connections	Drain: 1/2" FPT with PVC HB. Chilled Water: 1/2" FPT on 4-24K; 1" FPT on 36K with Brass HB on All.												
Net Weight (lb/kg) ⁽⁴⁾	16.0/7.3		18.4/8.3		24.0/10.9		24.0/10.9		32.8/14.9		38.0/17.2		60.0/27.2
Gross Weight (lb/kg) ⁽⁴⁾	23.0/10.4		28.4/12.9		34.0/15.4		34.0/15.4		36.8/16.7		52.0/23.6		66.0/29.2

Notes:

- ⁽¹⁾ Model numbers shown are for 115V units. Add a "Z" after the "HV" in the model number to designate 230V (i.e. AT12HVZ). Model number prefixes: -FC = Flow Control; -L# or -R# = Valve and Blower Rotation (see dwg H3050002); -#kW = Electric Heat Option.
- ⁽²⁾ Auxiliary heating elements are optional, and must be ordered with unit. Add "1KW, 1.5KW, etc." to the model number.
- ⁽³⁾ Rotatable feet affect the final dimensions. Front feet add 1.5" to the front, or 1.1" to both sides. Rear feet do not add to the width or depth when rotated to the side.
- ⁽⁴⁾ Weights listed are for standard "HV" units. For weights of units with the electric heater option, add heater elements weights to unit weight. 1.0kW & 1.5kW = 1.5 lbs/0.7 kg; 2.0kW & 3.0kW = 3.0 lbs/1.4 kg. Dimensional weights may apply to shipping charges; contact your sales-admin representative.

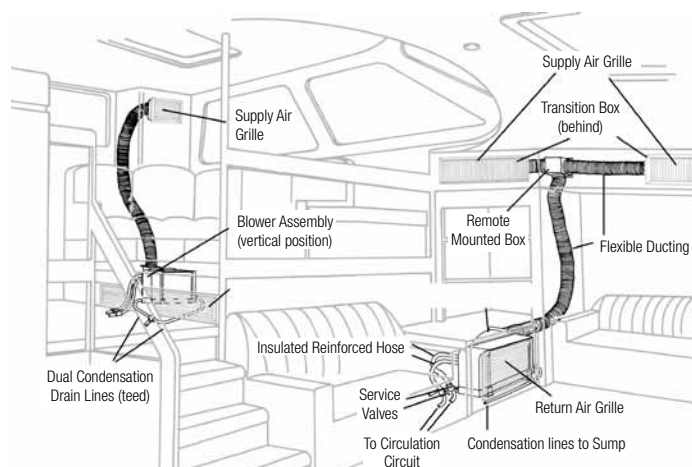
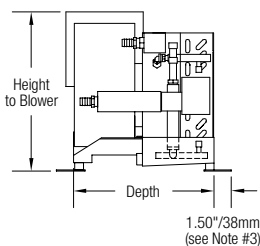
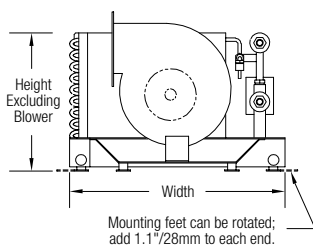

DOMETIC MARINE DIVISION

2000 N. Andrews Ave. Ext. I Pompano Beach, FL 33069 USA | 954-973-2477 | Fax 954-979-4414
www.DometicUSA.com | MarineSales@DometicUSA.com

24/7 Tech Support for United States & Canada:

8:00 AM to 5:00 PM Eastern Time: 800-542-2477
After hours and weekends: 888-440-4494

International Sales & Service:

Europe & the Middle East: Call +44(0)870-330-6101
For all other areas visit our website to find your nearest distributor.



Environmentally Responsible

Dealer:

Super Quiet AT-DC Air Handlers

With WhisperCool Technology



AT6DC shown

Dometic creates the new standard in luxury yacht climate control that you'll barely notice - precisely what your clients are asking for - quiet nights. WhisperCool Technology harnesses engineering refinements to eliminate annoying "motor hum" from traditional air conditioning blowers that occurs at very low speeds. Incoming alternating current is converted to drive a high-efficiency, brushless DC fan motor. The result is a much quieter fan operating across a broad range of variable speeds, permitting the user to select the desired comfort level.

Additional design changes in the air handlers eliminate condensate drain problems, reduce dripping condensation and standing water issues. An improved coil enhances cooling and dehumidification performance. The redesigned unit also creates easily accessible water-pressure test points for troubleshooting and maintenance.

Better dehumidification, better cooling, less noise... just the kind of performance one expects aboard a luxury yacht.

Key Benefits

- Advanced super-quiet variable speed DC fan motor.
- Operates with Marine Air chilled water air conditioning systems.
- Engineering improvements eliminate condensate drain challenges – a positive-flow drain pan, larger drain connections, offset coil from drain-pan edge and a redesigned bypass valve.
- Improved coil design for better dehumidification and cooling.
- More accessible maintenance points including water pressure test ports.
- Rotateable blower.

Technical Specifications for AT-DC Air Handlers

Model	AT6DC	AT9DC	AT12DC	AT18DC	AT24DC	AT36DC
Capacity (BTU/Hr)	6,000	9,000	12,000	18,000	24,000	36,000
Volts/Hz/Phase	208-230/ 50-60/1	208-230/ 50-60/1	208-230/ 50-60/1	208-230/ 50-60/1	208-230/ 50-60/1	208-230/ 50-60/1
Amps (FLA) Cool*	1.4	1.4	3.2	3.9	3.9	3.9
Optional Heater KW	1.0	1.0	1.5	1.5	3.0	3.0
Heater Amps	4.3	4.3	6.5	6.5	13.0	13.0
Amps (FLA) Heat*	5.7	5.7	9.7	10.4	16.9	16.9
Max Fuse						
Without Electric Heat	5.0	5.0	5.0	5.0	5.0	5.0
With Electric Heat	10.0	10.0	15.0	15.0	20.0	20.0
Min Circuit Ampacity						
Without Electric Heat	2.0	2.0	4.0	5.0	5.0	5.0
With Electric Heat	7.0	7.0	11.0	12.0	18.0	18.0
GPM/(liters/min)	1.50/5.7	2.25/8.5	3.00/11.4	4.50/17.0	6.00/22.7	9.00/34.1
CFM/(M ³ /hr)	200/340	280/476	400/680	600/1019	650/1105	670/1130
External Static Pressure (in H ₂ O)	1.9	0.6	2.3	1.1	0.6	0.5
Dimensions (in/mm)						
Height with blower (H1)	13.63/346	13.73/349	13.94/354	16.94/430	16.70/424	19.74/501
Height without blower (H2)	11.08/281	11.79/299	12.05/306	14.83/377	16.70/424	19.74/501
Width (W)	14.81/376	16.48/419	18.75/476	20.08/510	22.48/571	26.41/671
Depth (D)	14.27/362	14.55/370	14.49/368	14.83/377	16.42/417	17.15/436
Duct Ring Diameter (in/mm)	5.00/127.0	6.00/152.4	6.00/152.4	7.00/177.8	8.00/203.2	8.00/203.2
Minimum Supply Air Outlet (sq. in.)	35	49	70	100	140	196
Minimum Return Air Inlet (sq. in.)	70	98	130	200	240	360
Drain Connections	two 1/2" female NPT	two 1/2" female NPT	two 1/2" female NPT	two 1/2" female NPT	two 1/2" female NPT	two 1/2" female NPT
Chilled Water Connections, Female NPT	1/2"	1/2"	1/2"	1/2"	1/2"	1"
Net Weight (lbs/kg)	23/10.4	27/12.2	29/13.2	39/17.7	44/20.0	63/28.6
Gross Weight (lbs/kg)	33/15.0	37/16.8	39/17.7	49/22.2	58/26.3	72/32.7

* Amps listed above are based on maximum speed in free air. Speed would be set well below maximum, and the unit would ordinarily be ducted rather than free air, therefore, the real world amps will be considerably lower.

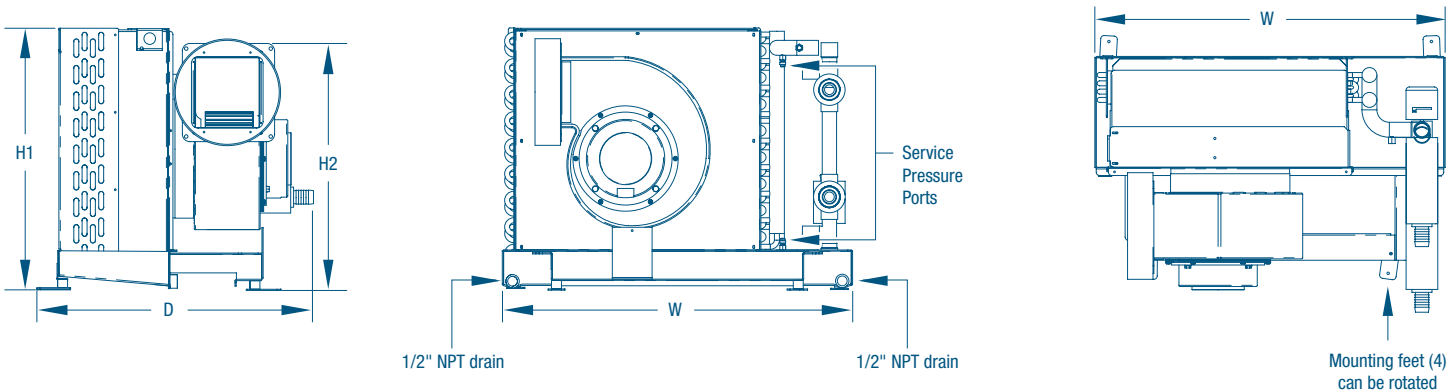

DOMETIC MARINE DIVISION

2000 N. Andrews Ave. Ext. I Pompano Beach, FL 33069 USA | 954-973-2477 | Fax 954-979-4414
 www.DometicUSA.com | MarineSales@DometicUSA.com

24/7 Tech Support for United States & Canada:

8:00 AM to 5:00 PM Eastern Time: 800-542-2477
 After hours and weekends: 888-440-4494

International Sales & Service:

Europe & the Middle East: Call +44(0)870-330-6101
 For all other areas visit our website to find your nearest distributor.



Environmentally Responsible

Dealer:

ATL Chilled Water Air Handlers

Designed With Height Constraints In Mind



ATL12DC shown

Marine Air's ATL air handlers are improved low-profile, draw-through units for chilled water air conditioning systems. Insulating foam covers the condensate pan, blower housing, shroud, and coil end cover to reduce noise and secondary condensation. The condensate pan also has an anti-slosh, anti-fungal foam lining. The ATL series is designed to replace the CHEBC models.

ATL air handlers are an excellent choice for over-head applications where height is limited. Typically, each cabin or area has one or more air handlers with an independent climate control to provide passengers with the most comfortable environment on the water.

All Marine Air air handlers use corrosion-resistant materials, and are fully insulated with deep drain pans to prevent secondary condensation.

Key Benefits

- Suspend from above or support from beneath, vibration isolation included.
- Bypass valve has removable power head for simple servicing.
- Valve body is soldered to unit to prevent leaks.
- The electrical box can be mounted remotely up to six feet away.
- Remote air bleeder on six feet (1.8m) of flexible tubing with easy-operating ball valve.
- Optional whisper-quiet DC blowers.
- Valve on left (standard) or on right (optional).
- Flow control helps balance chilled water distribution throughout the boat by ensuring that no air handler so equipped receives more flow than required. This eliminates the tedious job of trying to manually balance system flow.

Technical Specifications for ATL Air Handlers

Model	ATL6DC	ATL9DC	ATL12DC	ATL18DC	ATL24DC	ATL30DC	ATL36DC	ATL16F
Capacity (BTU/hr)	6000	9000	12000	18000	24000	30000	36000	16000
Volts/Hz/Phase	208-230/ 50-60/1	208-230/ 50-60/1	208-230/ 50-60/1	208-230/ 50-60/1	208-230/ 50-60/1	208-230/ 50-60/1	208-230/ 50-60/1	115/60/1
Amps (FLA) Cool ⁽¹⁾	1.4	1.4	2.8	2.8	3.9	3.9	3.9	2.4
Optional Heater kW ⁽²⁾	1	1	2.0	2.0	1.5	1.5	1.5	N/A
Heater Amps	4.3	4.3	8.7	8.7	6.5	6.5	6.5	N/A
Amps (FLA) Heat ⁽¹⁾	5.7	5.7	11.5	11.5	10.4	10.4	10.4	N/A
Max. Fuse								
Without Elec. Heat	5	5	5	5	5	5	5	5
With Elec. Heat	10	10	15	15	15	15	15	N/A
Min. Circuit Amps								
Without Elec. Heat	2	2	4	4	5	10	10	3
With Elec. Heat	7	7	13	13	12	12	12	N/A
Water Flow, GPM/(liters/min)	1.5/5.7	2.25/8.5	3/11	4.5/17	6/23	7.5/28	9/34	4/15
Air Flow, CFM/(m ³ /hr)	200/340	300/510	400/680	600/1020	800/1360	1000/1700	1200/2040	420/710
External Static Pressure (in H ₂ O/Pa)	1.9/470	0.65/160	1.9/470	0.65/160	1.5/370	1.65/410	0.65/160	0.3/75
Dimensions⁽³⁾								
Height (in/mm)	8.3/211	8.3/211	8.3/211	8.3/211	10.8/274	10.8/274	10.8/274	8.10/205
Depth (in/mm) ⁽⁴⁾	22.7/577	22.7/577	22.7/577	22.7/577	19.7/500	21.6/549	21.6/549	17.60/447
Width (in/mm)	19.4/493	19.4/493	31.4/798	31.4/798	43.1/1095	62.2/1580	62.2/1580	23.40/595
Duct Connections (in/mm)	6/153, 1 ring	6/153, 1 ring	6/153, 2 rings	6/153, 2 rings	8/204, 1 ring	8/204, 1 ring	8/204, 1 ring	4/102, 2 obrounds
Min Supply Air Outlet Per Duct (in ² /cm ²)	35/226 1 duct	49/316 1 duct	35/226 2 ducts	49/316 2 ducts	147/949 1 duct	168/1084 1 duct	168/1084 1 duct	40/260 2 ducts
Total Return Air Inlet (in ² /cm ²)	70/452	98/632	130/840	200/1290	240/1550	300/1935	360/930	144/930
Drain Connections	Two 1/2" od tube stubs							
Chilled Water Connections, Female NPT (in)	1/2	1/2	1/2	1/2	1/2	1/2	1/2	1/2
Pan Style	Sloped	Sloped	Sloped	Sloped	Sloped	Sloped	Sloped	Sloped
Weight (lbs/kg)	31/14.1	31/14.0	51/23.1	51/23.1	62/28.1	76/34.5	76/34.5	34/15.4

Notes:

- ⁽¹⁾ Blower amps will be reduced at lower speed/cfm static pressure.
- ⁽²⁾ The ATL12DC - ATL18DC models are rated at 2.0 kW because the heat is on the blower discharge, and these models have dual blowers. The larger ATL24DC - ATL36DC models require only 1.5 kW because they have a single blower.
- ⁽³⁾ Dimensions are ± 0.3" or 8mm.
- ⁽⁴⁾ Units with electric heat have a heater box on the discharge of each blower. Electric heat adds 5.80"/147mm to the depth. The heater box is only 9.50"/241mm wide (not including electrical gland), and does not add to the height or width of the unit.

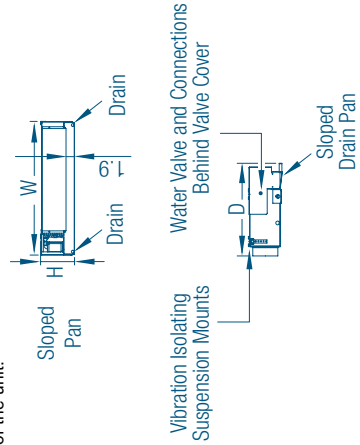

DOMETIC MARINE DIVISION
 2000 N. Andrews Ave. Ext. J Pompano Beach, FL 33069 USA | 954-973-2477 | Fax 954-979-4414
www.DometicUSA.com | MarineSales@DometicUSA.com

24/7 Tech Support for United States & Canada:
 8:00 AM to 5:00 PM Eastern Time: 800-542-2477
 After hours and weekends: 888-440-4494

International Sales & Service:
 Europe & the Middle East: Call +44(0)870-330-6101
 For all other areas visit our website to find your nearest distributor.



Dealer:

ABL Chilled Water Air Handlers

Low-Profile Models



ABL18DCZ shown

Marine Air's ABL air handlers are improved low-profile, draw-through units for chilled water air conditioning systems. Insulating foam covers the condensate pan, blower housing, shroud, and coil end cover to reduce noise and secondary condensation. The condensate pan also has an anti-slosh, anti-fungal foam lining. The ABL series is designed to replace the CBLB models.

ABL air handlers are an excellent choice for over-head applications where height is limited. Typically, each cabin or area has one or more air handlers with an independent climate control to provide passengers with the most comfortable environment on the water.

Key Benefits

- DC blowers are strong and quiet at any speed.
- Suspend from above or support from beneath, vibration isolation included.
- Heater elements accessible from underneath (standard) or from above (optional).
- Bypass valve has removable power head for simple servicing.
- Valve body is soldered to unit to prevent leaks.
- The electrical box can be mounted remotely up to six feet away.
- Remote air bleeder on six feet (1.8m) of flexible tubing with easy-operating ball valve.
- Washable air filter included. Micro-Particle Anti-Allergenic air filters available.

Optional Features

- Valve on left (standard) or on right (optional).
- Heater elements accessible from underneath (standard) or from above (optional).
- Flow control helps balance chilled water distribution throughout the boat by ensuring that no air handler so equipped receives more flow than required. This eliminates the tedious job of trying to manually balance system flow.

Technical Specifications for ABL Air Handlers

Model	ABL18DCZ	ABL24DCZ
Capacity (BTU/Hr)	18,000	24,000
Voltage	208-230/50-60/1	208-230/50-60/1
Amps (FLA) Cool	6.4	6.4
Optional Heater KW	3	3
Heater Amps	13.04	13.04
Amps (FLA) Heat	19.4	19.4
Max. Fuse		
Without Electric Heat	10	10
With Electric Heat	25	25
Min. Circuit Ampacity		
Without Electric Heat	8	8
With Electric Heat	21	21
GPM	4.5	6
CFM	600	800
External static pressure (in H ₂ O)	2.7	2.5
Dimensions (in/mm)		
Height Ceiling Mount, H-CM	11.9/302.25	11.9/302.25
Height Floor Mount, H-FM	12.2/309.90	12.2/309.90
Width, W	37.3/947.40	43.3/1099.80
Depth, D	15.8/401.30	15.8/401.30
Dual Duct Rings (in/mm)	6/152.40	6/152.40
Total Return Air Inlet (sq in)	200	240
Supply Air Outlet for Each Blower (sq in)	50 + 50	70 + 70
Drain Connections, Female NPT (in)	1/2"	1/2"
Chilled Water Connections, Female NPT (in)	1/2"	1/2"
Net Weight (lbs/kg)	63/28.35	66/29.94
Gross Weight (lbs/kg)	72/32.40	81/36.74

Notes:

Dimensions are ± 0.3 inches or 7.62 mm. Blower amps will be reduced at lower speed/cfm/static pressure.

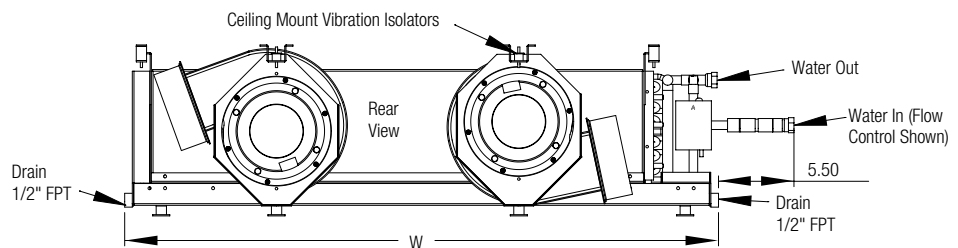
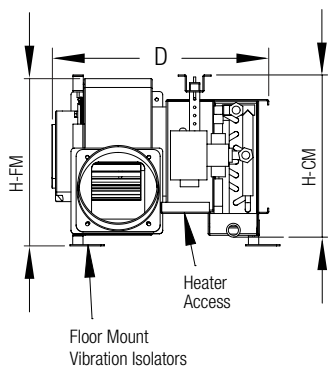

DOMETIC MARINE DIVISION

2000 N. Andrews Ave. Ext. I Pompano Beach, FL 33069 USA | 954-973-2477 | Fax 954-979-4414
 www.DomesticUSA.com | MarineSales@DomesticUSA.com

24/7 Tech Support for United States & Canada:

8:00 AM to 5:00 PM Eastern Time: 800-542-2477
 After hours and weekends: 888-440-4494

International Sales & Service:

Europe & the Middle East: Call +44(0)870-330-6101
 For all other areas visit our website to find your nearest distributor.



Environmentally Responsible

Dealer:

ATV Chilled Water Air Handlers

Designed With Depth Constraints In Mind



ATV6DC
model

Marine Air's ATV chilled water air handlers were designed for applications where very little depth is available. Showcasing a unique vertical layout, this model has the coil low and the blower above.

Put it in the wall. Tall and slim, the ATV makes previously unusable areas suitable for blower installation. With a depth of only 9.4 in. (240 mm) it can be hidden in side areas instead of in places above or below, where most air handlers go. Designed for ducted applications, the ATV has a strong yet quiet DC blower with internal motor to reduce depth, resulting in easier installation.

Heat is just a button-press away. Typically, each cabin or living space has one or more air handlers, each with an independent climate control to provide passengers with the most comfortable environment on the water. The ATV air handler includes an electric heater to provide supplemental heat in cold climates. The ATV can also provide heat to its cabin even while the chiller is supplying cool air to other areas.

Marine Air air handlers have deep drain pans, use corrosion-resistant materials, and are fully insulated to prevent secondary condensation. An optional flow control is highly recommended to help distribute the flow of chilled water more efficiently.

Key Benefits

- Fits into walls.
- Unique vertical design.
- Minimal depth.
- DC blower provides strong, quiet performance.
- Electric heater included.
- Capacities from 6K - 36K BTU/hr.

Technical Specifications for ATV Chilled Water Air Handlers

Model	ATV6DC	ATV9DC	ATV12DC	ATV18DC	ATV24DC	ATV36DC
Capacity (BTU/Hr)	6,000	9,000	12,000	18,000	24,000	36,000
Volts/Hz/Ph	208-230/50-60/1	208-230/50-60/1	208-230/50-60/1	208-230/50-60/1	208-230/50-60/1	208-230/50-60/1
Amps (FLA) Cool	1.4	1.4	3.2	3.9	3.9	3.9
Optional Heater KW	1.0	1.0	1.0	1.5	1.5	1.5
Heater Amps	4.3	4.3	4.3	6.5	6.5	6.5
Amps (FLA) Heat	5.7	5.7	7.5	10.4	10.4	10.4
Max. Fuse						
Without Electric Heat	5.0	5.0	5.0	5.0	5.0	5.0
With Electric Heat	10.0	10.0	10.0	15.0	15.0	15.0
Water Flow, GPM (liters/min)	2.25/8.5	2.25/8.5	3.00/11	3.00/11	6.00/23	9.00/34
Air Flow, CFM (m ³ /hr)	200/340 ⁽²⁾	280/476	400/680 ⁽²⁾	600/1020 ⁽²⁾	650/1100	750/1275
External static pressure (in H ₂ O/Pa)	0.75/186	0.75/186	0.75/186	0.75/186	0.75/186	0.50/125
Dimensions (in/mm)⁽³⁾						
Height	22.3/566	22.3/566	24.1/612	27.8/706	34.4/874	34.4/874
Width	20.2/513	20.2/513	20.2/513	21.2/538	29.3/538	29.3/538
H-B	20.5/521	20.5/521	22.1/561	26.0/660	32.5/826	32.5/826
D-P	4.3/109	4.3/109	4.3/109	6.3/160	7.9/201	7.9/201
D-V	6.8/173	6.8/173	6.8/173	7.6/193	9.1/231	9.1/231
D-B	7.4/188	9.4/240	9.4/240	10.3/262	11.5/292	11.5/292
Duct Ring Diameter (in/mm)	5.0/127	6.0/152	6.0/152	7.0/178	8.0/203	8.0/203
Minimum Supply Air Outlet (in ² /cm ²)	35/226	49/320	70/450	100/645	140/903	196/1,265
Minimum Return Air Inlet (in ² /cm ²)	70/452	98/632	130/839	200/1,290	240/1,548	360/2,323
Drain Connections, Female NPT	1/2"	1/2"	1/2"	1/2"	1/2"	1/2"
Chilled Water Connections, Female NPT	1/2"	1/2"	1/2"	1/2"	1"	1"
Net Weight (lb/kg)	22/10	25/11	31/14	36/16	65/29	65/29
Gross Weight (lb/kg)	32/15	32/15	40/18	46/21	76/34	76/34

Notes:

- ⁽¹⁾ Blower amps will be reduced at lower speed/cfm/static pressure.
- ⁽²⁾ To avoid water droplets in the airstream, do not exceed this CFM.
- ⁽³⁾ Dimensions are ± 0.3 inches or 8mm.

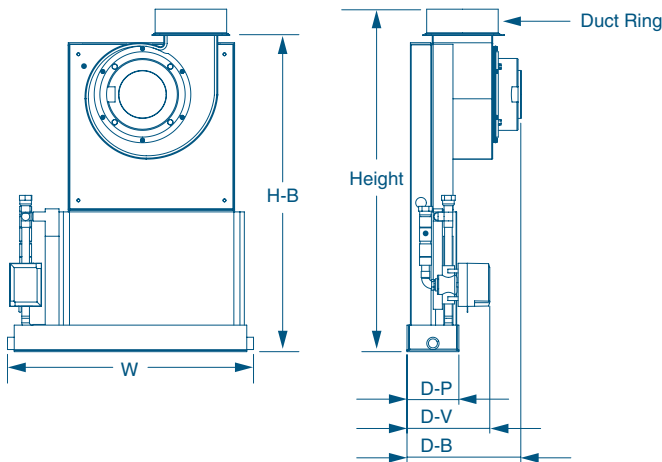

DOMETIC MARINE DIVISION

2000 N. Andrews Ave. Ext. I Pompano Beach, FL 33069 USA | 954-973-2477 | Fax 954-979-4414
 www.DometicUSA.com | MarineSales@DometicUSA.com

24/7 Tech Support for United States & Canada:

8:00 AM to 5:00 PM Eastern Time: 800-542-2477
 After hours and weekends: 888-440-4494

International Sales & Service:

Europe & the Middle East: Call +44(0)870-330-6101
 For all other areas visit our website to find your nearest distributor.



Environmentally
Responsible

Dealer:

AT-MU Fresh Air Make-Up Units

For Use In Fresh Air Make-Up Systems



ATMU 24 shown

Marine Air introduces the new “AT-MU” line of chilled water fresh air makeup air handlers. These are draw-through (ducted) units that replace the current models, and offer many improvements over the existing units.

AT-MU air handlers are designed for use in fresh air make-up (FAMU) systems where outside air is drawn in by the air handler, cooled, dehumidified, and reheated to room temperature, and then ducted to various areas in the vessel. The unit consists of a water coil, valve, electric heater, and a blower mounted on a condensate pan/chassis with rubber isolation mounting feet.

A specially designed water coil cools and dehumidifies the outside air in one pass, and is coated, along with the blower and sheet metal, to prevent corrosion. A motorized 3-way bypass valve controls the flow of circulated water through the coil. The high static pressure blower has a high-efficiency internal motor, and can be rotated as required for installation. An electric heater, with redundant over-temperature protections, is included to reheat the cooled air up to a comfortable temperature.

The sloped “Positive-Flow” condensate pan reduces standing water, and is lined with anti-fungal, anti-slosh foam. An optional modulating loop-water flow control regulates the water through the unit to ensure proper water distribution to all air handlers.

ISO 9001:2008

L-2404 Rev. 20080502

Key Benefits

- Compact design.
- Corrosion resistant coating on evaporator coil, blower, and sheet metal sloped “Positive-Flow” drain pan with anti-slosh, anti-fungal foam.
- Vibration isolation mounting feet.
- Rotatable, high-efficiency internal-motor blower.
- Integrated 3-way bypass valve with easy-change power head.
- Electric heat with two-stage electric heat overload.
- Heater assembly accessible from top or side.
- Large coil shroud volume for optimum performance.
- Washable air filter.
- Brass hose barbs included for loop water connections.
- Remote air bleeder on 6ft (1.8m) of flexible tubing with ball valve.
- Water pressure test ports for troubleshooting.
- Modulating flow control ensures proper water distribution.
- Hose adapter included for round flex duct connection.
- ISTA Level IIIA certified packaging.

Options

- Terminal strip style junction box for use with SMX instead of SCR-based controls. Precise voltage (i.e., 208 or 230) need not be specified with this option.

Technical Specifications for AT-MU Fresh Air Make-up Air Handlers

Model ⁽¹⁾	AT18HVZ-1.5KW-MU	AT24HVZ-2KW-MU	AT36HVZ-4KW-MU
Capacity (BTU/Hr)/(Kcal/Hr)	17,000/4,284	27,000/6,804	53,000/13,356
Voltage @ 50-60Hz/1Ph ⁽²⁾	230	230	230
Amperage (FLA)	7.4	9.5	19.1
Max. Fuse/Min. Circuit Ampacity	10/8	10/10	20/20
Electric Heaters Size (kW)	1.5	2.0	4.0
Water flow GPM/(liters/min.)	4.5/17.0	6.0/22.7	9.0/34.1
CFM/(M3/HR.) NOMINAL	174/296	276/469	550/935
External SP (in. H ₂ O/eq. Pa)	0.72/180	0.36/90	0.75/190
Dimensions (in/mm)⁽³⁾			
Height	15.0/380	16.6/422	19.5/495
Width	20.3/514	22.6/575	26.6/676
Depth	12.3/311	15.3/387	18.0/457
Supply Air Duct Ø	5.0/125	6.0/150	8.0/200
Return Air Inlet (sq in/cm)	100/645	140/900	220/1400
Loop Water Connections	1/2" FPT with 5/8" brass HB		1" FPT with 1" brass HB
Drain Pan Connections	1/2" FPT with PVC 5/8" brass HB		
Net Weight (lbs/kg)	34/15.5	41/18.6	63/28.6
Gross Weight (lbs/kg)	38/17.3	55/25.0	69/31.4

Notes:

⁽¹⁾ Electrical and blower data is based on 50Hz performance.

⁽²⁾ Verify voltage! Units with SCR-based controls are designed for either 208VAC or 230VAC. Add "208" to the end of the model number for 208VAC units.

⁽³⁾ Rotatable feet affect the final dimensions. front feet add 1.5" to the front, or 1.1" to both sides. Rear feet do not add to the width or depth when rotated to the side.

Interpreting Model Numbers

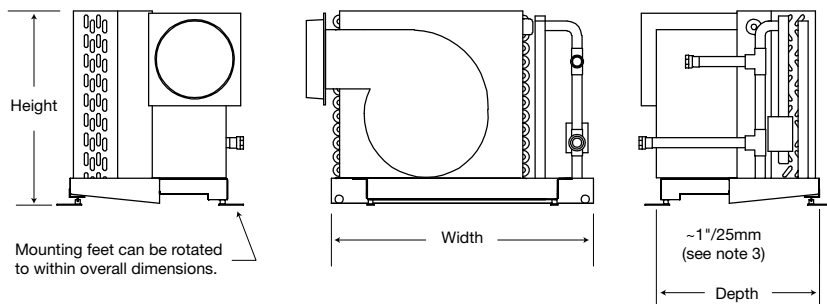
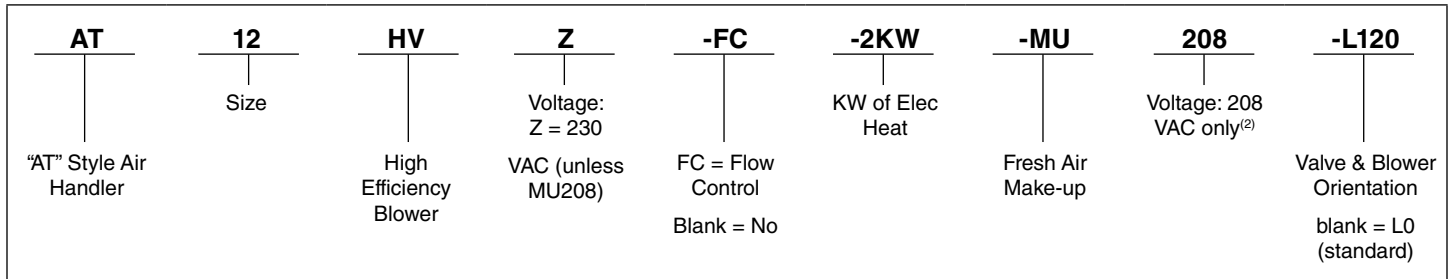

DOMETIC MARINE DIVISION

2000 N. Andrews Ave. Ext. I Pompano Beach, FL 33069 USA | 954-973-2477 | Fax 954-979-4414
www.DometicUSA.com | MarineSales@DometicUSA.com

24/7 Tech Support for United States & Canada:

8:00 AM to 5:00 PM Eastern Time: 800-542-2477
After hours and weekends: 888-440-4494

International Sales & Service:

Europe & the Middle East: Call +44(0)870-330-6101
For all other areas visit our website to find your nearest distributor.



Environmentally Responsible

Dealer:

Fresh Air Make-Up & Extraction Units

Removes Stale Air From the Vessel Interior



T 800 Model shown

A Fresh Air Make Up (FAM) and Extraction systems by Dometic Marine is a must for large displacement yachts, ferries, and commercial vessels.

The FAM system handles the treatment of incoming air and extraction of stale air to keep the vessel interior full of fresh treated air without fear of overpressure.

The system normally consists of a treatment unit with a specially designed water coil which cools and dehumidifies outside air. If needed, the extraction unit captures and extracts the amount of air specified to be removed, either centrally or distributed.

FAM systems are custom designed and built to the requirements of individual vessels. There are many configuration options with two major considerations: Structural/material and treatment/control type. Structural/material options include single walled (standard) or double walled (optional), stainless-steel construction, heavy-duty motors and ventilators, to name a few. Treatment/control options include reheat, humidification, full flow, or balanced flow, and can be controlled by the latest PLC technology or a simple on/off switch.

FAM units are available in single and 3-phase configurations and are tailored to available onboard power.

Key Benefits

- Stainless-steel drain pan.
- Fully assembled.
- Minimum of 6-row coil.
- Field serviceable ventilator.
- Custom designed and built to the client's requirements.

Configuration Options

- Single- or double-wall sheet metal.
- Suspension hardware.
- Large multi-point discharge plenums.
- Flexible treated water flow options.
- Fixed or variable air volume.
- Flexible electric reheat combinations.
- Mist separation and filter types.
- Ducted or free-flow return.
- Direct expansion, chilled and hot water coils.
- Humidification.
- Copper fin coils.
- UV-C germicidal lamps.

Technical Specifications for Fresh Air Make Up & Extraction Systems

Model	Air Volume CFM ⁽¹⁾	BTU/hr Absorption ⁽²⁾	Average 400/3 ⁽³⁾	Dimensions (in/mm) ⁽⁴⁾			
				Height	Width	Depth	With Heater ⁽⁵⁾
T 400	170–260	20,000–27,000	0.39	18.11/460	19.68/500	20.47/520	Width = 28.74/730
T 800	265–400	36,000–52,000	0.39	18.11/460	21.65/550	20.47/520	Width = 30.71/780
T 1000	530–700	76,000–98,000	1.43	21.65/550	23.62/600	39.37/1000	Depth = 45.28/1150
T 1400	700–880	100,000–120,000	1.94	21.65/550	27.56/700	39.37/1000	Depth = 51.18/1300
T 1700	880–1050	120,000–146,000	2.90	27.56/700	27.56/700	43.31/1100	Depth = 55.12/1400
T 2600	1350–1700	190,000–238,000	4.00	27.56/700	38.19/970	43.31/1100	Depth = 55.12/1400

Notes:

- ⁽¹⁾ Pulleys provide adjustable air flow. Actual total air flow depends on the size and length of the plenum.
- ⁽²⁾ Based on entering water of 45°F/7.2°C.
- ⁽³⁾ Based on 400VAC/3-Phase. Actual depends on voltage. Units are available in standard voltages and phase configurations. Note heat amps are not included.
- ⁽⁴⁾ Dimensions for base chilled water unit includes standard filter only and does not include supply and return plenums, heater, demister or double-walled units.
- ⁽⁵⁾ Actual dimensions with heater depends on the quantity of heat required.

Extraction Units:

To maintain balanced air pressure that is slightly positive, it is recommended to use an Extractor that will remove slightly less air than has been added to the vessel by way of the Fresh Air Make Up system. We offer a range of Extraction equipment to suit your needs.

Fresh Air Make Up and Extraction Control Panel:

Vessels are often equipped with multiple Make Up and Extraction units. Each Make Up and Extractor comes with a junction box and contactor (when required). However, when multiple units are utilized, we will provide a unified control panel to centralize control of these components.

Make Up and Extraction Options:

As noted on side 1, Fresh Air Make Up and Extraction Systems are completely customized to the client vessel's requirements. Prior to utilizing the details found in this specification sheet, please contact your technical sales manager. To improve the turn-around of your request, please be prepared to provide the class of the vessel (if applicable), and required air changes. We also need to know if a central or distributed system is needed. Additionally, we recommend that you over-estimate the amount of room required for the units, as the dimensions listed above do not include plenums, ducting, or other optional equipment.

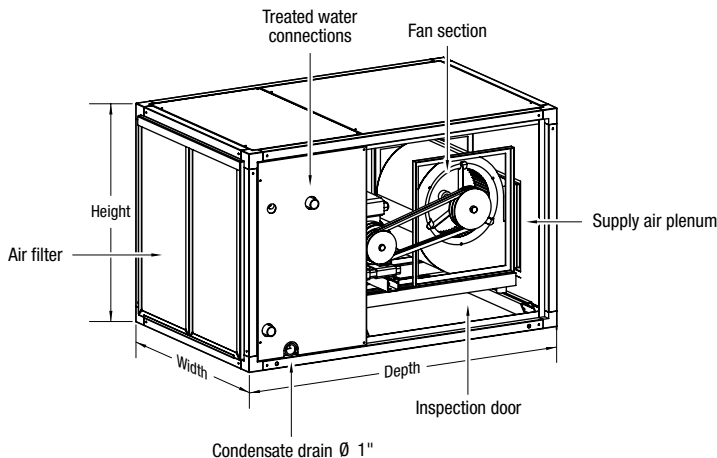

The illustration above shows the Fresh Air Make Up and Extraction system without the optional heater.

DOMETIC MARINE DIVISION

2000 N. Andrews Ave. Ext. I Pompano Beach, FL 33069 USA | 954-973-2477 | Fax 954-979-4414
 www.DometicUSA.com | MarineSales@DometicUSA.com

24/7 Tech Support for United States & Canada:

8:00 AM to 5:00 PM Eastern Time: 800-542-2477
 After hours and weekends: 888-440-4494

International Sales & Service:

Europe & the Middle East: Call +44(0)870-330-6101
 For all other areas visit our website to find your nearest distributor.



Environmentally Responsible

Dealer:

Elite Keypad/Display

Ship-Wide Network Capable

Now Supports
Vimar Eikon



Elite keypad/display
with Vimar Eikon bezel

The Elite™ keypad/display is a microprocessor-based controller designed for the precise monitoring of split and self-contained direct expansion air conditioning systems in marine environments. The control can also be used with chilled-water air handlers and is called the AH-Elite in that application. The control operates at 115 or 230 volts, each operable at 50 or 60 cycles.

The Elite keypad/display has a sleek, modern Euro design. It features a raised buttons for easy access and control. The Mode button is used to scroll through the four modes of operation, simplifying programming. Decorative snap-on Vimar® bezels are available in a variety of colors and materials to match your vessel's interior. The original Elite display, available in grey or white, supports the Vimar Idea line of bezels. A new, second variety of Elite display is now available in grey only that supports the Vimar Eikon line of bezels.



Elite keypad/display
with Vimar Idea bezel

The Elite display operates with the new Passport® I/O circuit board that utilizes state-of-the-art SMT technology. The Passport® I/O circuit board has an optional integrated CAN-bus network adapter that provides ship-wide network monitoring of multiple DX systems and air handlers. The adapter adheres to CAN-bus Standard 2.0B and is fully ISO compliant. It is available in two

Key Benefits

- Automatic humidity control — reduces moisture when the boat is unattended.
- Cool-only, heat-only, dehumidify, or automatic mode selection.
- New optional electric-heat relay.
- Ship-wide network capable.
- Displays Fahrenheit or Celsius.
- Automatic or three manual fan speeds.
- Cycle fan with compressor or continuous fan operation.
- Cycle pump with compressor or continuous pump operation.
- Compressor time-delay staging for multiple unit applications.
- Dimmable display lights.
- Controls shaded pole and split capacitor fan motors.
- Compressor fail-safe protection.
- Programmable de-icing cycle.
- Built in air sensor (optional remote sensor).
- Available with popular Vimar bezel styles (sold separately).

high-level CAN-bus communication protocols to support connection to several popular helm and cabin touchscreen control systems.

The Elite display is flash programmable, which allows for future software upgrades without the need to replace the circuit board. A ground shield protects against static interference and RF noise, and the circuit board is conformally coated to provide high

resistance to external damage or corrosion. A display cable with modular jacks connects the panel to the system controller. Non-volatile memory stores all user-selectable parameters indefinitely during operation and through any power-failure situations.

The Elite control meets or exceeds applicable ABYC, U.S. Coast Guard Regulations and CE Directives.

Technical Specifications

Voltage (VAC)	115	230
Cycle (Hz)	50/60	50/60
Phase (ø)	1	1
Circuits⁽¹⁾		
Compressor Output ⁽²⁾	40A	40A
Locked Rotor Amps (LRA)	80A	80A
R.V. Output ⁽³⁾	¼A	¼A
Fan Output	6A	6A
Heater Output	30A	20A
Pump Output ⁽²⁾	¼ HP	¼ HP
Set Point Temperature Range	65 to 85 / 18 to 29	
Display Temperature Range	5 to 150 / -15 to 66	
Air Sensor Temperature Range	5 to 150 / -15 to 66	
Sensor Accuracy	±2°F at 77°F / ±1.1°C at 25°C	
Cables Included⁽⁴⁾		
Water Inlet Sensor ft./m.	7.00/2.1 cable included with some AH-Elite kits	
Other Cables Available ⁽⁴⁾	Most cables available in 5 ft. (1.5 m.) increments	
Display ft./m.	10 - 75/3.0 - 22.9 (typically 15 ft./4.6 m.)	
Alternate/Remote Air (optional)	7 - 60/2.1 - 18.3	
Outside Air Sensor (optional)	7 - 50/2.1 - 15.2	
Pump Sentry (optional)	7 - 60/2.1 - 18.3	
Water Inlet Sensor (AH-Elite)	7 - 60/2.1 - 18.3	

Dimensions

Bezel Type	Vimar Idea	Vimar Eikon
Elite Display Dimensions (in/mm)		
Height	2.96/75	2.88/73
Width	4.41/112	4.45/113
Depth	1.08/27	1.05/27
Panel Cut-Out Dimensions (in/mm)		
Height	2.19/56	1.88/48
Width	3.31/84	2.75/70
Bezel Dimensions (in/mm)⁽⁵⁾		
Height	3.25/83	3.31/84
Width	4.85/123	4.69/119

Notes:

⁽¹⁾ Maximum loads should not exceed 85% of listed output ratings.

⁽²⁾ Does not apply to AH-Elite.

⁽³⁾ Used as water valve output in AH-Elite mode.

⁽⁴⁾ Maximum length for display and air sensor cables is 75 ft. (22.9 m.). Maximum length for water inlet sensor cable is 75 ft. (22.9 m.).

⁽⁵⁾ Bezels sold separately. Dimensions may vary depending on style.

DOMETIC MARINE DIVISION

2000 N. Andrews Ave. Ext. I Pompano Beach, FL 33069 USA | 954-973-2477 | Fax 954-979-4414
www.DometicUSA.com | MarineSales@DometicUSA.com

24/7 Tech Support for United States & Canada:

8:00 AM to 5:00 PM Eastern Time: 800-542-2477

After hours and weekends: 888-440-4494

International Sales & Service:

Europe & the Middle East: Call +44(0)870-330-6101

For all other areas visit our website to find your nearest distributor.

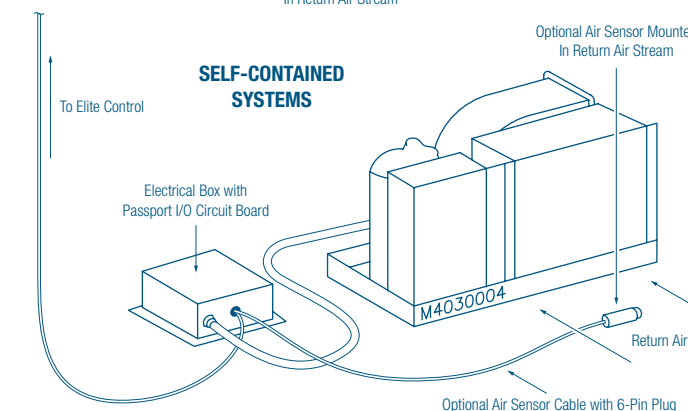
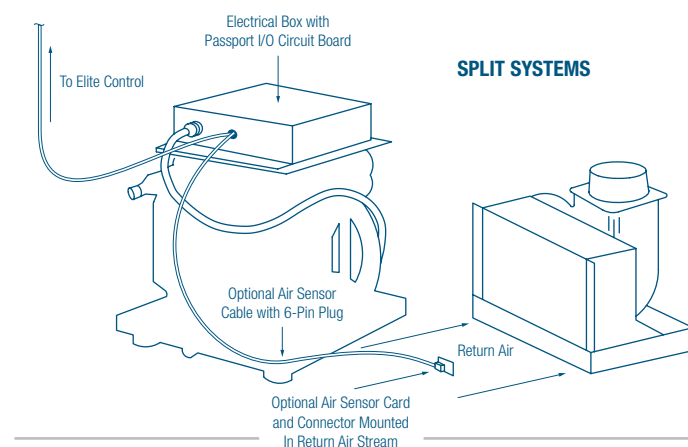
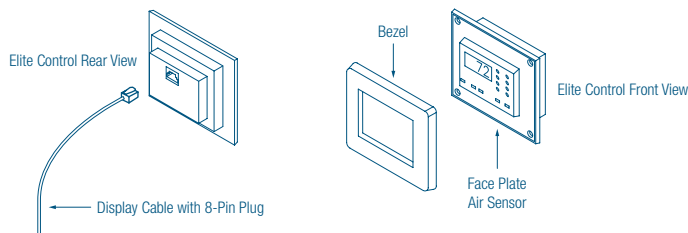

Dealer:



Environmentally Responsible

Passport I/O Digital Control

For DX & Chilled Water A/C Systems

New
Compact
Design!



Passport I/O Compact digital control shown



The Passport I/O Environmental Control Unit is a microprocessor based controller, designed for the precise monitoring of direct expansion and chilled water air conditioning systems in marine environments. The control is dual voltage, operating at both 115 and 230 Volts, 50/60 Hz. The display is available in both black and white. In chilled water air handlers, the control is referred to as AH-Passport I/O.

The assembly has a ground shield to protect against static interference and RF noise. The circuit board is conformally coated to provide high resistance to external damage or corrosion.

A display cable with gold plated phone-type modular jacks connects the panel to the system controller. An optional air sensor cable is connected to the circuit board in the same manner. Non-volatile memory stores all user-selectable parameters indefinitely during operation or any power failure situations.

Internal self-diagnostic programs provide complete electronic checks of all lights, sensors, keys and circuits. Fused circuits and M.O.V.s (metal oxide varistors) provide component and board protection.

The Passport I/O control meets or exceeds applicable ABYC, U.S. Coast Guard Regulations and CE Directives.

Key Benefits

- Automatic humidity control reduces moisture when the boat is unattended.
- Cool only, heat only, or automatic mode selection.
- Temperature displayed in Fahrenheit or Celsius.
- Multiple fan speed selections - automatic or six manual speeds.
- Cycle fan with compressor or continuous fan operation.
- Compressor time delay staging for multiple unit applications.
- Calibration of fan speed settings and temperature display to maintain precise control.
- Blank display lights when desired.
- Controls shaded pole and split capacitor fan motors.
- Compressor fail-safe protection.
- Programmable de-icing cycle.
- Low voltage for optimum safety.
- Built-in air sensor (optional remote sensor).

Technical Specifications for Passport I/O & AH-Passport I/O Environmental Controls

Voltage (VAC)	115	230
Cycle (Hz)	50/60	50/60
Phase (ø)	1	1
Circuits ⁽¹⁾		
Compressor Output ⁽²⁾	40A	40A
Locked Rotor Amps (LRA)	80A	80A
R.V. Output ⁽³⁾	¼A	¼A
Fan Output	6A	6A
Heater Output	30A	20A
Pump Output ⁽²⁾	¼ HP	½ HP
Temperature Ranges °F / °C		
Set Point Temperature	65 to 85 / 18 to 29	
Display Temperature	5 to 150 / -15 to 66	
Air Sensor Temperature	5 to 150 / -15 to 66	
Sensor Accuracy	±2°F at 77°F / ±1.1°C at 25°C	
Display Panel Dimensions (in/mm)	3.19"/81mm W X 2.50"/63.5mm H X 0.94"/23.87mm	
Panel Cut-Out Dimensions (in/mm)	2.50"/63.5mm W X 1.875"/47.63mm	
Cables Included ⁽⁴⁾		
Display ft/m	VCD & VTD: 15/4.6; CMCD: 10/3.0; CSD: 30/9.1; Chilled Water: 15/4.6	
Water Inlet Sensor ft/m	7/2.1 cable included with some AH-Elite and AH-Passport I/O kits	
Other Cables Available ⁽⁵⁾	Most cables available in 5' increments	
Display ft/m	10 - 75/3.0 - 22.9	
Alternate/Remote Air (optional)	7 - 60/2.1 - 18.3	
Outside Air Sensor (optional)	7 - 50/2.1 - 15.2	
Pump Sentry (optional)	7 - 60/2.1 - 18.3	
Water Inlet Sensor (AH-Passport I/O)	7 - 60/2.1 - 18.3	

Notes:

- ⁽¹⁾ Maximum loads should not exceed 85% of listed output ratings.
- ⁽²⁾ Does not apply to AH-Passport I/O.
- ⁽³⁾ Used as water valve output in AH-Passport I/O mode.
- ⁽⁴⁾ Maximum length for display and air sensor cables is 75'. Maximum length for water inlet sensor cable is 75'.

Key Benefits (continued)

- Universal symbols with tactile switches and embossed power key.
- Cabin temperature is continuously displayed.
- Lexan face plate available in black with cameo graphics.
- The circuit board and display cable are factory installed in the electrical box.
- Display panels can be mounted with adhesive strips, or use screws with the optional, soft bulkhead adapter.
- Easy connections using phone-type modular jacks which are shielded and grounded.

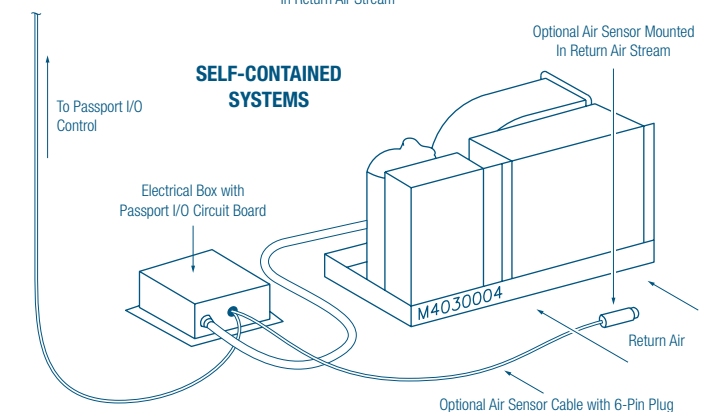
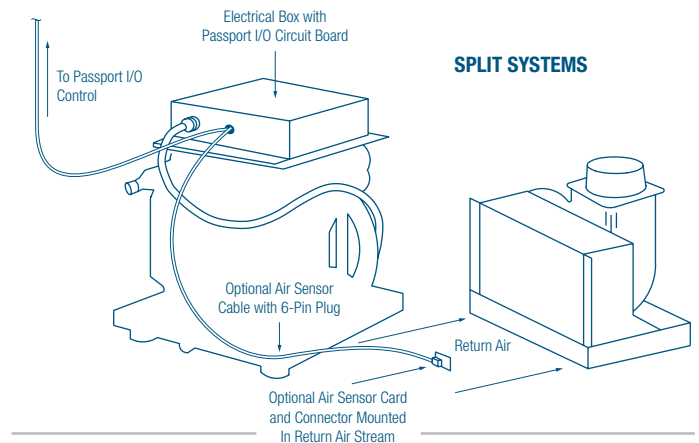
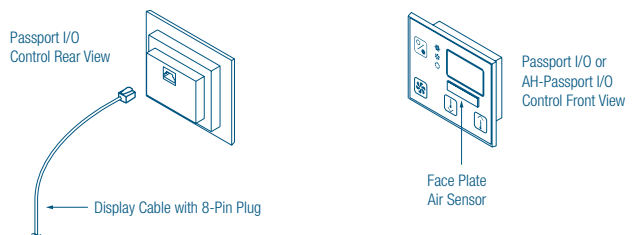

DOMETIC MARINE DIVISION

2000 N. Andrews Ave. Ext. I Pompano Beach, FL 33069 USA | 954-973-2477 | Fax 954-979-4414
 www.DometicUSA.com | MarineSales@DometicUSA.com

24/7 Tech Support for United States & Canada:

8:00 AM to 5:00 PM Eastern Time: 800-542-2477
 After hours and weekends: 888-440-4494

International Sales & Service:

Europe & the Middle East: Call +44(0)870-330-6101
 For all other areas visit our website to find our nearest distributor.

Dealer:



Environmentally Responsible

Chilled Water Master Controller

Precise Chiller Monitoring & Coordination



Digital Diagnostic Controller (DDC) Display/Keypad (far right) with PC (not included)

The Chilled Water Master Controller (CWMC) is a microprocessor based controller designed for the precise monitoring and coordination of Digital Diagnostic Controllers (DDC) for multiple chilled water systems. The control unit provides central control for up to six chillers via interfaces with the individual DDC* on each chiller. It controls all of the heating and cooling functions for each chiller, as well as operation of the seawater and chilled water pumps. It optimizes compressor operation by automatically changing the lead compressor to evenly distribute run time.

The two-line lit LCD display provides a scrolling read-out of system status including inlet and outlet water temperature of each stage, mixed outlet water temperature of the system, compressor run times, and diagnostic faults including refrigerant high and low pressure, flow switch, low voltage, freeze warning, and high water temperature

limit. It also interfaces with a PC via a serial port permitting remote control and monitoring. The PC software also permits the system to be programmed in several different languages. Note that a PC is optional—not required—and the software is available on request.



*The DDC must be version A23 or greater.

(Continued on reverse side)

ISO 9001:2008

L-2133 Rev. 20080829

Key Benefits

- Provides central control for up to six chillers.
- Optimizes compressor operation.
- LCD display shows status of inlet and outlet water temperature of each stage, mixed outlet water temperature of the system, compressor run times, and diagnostic faults.
- Interfaces with a PC (not included, not required) via serial port for remote control and monitoring. Software is available upon request.
- Circuit board is coated for high resistance to damage or corrosion.
- Entire assembly is grounded and protected against static interference and RF noise.
- Meets or exceeds applicable ABYC, U.S. Coast Guard Regulations and CE Directives.

MARINE AIR SYSTEMS®

 by Dometic GROUP

The entire assembly is grounded and protected against static interference and RF noise. The circuit board is conformally coated to provide high resistance to external damage or corrosion.

A display cable with phone-type modular jacks connects the display to the circuit board. The circuit board has two display jacks. One jack is used for the display local to the chiller the second jack allows a second display to be remotely installed on the bridge or elsewhere. Non-volatile memory stores all user-selectable parameters indefinitely during operation or any power failure situations.

What is the difference between the Hydromatic Controller & the CWMC?

Controller Type	CWMC	Hydromatic
Compressor Duty Cycling	Yes	Yes
Fahrenheit/Celsius	Either	Either
High Pressure Monitoring	Integrated	Integrated
Low Pressure Monitoring	Integrated	Integrated
Flow Switch	Integrated	External
Freeze Protection	Integrated	External
High Limit	Integrated	External
Maximum Stages	6	4
Network Compatible	Yes	No
Water Pressure In (System)	Optional	No
Water Pressure Out (System)	Optional	No
Refrigerant Pressure High (Stage)	Optional	No
Refrigerant Pressure Low (Stage)	Optional	No
Hour Meter for Each Stage	Yes	No
Automatic Setpoint Adjustment	Yes(1)	No
Multilingual Programming	Optional (2)	No
Hurry Mode	Yes(3)	No
Remote Monitoring/Diagnostics	Optional(4)	No
Text Display	2-Line Backlit LCD, 16 characters/line	Two 3-digit LEDs

Notes:

- (1) Whenever a stage is bypassed or off due to a fault, the next stage assumes the setpoint of the bypassed stage. Subsequent stages are also adjusted.
- (2) Requires computer attached to serial bus. Message codes can be changed in the field from English to the target language.
- (3) Standard staging delay is adjustable, but when differential is greater than five degrees stages are started 15 seconds apart.
- (4) Requires computer and modem interface.

* Fault indicator circuit not to exceed 250mA, 48VAC/DC (Ref. DWGH1580001).

Internal self-diagnostic programs provide complete electronic checks of all lights, sensors, keys, and circuits. The CWMC controller meets or exceeds applicable ABYC, U.S. Coast Guard Regulations and CE Directives.

Chilled Water Master Controller (CWMC) Typical Installation

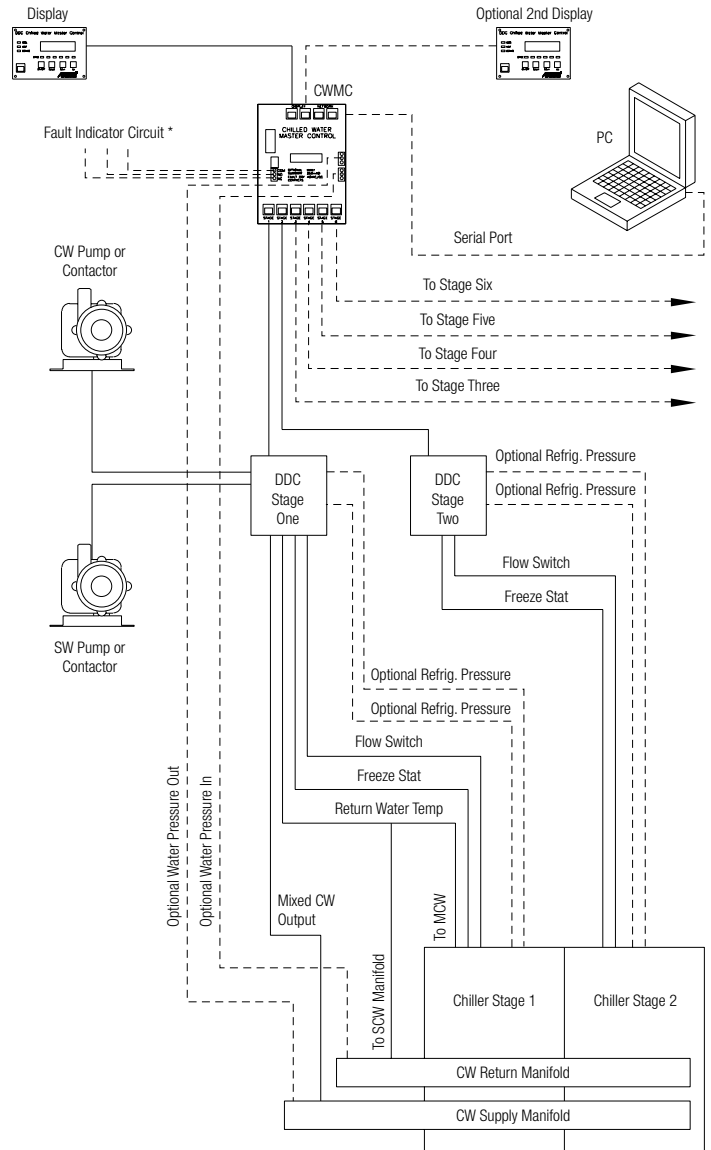

DOMETIC MARINE DIVISION

2000 N. Andrews Ave. Ext. I Pompano Beach, FL 33069 USA | 954-973-2477 | Fax 954-979-4414
 www.DometicUSA.com | MarineSales@DometicUSA.com

24/7 Tech Support for United States & Canada:

8:00 AM to 5:00 PM Eastern Time: 800-542-2477
 After hours and weekends: 888-440-4494

International Sales & Service:

Europe & the Middle East: Call +44(0)870-330-6101
 For all other areas visit our website to find your nearest distributor.



Environmentally Responsible

Dealer:

TWLC for Chilled Water Systems

Advanced Monitoring & Control



Multi-Unit Control
Panel shown



The TWLC (Tempered Water Logic Control) is an advanced microprocessor chiller control specifically designed for marine circulated water systems. The TWLC system maximizes system performance, protects the chillers with advanced fault protection monitoring and shut-down routines, and has easy menu-driven operation supplying the user with important system information.

System redundancy and easy field repair were the priorities when the TWLC was developed. Each chiller in a TWLC system has a dedicated power/logic board, and the boards are networked together to form an integrated system (automatically controlling up to 6 chillers). This design means that a single board or network failure will not shut down the entire system. The P/L board has board-mounted LEDs to help with troubleshooting, replaceable EPROM for software upgrades, and plug-in terminal strips and RJ-12 jacks which allow for quick field installation.

Interaction with the system is through the TWLC keypad/display. A simple 4-button keypad is used to change operation mode and to navigate through the menus to view and change system parameters. A backlit LCD display supplies easy to read information about the system, including water temperatures, operation mode, which chillers are running, and other detailed information. Three small LEDs on the keypad clearly indicate Cool or Heat modes, and faults. An alarm buzzer on the keypad can also signal a fault. Additional TWLC keypads can be installed to allow remote system access.

(Continued on reverse side)

Key Benefits

- Up to 6 chiller units can be integrated into one network.
- Keypad/Display has a 4-button control and a 4-line backlit LCD display.
- Multiple keypad/displays can be used for remote access.
- Multi-unit panels come with circuit breakers for compressor and pump control.
- Chiller staging based on circulated water temperature.
- Compressor rotation to equalize run time of each unit.
- Compressor and pump time delay to prevent simultaneous starting.
- Records and logs faults and run times.
- Monitors 12 different faults.

Advanced Options

- Connect to an on-board computer or modem.
- Current transducers to monitor compressor and pump amperage.
- Seawater temperature sensors.
- Refrigerant pressure transducers.
- Loop water and seawater pressure transducers.
- Control an optional source of heat (electric immersion heater or fuel-fired boiler).
- Remote unit shutdown for load shedding.
- Fault signal output for remote alarm.

Set up and operation of the TWLC is fully automatic. It senses how many units are connected and programs the temperature staging and unit rotation of the units to pre-programmed parameters. The TWLC board has non-volatile memory so settings and recorded information are not lost even if power is interrupted. The large memory capacity allows the TWLC to record run time of the compressors and pumps, and store the fault history of each unit.

The system monitors all the inputs and will display 12 different faults based on the information received. Each fault has a specific routine that protects the unit while helping to prevent nuisance faults. Some will generate a sustained shutdown, which must be reset from the TWLC keypad.

If a fault is sensed, the fault LED on the TWLC keypad will light (and the buzzer will sound, if activated) and the specific fault will be displayed on the LCD screen. The fault signal output on the P/L boards will also be powered.

Another feature of the TWLC is that it can be connected to an on-board computer or modem to allow full remote access of the system. Custom software emulates the TWLC on the computer screen and navigation through the menus is identical to the TWLC keypad/display. If a land phone line is available, a modem can be connected and the system can be viewed and operated remotely, allowing a knowledgeable service agent to troubleshoot the system anywhere in the world.

Multi-Unit Control Panels

TWLC is available only as part of multi-unit chiller package. The custom panel will include the microprocessor boards, keypad/display, circuit breakers and relays for the compressors and pumps. Wiring from the panel to the chillers is also included. A control power transformer is included on 380-460V panels.

Because each multi-unit panel is custom built, there are many options available:

- **Spare Pump Switch** – Selector switches can be added for backup (spare) pumps.
- **Multiple Power Inputs** – Up to 3 power blocks can be installed to help divide the chiller and pump loads.
- **Auxiliary Water Heater** – If an auxiliary water heater is desired, the panel can be built with the appropriate breakers and contactors to control the heater.
- **Fault Output Relay** – A set of “dry” contacts can be installed to operate an alarm on the vessel’s monitoring system.
- **Longer Wire Harness** – The standard harness is 10 ft (3m) but longer harnesses are available, up to 30’ (9m).
- **Frame Mounted Panel** – If a framed chiller is ordered, the panel can be mounted on the frame.
- **Load Shedding** – Terminals can be provided in the panel to allow a load-shedding system to remotely shut down individual chillers.

In addition to the options above, two different upgrade packages are available for multi-unit panels:

- The Level 1 upgrade package adds current transducers for the compressors and pumps, seawater out temperature sensors in each chiller, a common seawater inlet temperature sensor, and the computer and modem adapters.
- The Level 2 package includes all items in Level 1, plus: high and low refrigerant pressure transducers for each chiller, a seawater pressure transducer (to install on the discharge of the seawater pump) and a loop water pressure transducer (to install on the inlet of the loop water pump).

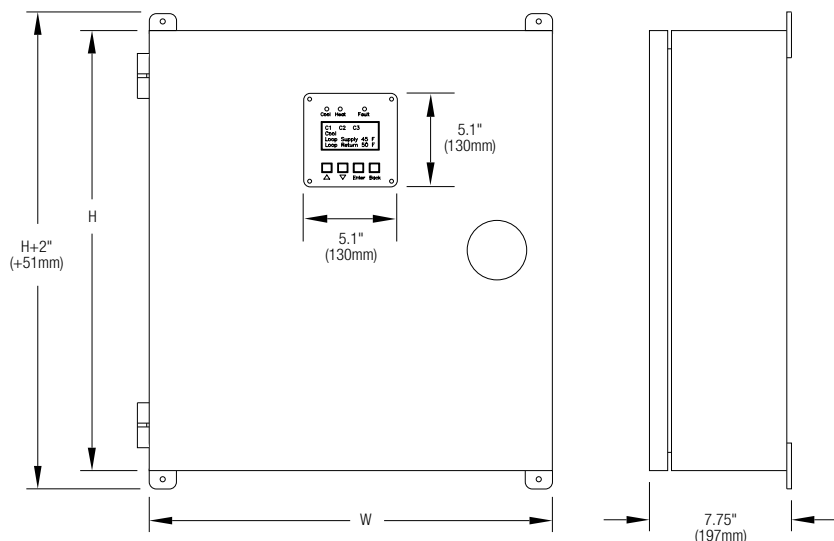

TWLC Dimensions

No. of Units	Width (in/mm)	Height (in/mm)
2 - 3	22.0/560	24.0/610
4	30.0/760	24.0/610
5	35.0/890	24.0/610

Typical dimensions for standard panels. Options such as transducers, spare pump switches, multiple power inputs, etc. might require the next larger panel size.

DOMETIC MARINE DIVISION

2000 N. Andrews Ave. Ext. I Pompano Beach, FL 33069 USA | 954-973-2477 | Fax 954-979-4414
 www.DometicUSA.com | MarineSales@DometicUSA.com

24/7 Tech Support for United States & Canada:

8:00 AM to 5:00 PM Eastern Time: 800-542-2477

After hours and weekends: 888-440-4494

International Sales & Service:

Europe & the Middle East: Call +44(0)870-330-6101

For all other areas visit our website to find your nearest distributor.



Environmentally Responsible

Dealer:

NEW!

In-Duct Breathe Easy™ Air Purifier

Stops Odors & Reduces Unhealthy Contaminants



In-Duct Breathe Easy Air Purifier

Customer Comment:

"The crew had consistent problems with sore throats and coughs. So we've gone to Dometic. We discovered the air...went from being almost heavy and saturated to being a lot lighter. It was easier to breathe...cleaner. It's fantastic."

— James Rose-Innes, First Mate, 95 ft. motor yacht
Fort Lauderdale, FL

Reduce the odors of tobacco smoke, mildew, mustiness, chemical vapors and toilets, and inhale fresher, cleaner, healthier air. The in-duct Breathe Easy Air Purifier uses innovative Photocatalytic Nano-Mesh technology with ultraviolet (UV) light to improve air quality. The UV bulb inside uses a specific frequency of light that produces no harmful ozone.

How It Works

- 1 Biological contaminants like VOCs, mold spores, bacteria, and viruses pass through the air conditioning duct and into the air purifier system.
- 2 UV light energy activates the titanium-dioxide catalyst on the surface of the nano-mesh structure. The molecules of pollutants and odors that come in contact with the catalytic nano-mesh structure are reconfigured into non-toxic elements. Vortex action maximizes air contact with the catalytic surface.
- 3 Significantly cleaner, healthier air exits the photocatalytic air purifier.

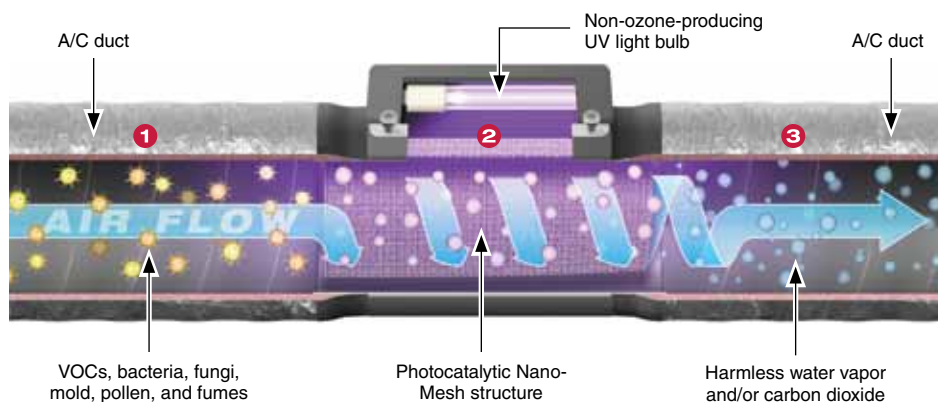

Key Benefits

- Reduces mold spores, bacteria, viruses, and fumes.
- Eliminates unpleasant odors.
- Uses an intense UV light that produces no harmful ozone.
- Enhances air quality.
- Cleaner air may lessen allergy and asthma symptoms.
- Silent operation.
- Up to 100% reduction in diesel fumes, acetone, benzene, formaldehyde, and other VOCs.
- Up to 100% reduction in bacteria, fungi, mold, and pollen.
- Photocatalytic Nano-Mesh structure is safe and powerful.
- Photocatalytic Nano-Mesh structure does not degrade under intense UV light.
- UV bulb is easy to replace.
- Tube sizes for common duct diameters.

Technical Specifications for In-Duct Breathe Easy Air Purifiers

Model	4" In-Duct Tube	5" In-Duct Tube	6" In-Duct Tube	7" In-Duct Tube	8" In-Duct Tube
Capacity ⁽¹⁾	6K BTU/hr	7K - 8K BTU/hr	10K - 12K BTU/hr	14K - 16K BTU/hr	24K BTU/hr
Volts/Hz/mA	115/60/200	115/60/200	115/60/200	115/60/250	115/60/250
	220/50/350	220/50/350	220/50/350	220/50/350	220/50/350
	230/60/200	230/60/200	230/60/200	230/60/225	230/60/225
UV Bulb Watts	12	12	12	20	20
Ø (in/mm) ⁽²⁾	4.50/114	5.50/140	6.50/165	7.50/191	8.50/216
Height (in/mm) ⁽²⁾	5.25/133	6.50/165	7.50/191	8.50/216	9.50/241
Width (in/mm) ⁽²⁾	10.50/267	10.50/267	10.50/267	13.50/343	13.50/343

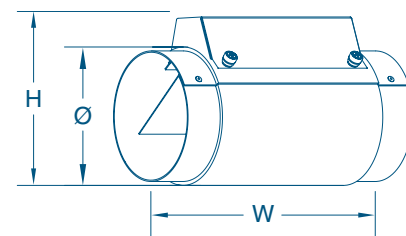

Notes:

⁽¹⁾ Purification capacity of in-duct units equals or exceeds the airflow and BTU capability of its duct size.

⁽²⁾ Dimensions are overall, including grommets, insulation, and duct rings.

Competitive Advantages

Photocatalytic Nano-Mesh Technology

- A 3-dimensional Photocatalytic Nano-Mesh structure coated with titanium-dioxide (TiO₂) provides maximum surface area for maximum destruction of airborne contaminants that come in contact with it.
- Little or no reduction in air flow because the Photocatalytic Nano-Mesh structure creates very little static pressure.
- Does not need to be cleaned, maintained, or replaced.



Dometic's Photocatalytic Nano-Mesh structure

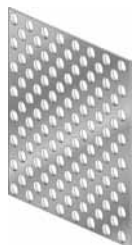

Competitor's screen structure

UV Lamps

- Sized for the dimensions of the Photocatalytic Nano-Mesh structure, a single UV bulb with dual tubes provides greater intensity and service coverage to activate more of the photocatalytic material for high-performance results.

Safe & Effective Catalyst

Titanium-dioxide is in many common products, including pigments, processed foods, toothpaste and cosmetics. It is harmless to people, pets, plants, and the environment.

Laboratory Test Results

Testing of the Breathe Easy Air Purifier performed by Environmental Diagnostics Laboratory showed up to **98% reduction** in volatile organic compounds (VOCs) and up to **100% reduction** in bacteria, fungi, mold, and pollen grains.

The Power of Photocatalytic Nano-Mesh Technology

Photocatalytic Nano-Mesh technology removes airborne contaminants that pass through the system and contact the photocatalytic surface. As air re-circulates it makes multiple passes through the system for continuously improving purification levels.

Photocatalytic air purification only occurs when airborne contaminants physically touch the catalyst. Innovative Photocatalytic Nano-Mesh technology creates a much greater contact surface for much greater results.

The Breathe Easy Air Purifier's three-dimensional Photocatalytic Nano-Mesh structure is constructed of metalized foam. This minutely intricate construction provides **2200%** more surface area for holding the molecular catalytic coating than is possible with a simple screen structure. This unique design also provides scant air resistance, so there is no noticeable decrease in air flow.

In addition, through the science of nanotechnology, the titanium-dioxide catalyst is restructured at the molecular level to have an increased number of contact surfaces. This formation puts 70% larger molecules on the contact surface and dramatically improves reactivity with contaminants.

Two Innovative Models

- **In-Duct Tube:** Air purifier tube is installed within ducting line and uses the air-conditioning system's blower to move air past the UV light and Photocatalytic Nano-Mesh structure. Available in tube sizes to fit all common duct diameters.
- **Portable:** Small and lightweight, the portable air purifier can be situated anywhere and uses an internal fan to move air past the UV light and Photocatalytic Nano-Mesh structure. It is suitable for areas up to 100 sq. ft. (9.3 sq. m.) and operates on both DC and AC voltages.

Note: The Breathe Easy Air Purifier does not fix the source of ongoing odor problems. For example, a leak that caused mold must be repaired and the mold must be removed.

DOMETIC MARINE DIVISION

2000 N. Andrews Ave. Ext. I Pompano Beach, FL 33069 USA | 954-973-2477 | Fax 954-979-4414
www.DometicUSA.com | MarineSales@DometicUSA.com

24/7 Tech Support for United States & Canada:

8:00 AM to 5:00 PM Eastern Time: 800-542-2477

After hours and weekends: 888-440-4494

International Sales & Service:

Europe & the Middle East: Call +44(0)870-330-6101

For all other areas visit our website to find your nearest distributor.



Environmentally Responsible

Dealer:

NEW!

Portable Breathe Easy™ Air Purifier

Reduces Contaminants & Stops Odors



Customer Comment:

After cleaning up a diesel fuel leak from the generator, we still had a persistent petroleum odor. I installed the portable Breathe Easy Air Purifier in the galley. A week later all odors were completely eliminated.

— John H. Thommen, Guilford, CT



Includes worldwide AC adapter with plugs and 12V DC power plug.

Reduce the odors of tobacco smoke, mildew, mustiness, chemical vapors, and toilets, and inhale fresher, cleaner, healthier air. Effective in areas up to 100 sq. ft. (9.3 sq. m.), the portable Breathe Easy Air Purifier uses innovative Photocatalytic Nano-Mesh technology with ultraviolet (UV) light to improve air quality. The UV bulb inside uses a specific frequency of light that produces no harmful ozone. The unit operates quietly and has two fan-speed settings.

How It Works

1. Non-ozone-producing UV light reduces biological contaminants like mold spores, bacteria, and viruses that pass through the air purifier system.
2. UV light energy activates the titanium-dioxide catalyst on the surface of the nano-mesh structure. The molecules of pollutants and odors that come in contact with the catalytic nano-mesh structure are reconfigured into non-toxic elements.
3. Significantly cleaner, healthier air exits the system.

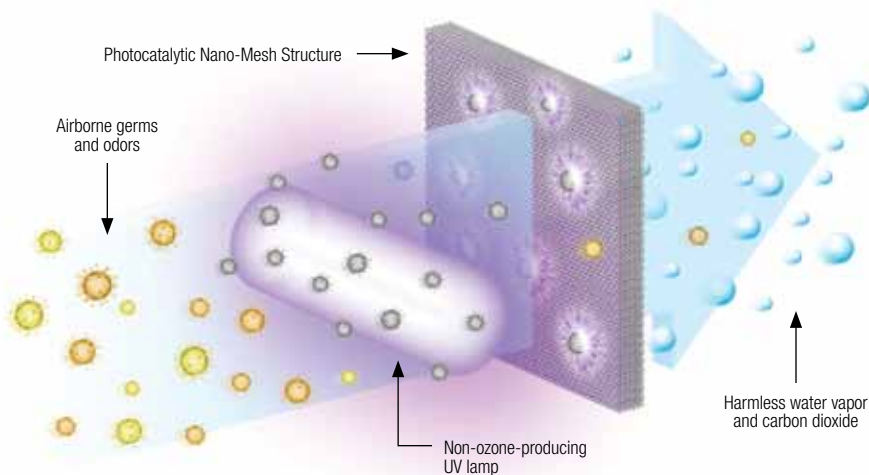

Key Benefits

- Reduces mold spores, bacteria, viruses, and fumes.
- Eliminates unpleasant odors.
- Uses an intense UV light that produces no harmful ozone.
- Enhances air quality.
- Cleaner air may lessen allergy and asthma symptoms.
- Quiet operation with two fan speeds.
- Up to 96% reduction in volatile organic compounds (VOCs).
- Up to 99% reduction in bacteria and fungi.
- Photocatalytic Nano-Mesh structure is safe and powerful.
- Photocatalytic Nano-Mesh structure does not degrade under intense UV light.
- UV bulb is easy to replace.
- Effective in areas up to 100 sq. ft. (9.3 sq. m.).
- Worldwide AC power adapter with plugs and 12V DC power plug included.

Technical Specifications for Portable Breathe Easy Air Purifier

Model	Portable
Capacity	Up to 100 sq. ft. (9.3 sq. m.)
Volts/Hz/mA	115/60/300
	220/50/200
	230/60/275
	12VDC/-/500
UV Bulb Watts	5
Height (in/mm)	1.75/45
Width (in/mm)	6.25/159
Depth (in/mm)	4.50/115

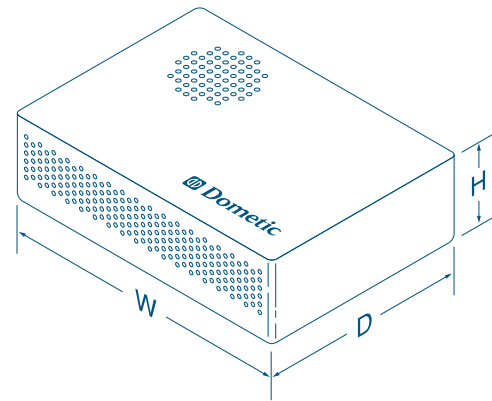

Competitive Advantages

Photocatalytic Nano-Mesh Technology

- A 3-dimensional Photocatalytic Nano-Mesh structure coated with titanium-dioxide (TiO₂) provides maximum surface area for maximum neutralization of airborne contaminants that come in contact with it.
- Little or no reduction in air flow because the Photocatalytic Nano-Mesh structure creates very little static pressure.
- Does not need to be cleaned, maintained, or replaced.



Dometic's Photocatalytic Nano-Mesh structure

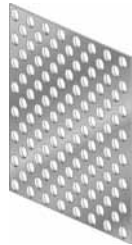

Competitor's screen structure

UV Bulbs

- Sized for the dimensions of the Photocatalytic Nano-Mesh structure, a single UV bulb with dual tubes provides greater intensity and service coverage to activate more of the photocatalytic material for high-performance results.

Safe & Effective Catalyst

Titanium-dioxide is in many common products, including pigments, processed foods, toothpaste and cosmetics. It is harmless to people, pets, plants, and the environment.

Laboratory Test Results

Independent testing of the Breathe Easy Air Purifier performed by Environmental Diagnostics Laboratory showed up to **96% reduction** in volatile organic compounds (VOCs) and up to **99% reduction** in bacteria and fungi.

The Power of Photocatalytic Nano-Mesh Technology

Photocatalytic Nano-Mesh technology removes airborne contaminants that pass through the system and contact the photocatalytic surface. As air re-circulates it makes multiple passes through the system for continuously improving purification levels.

Photocatalytic air purification only occurs when airborne contaminants physically touch the catalyst. Innovative Photocatalytic Nano-Mesh technology creates a much greater contact surface for much greater results.

The Breathe Easy Air Purifier's three-dimensional Photocatalytic Nano-Mesh structure is constructed of metalized foam. This minutely intricate construction provides 2200% more surface area for holding the molecular catalytic coating than is possible with a simple screen structure. This unique design also provides scant air resistance, so there is no noticeable decrease in air flow.

In addition, through the science of nanotechnology, the titanium-dioxide catalyst is restructured at the molecular level to have an increased number of contact surfaces. This formation puts 70% larger molecules on the contact surface and dramatically improves reactivity with contaminants.

Two Innovative Models

- **In-Line Ductable:** Air purifier ducting tube is installed within ducting line and uses the air-conditioning system's blower to move air past the UV light and Photocatalytic Nano-Mesh structure. Available in tube sizes to fit all common duct diameters.
- **Portable:** Small and lightweight, the portable air purifier can be situated anywhere and uses an internal fan to move air past the UV light and Photocatalytic Nano-Mesh structure. It is suitable for areas up to 100 sq. ft. (9.3 sq. m.) and operates on both DC and AC voltages.

Note: The Breathe Easy Air Purifier does not fix the source of ongoing odor problems. For example, a leak that caused mold must be repaired and the mold must be removed.

DOMETIC MARINE DIVISION

2000 N. Andrews Ave. Ext. I Pompano Beach, FL 33069 USA | 954-973-2477 | Fax 954-979-4414
www.DometicUSA.com | MarineSales@DometicUSA.com

24/7 Tech Support for United States & Canada:

8:00 AM to 5:00 PM Eastern Time: 800-542-2477
After hours and weekends: 888-440-4494

International Sales & Service:

Europe & the Middle East: Call +44(0)870-330-6101
For all other areas visit our website to find your nearest distributor.



Dealer:

Breathe Easy™ Air Filters

Micro-Particle, Anti-Allergenic Air Filters



Enjoy cleaner, improved air quality on your boat with Breathe Easy™ Air Filters. Breathe Easy micro-particle, anti-allergenic air filters are rated Merv 7, making them seven times more effective than ordinary air filters.

Breathe Easy Air Filters are efficient and disposable, and are available for most Dometic air conditioning systems.

Key Benefits

- Rated Merv 7: Seven times more effective than ordinary foam and slide-in mesh screen air conditioning filters at capturing airborne micro-particles.
- Capture diesel smoke, dust, lint, bilge odors, and pet dander.
- Electrostatically-charged fibers attract and retain micro-particles in the air.
- Easy installation for all types and models of air conditioners.
- Custom sizes are available.



Breathe Easy™ Air Filters are easily installed and are available for most Dometic air conditioning systems.

Filter P/N	Fits Cruisair A/C Models	Fits Marine Air A/C Models	Fits Dometic A/C Models	Width x Height	
				inches	mm
235000600	SXF5, SXF5-1, SHF5, SHF5-1, ZF5, ZF5-1	VCD5K/1, VCP5K, VCM5K, VCM5K/1, CLM5KC, CLM5KC/1	ECM5, ECD5	7-7/8 x 9	200 x 229
235000601	SXF7, SXF7-1, SHF7, SHF7-1, SXR7-1, SHR7-1, SXR10, SHR10, SXR12, SHR12	VCD7K/1, VCP7K, VCM7K, VCM7K/1, CMCD7K/1, CMCM7K, CMCM7K/1	ECM6.5, ECD6.5	9-3/8 x 10	238 x 254
235000602	SXR7, SHR7 (old style 7K), ZF3.5	CD3.5, SVCM3.5, CLM3.5	N/A	8-1/8 x 8	206 x 203
235000603	SXF10-1, SHF10-1, ZF10-1	VCD10K/1, VCM10K/1, CLM10KC/1, CMCD10K/1, CMC-M10K/1	ECM9, ECD9	10-7/8 x 10	276 x 254
235000604	SXF10, SHF10, ZF10, ZF12	VCP10K, VCM10K, CLM10KC, CLM12KC, CMCP10K, CMC-M10K	N/A	11-7/8 x 10	302 x 254
235000605	SXF12-1, SHF12-1, SXF16-1, SHF16-1, ZF12-1, SXR16, SHR16, ZF16-1, STX14, STX16, STQ14, STQ16, STH14, STH16	VCD12K/1, VCM12K/1, CLM12KC/1, CMCD12K/1, CMC-M12K/1, VCD16K/1, VCM16K/1, CLM16KC/1, CMCD16K/1, CMCM16K/1, VTD14, VTD16, VTM14, VTM16	ECM11, ECD11	10-7/8 x 12	276 x 305
235000606	SXF12, SHF12, SXF16, SHF16, SXF18, SHF18, ZF16	VCP12K, VCM12K, VCP16K, VCM16K, VCD18, CLM16KC, CMCP16K, CMCM16K	ECM15, ECD15	11-7/8 x 12	302 x 305
235000607	SXF24, SXF24-1, SHF24, SHF24-1 (special order)	VCD24K/1, VCP24K, VCM24K, VCM24K/1 (special order)	N/A	16-3/8 x 16	416 x 406
235000608	SX24, SH24 (special order)	N/A	N/A	15-1/8 x 17	384 x 432
235000638	STX6, STX8, STQ6, STQ8, STH6, STH8	VTD6, VTD8, VTM6, VTM8	N/A	8-7/8 x 10-1/4	226 x 261
235000639	STX10, STX12, STQ10, STQ12, STH10, STH12	VTD10, VTD12, VTM10, VTM12	N/A	10-7/8 x 11-1/2	276 x 293

Note to Customer: Please pay close attention to A/C models 10, 12, and 16, and whether or not they have the suffix "-1" or "/1" in the model number. Additionally, unit filters for all 5-16K models with the suffix "-1" and "/1" unit filters are interchangeable with "-2" and "/2" units.

Decide What Size You Need

Locate the data plate on the air conditioning unit and determine the model number or BTU capacity, and measure the size of the evaporator face to determine the correct filter size. Note: the evaporator is the large square corrugated metal piece situated just behind the blower.

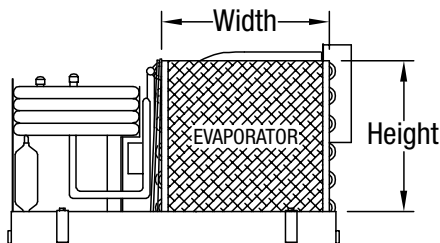

How To Install the Filter

The filter should be installed directly over the face of the evaporator, using the existing brackets on the air conditioning unit. If there are no installed brackets to hold the filter in place, use the pins contained in this package to attach the filter. Press the pins through the four corners of the filter and into the spaces between the thin metal fins on the evaporator face.

Note: These high-efficiency filters should not be used in conjunction with any other filters or screens. Make sure you remove any existing filters or screens in the return air path.

When To Replace the Filter

Because of its high efficiency in filtering air, the white filters should be changed at frequent intervals to maintain the air quality, and to avoid restricting airflow. Failure to change filters at the recommended intervals can cause the air conditioner to shut down from lack of air flow or from an icing condition.

Every 2 months – liveaboard conditions or a boat where the air conditioner runs constantly.

Every 4 months – using the boat 3 weekends of every month.

Every 6 months – using the air conditioner 1 – 2 times per month.

Please contact your Cruisair or Marine Air dealer to order air filter replacements.

DOMETIC MARINE DIVISION

2000 N. Andrews Ave. Ext. I Pompano Beach, FL 33069 USA | 954-973-2477 | Fax 954-979-4414
www.DometicUSA.com | MarineSales@DometicUSA.com

24/7 Tech Support for United States & Canada:

8:00 AM to 5:00 PM Eastern Time: 800-542-2477
After hours and weekends: 888-440-4494

International Sales & Service:

Europe & the Middle East: Call +44(0)870-330-6101
For all other areas visit our website to find your nearest distributor.



Environmentally Responsible

Dealer:

NEW!

Power Up With SmartStart™

Eliminate Startup Spikes



SmartStart™ Model
#4220040 shown

The biggest drain on your power source usually occurs when the air conditioning compressor starts. The big power surge can cause lights and other electrical appliances to flicker and falter. In severe cases, the surge can cause the boat to lose power completely.

The SmartStart™ is a unique device that smoothes out startup power demand instead of spiking it, reducing amp requirements by up to 65%. The technology uses dynamic feedback control to reduce the inrush of current by starting the compressor motor slowly. No other soft starter in the industry provides better performance.

Discover How to Save Money and Energy

Once running, an air conditioning compressor has a much lower, steady amp draw, but the initial locked-rotor amps needed to start the system can create high current surges that could adversely affect the operation of an overstrained power source.

In some situations, this gentler method of handling the power surge can mean the difference between keeping the generator you have or investing thousands of dollars in a larger generator.

For boats without a generator, the SmartStart™ may allow the option of powering an air conditioning system from an inverter.

When running on dock power, a SmartStart™ may resolve issues where the power source or connection may be weak.

Continued on reverse side

Key Benefits

- Reduces strain on the power source.
- Reduces brown-out effects at compressor start up.
- May enable an inverter to power A/C.
- May eliminate the need to upgrade your generator.
- Inexpensive.
- Small and lightweight.

Customer comment:

"The generator's control circuit would trip and stop the generator due to the inrush of the Emiko's heat pump. The SmartStart reduced that inrush of current so the generator would continue to run."

We started with an inrush of 77 amps and finished with an inrush of only 20 amps. [The SmartStart] is a great solution to our problem."

M/V Emiko, 37 ft. Nordic Tug
Mr. John Poole, Poole Refrigeration Service
Alameda, CA

Not only does the SmartStart™ ease strain on the power source, it's also less stressful for the compressor itself since it starts more gently. Additionally, it provides valuable protection by shutting down the compressor if the power source or the connection to the compressor is briefly interrupted, then it reattempts a soft start after a three-minute delay.

Little Package

All this power comes in a surprisingly small package. At only 5 x 3 x 2 in. (127 x 76 x 51 mm), the SmartStart™ takes up little space and weighs only 15 oz. (0.43 kg.). The SmartStart™ is wired directly into the air-conditioning system's electrical box.

Technical Specifications for SmartStart™

Model	Voltage (volts) / Frequency (Hz)	Supported Compressor Capacity Range (BTUs)
4220040	115/60	5K-18K
4220043	208-240/50-60	12K-30K
4220044	208-240/50-60	36K-60K
SmartStart™ Accessories		
4220045	Optional Mounting Tray	

Notes:

- Maximum continuous current for all models: 32 Amps.
- Typical start surge reduction as compared to compressor locked-rotor amperage (LRA): 65%.

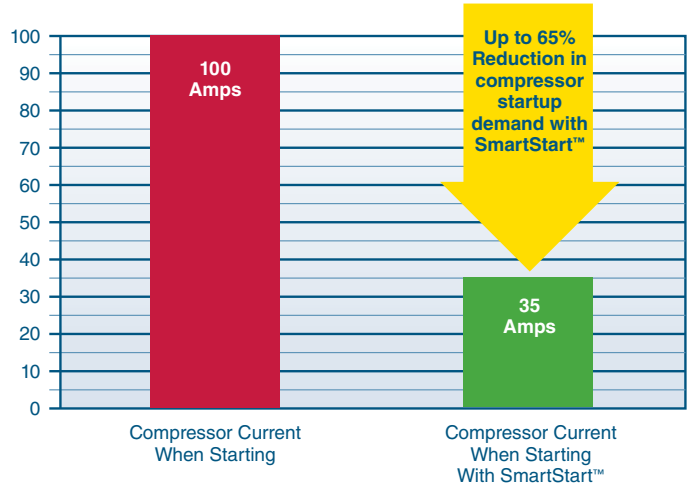

SmartStart™ Wiring Diagram

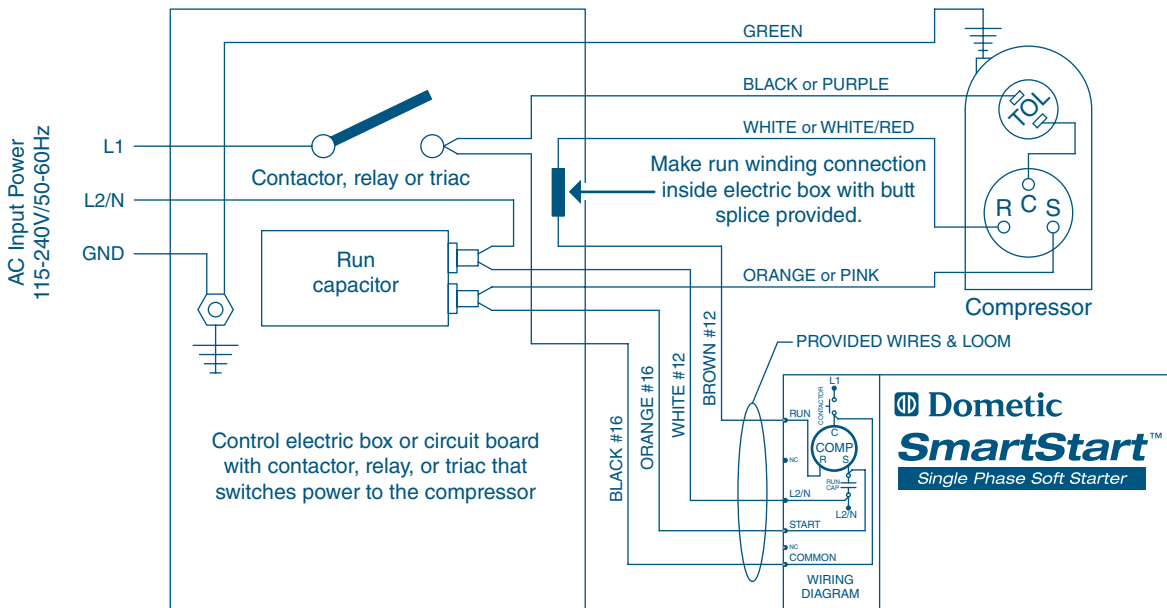

DOMETIC MARINE DIVISION

2000 N. Andrews Ave. Ext. I Pompano Beach, FL 33069 USA | 954-973-2477 | Fax 954-979-4414
www.DometicUSA.com | MarineSales@DometicUSA.com

24/7 Tech Support for United States & Canada:

8:00 AM to 5:00 PM Eastern Time: 800-542-2477
After hours and weekends: 888-440-4494

International Sales & Service:

Europe & the Middle East: Call +44(0)870-330-6101
For all other areas visit our website to find your nearest distributor.



Environmentally Responsible

Dealer:

March Marine Pumps

Centrifugal Seawater Pumps for Marine A/C



Clockwise from left:
LC-2CP-MD, AC-5CP-MD,
and LC-3CP-MD

March centrifugal pumps are an excellent choice for providing seawater circulation for marine air conditioning systems. The proven magnetic drive eliminates the troublesome mechanical shaft seal.

There is no seal wear, power-robbing friction, or leakage through the seal. The impeller and drive magnets are strong, permanent ceramic types, which prevent slippage, ensuring that full motor power is converted into pumping power.

Centrifugal pumps require a flooded inlet and should be mounted below the waterline. However, an optional priming reservoir is available for applications where the pump must be mounted above the waterline (2.0'/0.6 m max.).

“LC” models have liquid-cooled motors and can be run in open air or submerged. “AC” models have air-cooled, open drip-proof motors and must be in a dry environment.

Replacement parts for March pumps are available through Dometic.

Key Benefits

- Magnetic-drive impeller means no seal to wear, leak, or repair.
- Efficient motor with low power consumption.
- Includes a marine-grade base.
- 115V and 230V models.
- Liquid-cooled (submersible) and air-cooled motors available.
- All components in contact with water are plastic, ceramic, or stainless steel.
- 6' (1.9 m) power cord standard.
- Optional priming reservoir available for above-waterline applications.
- 1-year warranty on parts.

Technical Specifications for March Centrifugal Seawater Pumps

Model	Max. flow (gpm)	Max. head (ft/m)	Connections		Motor HP	Volts	Freq. ⁽¹⁾	Amps	Weight (lbs/kg)	Motor type ⁽²⁾	Wet end assembly
			Inlet	Outlet							
LC-2CP-MD 115V	5.0	13/3.9	3/4" MPT	1/4" MPT	1/35	115V	50/60Hz	1.00	5.0/2.3	TE/SUB	A-507P
LC-2CP-MD 230V	5.0	13/3.9	3/4" MPT	1/4" MPT	1/35	230V	50/60Hz	0.53	5.0/2.3	TE/SUB	A-507P
LC-3CP-MD 115V	8.5	19/5.8	3/4" FPT	1/2" MPT	1/20	115V	60Hz	2.00	9.0/4.1	TE/SUB	A-508P
LC-3CP-MD 230V	8.5	19/5.8	3/4" FPT	1/2" MPT	1/20	230V	60HZ	1.00	9.0/4.1	TE/SUB	A-508P
LC-5C-MD 115V	14.5	27/8.2	1" FPT	1/2" MPT	1/8	115V	50/60HZ	2.20	15.5/7.0	TE/SUB	A-506LC
LC-5C-MD 230V	14.5	27/8.2	1" FPT	1/2" MPT	1/8	230V	50/60HZ	1.10	15.5/7.0	TE/SUB	A-506LC
AC-5C-MD 115V	17.0	27/8.2	1" FPT	1/2" MPT	1/8	115V	50/60HZ	2.10	10.0/4.5	OD	A-506
AC-5C-MD 230V	17.0	27/8.2	1" FPT	1/2" MPT	1/8	230V	50/60HZ	1.00	10.0/4.5	OD	A-506

Notes:

⁽¹⁾ Standard 50/60Hz pumps may be operated at 50Hz and reduced voltages. However, there will be a 17% reduction in flow rate and as much as a 30% drop in head in that application. The model LC-3CP-MD pump is 60Hz only and may not be operated at 50Hz.

⁽²⁾ The TE/SUB is a totally-enclosed, liquid-cooled motor and can be operated in the open air or submerged. The OD is an open drip-proof, air-cooled motor and must be kept dry.

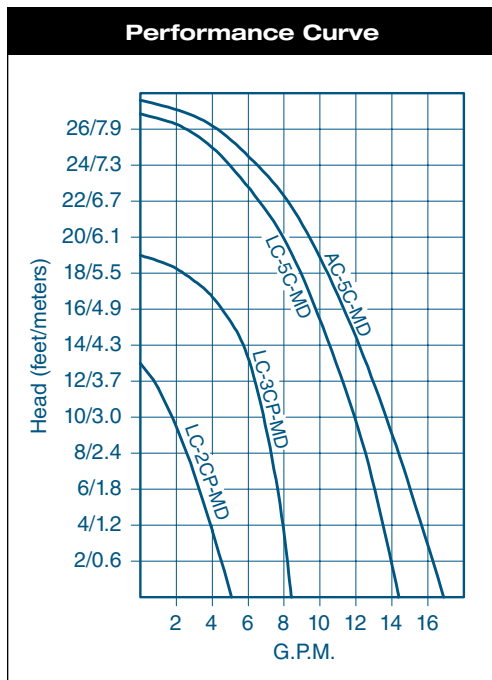

DOMETIC MARINE DIVISION

2000 N. Andrews Ave. Ext. I Pompano Beach, FL 33069 USA | 954-973-2477 | Fax 954-979-4414
 www.DometicUSA.com | MarineSales@DometicUSA.com

24/7 Tech Support for United States & Canada:

8:00 AM to 5:00 PM Eastern Time: 800-542-2477
 After hours and weekends: 888-440-4494

International Sales & Service:

Europe & the Middle East: Call +44(0)870-330-6101
 For all other areas visit our website to find your nearest distributor.



Environmentally Responsible

Dealer:

Seawater Pumps

Reliable & Heavy-duty Centrifugal Pumps



Photo courtesy of Cruisers Yachts



P711 and PML500CL shown

Marine Air specifies reliable, heavy-duty centrifugal pumps to provide a steady flow of cooling water through the air conditioning system.

The glass-reinforced polypropylene head pumps have magnetic drive impellers, and are available with submersible or air-cooled motors. Larger pumps have bronze heads with mechanical seals, and air-cooled, drip-proof motors. A wide range of pumps and motors are available for use in different power environments.

Centrifugal pumps must be mounted below the water line. Self-priming pumps are also available for above-water-line applications. A scoop type through-hull and a seawater strainer are recommended for proper operation.

When more than one air conditioning unit is served by a single pump, a separate pump relay is used. To complete the installation, Marine Air can also supply water manifolds, hose, and fittings.

Key Benefits

- High-capacity centrifugal pumps..
- Quiet operation.
- Minimum maintenance.
- Single-phase motors have built-in thermal overload and ignition protection.
- Three-phase, ignition-protected motors.
- Seawater grade construction, with glass filled polypropylene or bronze pump heads.
- Submersible or air-cooled motors.
- Vibration isolation mounts standard.
- High-head pressure models available.
- Self-priming pumps available.
- All units meet or exceed applicable ABYC and U.S. Coast Guard regulations, CE Directives and general Air Conditioning and Refrigeration (ARI) standards.

Technical Specifications for Seawater Pumps

Model	Volts/Hz/Phase	Amps	IP ⁽²⁾	HP	GPM ⁽³⁾ @ Feet of Head ⁽⁴⁾	Capacity BTU/hr ⁽⁵⁾	Inlet X Outlet	Height (in/mm)	Width (in/mm)	Length (in/mm)	Net Weight (lb/kg)
P800 12VDC	12 VDC	1.0	N	1/150	2 @ 7'	6,000	3/8" FPT X 3/8" OD	3.75/95	2.81/71	5.13/130	1.2/0.5
PMLL150-12V DC	12 VDC	1.0	N	1/150	2 @ 7'	6,000	3/8" FPT X 3/2" HB	3.0/76	2.75/70	4.5/114	1.0/0.5
PMLL150-24V DC	24 VDC	0.5	N	1/150	2 @ 7'	6,000	3/8" FPT X 3/2" HB	3.0/76	2.75/70	4.5/114	1.0/0.5
PML250	115/60/1	1.0	Y	1/35	3 @ 7'	12,000	3/4" MPT X 1/4" MPT	4.70/119	5.60/142	6.20/157	5.0/2.3
PML250C	230/50-60/1	0.5	Y	1/35	3 @ 7'	12,000	3/4" MPT X 1/4" MPT	4.70/119	5.60/142	6.20/157	5.0/2.3
P900-12V DC	12 VDC	3.8	N	1/25	3 @ 6.5'	12,000	1/2" FPT X 1/2" HB	4.5/114	3.5/89	9.0/229	4.5/2.0
P900-24V DC	24 VDC	1.9	N	1/25	3 @ 6.5'	12,000	1/2" FPT X 1/2" HB	4.5/114	3.5/89	9.0/229	4.5/2.0
PML500L	115/60/1	2.0	Y	1/20	6 @ 14'	24,000	3/4" FPT X 1/2" MPT	5.60/142	5.60/142	7.40/188	9.0/4.1
PML500CL	230/50-60/1	1.0	Y	1/20	6 @ 14'	24,000	3/4" FPT X 1/2" MPT	5.60/142	5.60/142	7.40/188	9.0/4.1
PML500CK	220/50/1	0.8	Y	1/20	6 @ 9.5'	20,000	3/4" FPT X 1/2" MPT	5.60/142	5.60/142	7.40/188	9.0/4.1
PMA500	115/60/1	2.4	Y	1/12	7.5 @ 14'	30,000	3/4" FPT X 1/2" MPT	5.0/127	4.0/102	9.0/229	7.0/3.2
PMA500C	230/50-60/1	1.2	Y	1/12	7.5 @ 14'	30,000	3/4" FPT X 1/2" MPT	5.0/127	4.0/102	9.0/229	7.0/3.2
PMA500CK	220/50/1	0.9	Y	1/12	5 @ 11'	20,000	3/4" FPT X 1/2" MPT	5.0/127	4.0/102	9.0/229	7.0/3.2
PMA1000	115/60/1	2.1	Y	1/8	12 @ 14'	48,000	1" FPT X 1/2" MPT	6.25/159	4.50/114	9.10/231	10/4.5
PMA1000C	230/50-60/1	1.0	Y	1/8	12 @ 14'	48,000	1" FPT X 1/2" MPT	6.25/159	4.50/114	9.10/231	10/4.5
P100	115/60/1	7.2	Y	1/3	15 @ 16'	60,000	1.25" FPT X 1" FPT	8.50/216	8.50/216	13.9/353	25/11
P100Z	230/50-60/1	3.6	Y	1/3	15 @ 16'	60,000	1.25" FPT X 1" FPT	8.50/216	8.50/216	13.9/353	25/11
P120	115/60/1	4.9	Y	1/3	21 @ 25'	84,000	1.25" FPT X 1" FPT	8.50/216	8.50/216	13.9/353	25/11
P120Z	230/50-60/1	3.5	Y	1/3	21 @ 25'	84,000	1.25" FPT X 1" FPT	8.50/216	8.50/216	13.9/353	25/11
P700	115/60/1	7.2	Y	1/3	32 @ 21'	128,000	1.25" FPT X 1" FPT	8.50/216	8.50/216	13.9/353	26/12
P700Z	230/50-60/1	3.6	Y	1/3	32 @ 21'	128,000	1.25" FPT X 1" FPT	8.50/216	8.50/216	13.9/353	26/12
P110Z-3PH	230/50-60/3	2.8	Y	1/2	18 @ 20'	72,000	1.25" FPT X 1" FPT	8.0/203	7.50/191	15.40/391	25/11
P110-460/3PH	460/60/3	1.4	Y	1/2	18 @ 20'	72,000	1.25" FPT X 1" FPT	8.0/203	7.50/191	15.40/391	25/11
P110-380/3PH	380/50/3	1.7	Y	1/2	15 @ 15'	60,000	1.25" FPT X 1" FPT	8.0/203	7.50/191	15.40/391	25/11
P700Z-3PH	230/50-60/3	2.8	Y	1/2	32 @ 32'	128,000	1.25" FPT X 1" FPT	8.0/203	7.50/191	15.40/391	30/14
P700-460/3PH	460/50-60/3	1.4	Y	1/2	32 @ 32'	128,000	1.25" FPT X 1" FPT	8.0/203	7.50/191	15.40/391	30/14
P700Z50-3PH	220/50/3	2.9	Y	1/2	32 @ 21'	128,000	1.25" FPT X 1" FPT	8.0/203	7.50/191	15.40/391	30/14
P700-380/3PH	380/50/3	1.7	Y	1/2	32 @ 21'	128,000	1.25" FPT X 1" FPT	8.0/203	7.50/191	15.40/391	30/14
P710	115/50-60/1	9.8	N	1/2	43 @ 32'	172,000	1.50" FPT X 1.50" FPT	9.40/239	7.50/191	15.40/391	34/15
P710Z	230/50-60/1	4.9	N	1/2	43 @ 32'	172,000	1.50" FPT X 1.50" FPT	9.40/239	7.50/191	15.40/391	34/15
P710Z-3PH	230/60/3	2.2	Y	1/2	43 @ 32'	172,000	1.50" FPT X 1.50" FPT	9.40/239	7.50/191	15.40/391	34/15
P710-460/3PH	460/60/3	1.1	Y	1/2	43 @ 32'	172,000	1.50" FPT X 1.50" FPT	9.40/239	7.50/191	15.40/391	34/15
P710Z50	220/50/1	7.2	N	3/4	43 @ 30'	172,000	1.50" FPT X 1.50" FPT	9.40/239	7.50/191	15.40/391	34/15
P710Z50-3PH	380/50/3	3.3	Y	3/4	43 @ 30'	172,000	1.50" FPT X 1.50" FPT	9.40/239	7.50/191	15.40/391	34/15
P710-380/3PH	380/50/3	1.9	Y	3/4	43 @ 30'	172,000	1.50" FPT X 1.50" FPT	9.40/239	7.50/191	15.40/391	34/15
P711	115/50-60/1	16.0	N	1	54 @ 42'	216,000	1.50" FPT X 1.50" FPT	9.40/239	7.50/191	15.40/391	37/17
P711Z	230/50-60/1	8.0	N	1	54 @ 42'	216,000	1.50" FPT X 1.50" FPT	9.40/239	7.50/191	15.40/391	37/17
P711Z-3PH	230/60/3	4.2	Y	1	54 @ 42'	216,000	1.50" FPT X 1.50" FPT	9.40/239	7.50/191	15.40/391	37/17
P711-460/3PH	460/60/3	2.1	Y	1	54 @ 42'	216,000	1.50" FPT X 1.50" FPT	9.40/239	7.50/191	15.40/391	37/17
P711Z50-3PH	220/50/3	4.4	Y	1	54 @ 44'	216,000	1.50" FPT X 1.50" FPT	9.40/239	7.50/191	15.40/391	37/17
P711-380/3PH	380/50/3	2.5	Y	1	54 @ 44'	216,000	1.50" FPT X 1.50" FPT	9.40/239	7.50/191	15.40/391	37/17
P711Z 1.5HP	230/60/1	10.0	N	1.5	60 @ 45'	240,000	1.50" FPT X 1.50" FPT	9.40/239	7.50/191	15.40/391	49/22
P711Z50 1.5HP	220/50/1	10.5	N	1.5	60 @ 45'	240,000	1.50" FPT X 1.50" FPT	9.40/239	7.50/191	15.40/391	49/22

Notes:

- (1) Electrical and mechanical specifications for 50-60Hz pumps are rated at 60Hz. Operating a 50-60Hz pump at 50Hz will reduce the pump head by 30% and the GPM by 17%. Do not operate 60Hz only pumps at 50Hz.
- (2) Ignition protected.
- (3) GPM flow is rated at indicated pump head.
- (4) Head calculation required for system is dependent on number and size of unit(s), length of hose, use of 90° elbows and the height of the unit(s) above the pump. Please refer to the Marine Air Systems' pump sizing guide or consult the Applications department.
- (5) Capacities given are determined using an average of 3 GPM per ton (12,000 BTU/Hr) at given GPM and head, and are rated for direct expansion (DX) AC systems only.

Contact the applications department for pumps larger than P711.

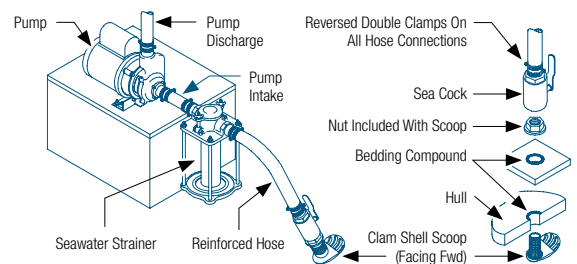

DOMETIC MARINE DIVISION

2000 N. Andrews Ave. Ext. I Pompano Beach, FL 33069 USA | 954-973-2477 | Fax 954-979-4414
 www.DometicUSA.com | MarineSales@DometicUSA.com

24/7 Tech Support for United States & Canada:

8:00 AM to 5:00 PM Eastern Time: 800-542-2477
 After hours and weekends: 888-440-4494

International Sales & Service:

Europe & the Middle East: Call +44(0)870-330-6101
 For all other areas visit our website to find your nearest distributor.



Environmentally Responsible

Dealer:

Pilot House Defroster

With Individual Ducts for Each Pane of Glass



PHDCM1.5Z4 shown

The Defroster is designed to remove any moisture or condensation that may form on the inside of a windshield.

In order to accommodate the wide range of styles and number of glass areas in yachts, the Defroster incorporates individual ducts dedicated to each pane so that all surface areas are treated.

This unit will operate in two modes: fan only supplies ambient cabin air to the windshield for those times when simple ventilation is desired; and fan with thermostatically controlled electric heat that takes cabin air and raises the temperature through the use of finned heating elements mounted in the Defroster chamber.

The unit is typically mounted under the coaming area of the pilot house.

Key Benefits

- Custom configuration for up to six duct ring outlets.
- May be mounted horizontally, vertically, flat or on edge.
- Two modes of operation: defrost or fan only.
- Constructed of lightweight marine grade aluminum.
- Tapered duct housing permits easy mounting and installation of ducting.
- Slimline style fits easily in overhead applications or under pilot house coamings.
- Two part epoxy polyurethane paint resists chipping and corrosion.
- Replaceable filter assembly in back of machine.
- Quiet, efficient squirrel cage fan for long service life.
- All units meet or exceed applicable ABYC and U.S. Coast Guard regulations, CE Directives and general Air Conditioning and Refrigeration Industry (ARI) standards.

Technical Specifications for Defroster

Model	PHDCM1.5
Capacity ⁽¹⁾ – Fan (CFM)	305
Capacity(1) – Heat (BTU/hr)	5,120
Voltage (VAC)	230
Full Load Amps (FLA) – Fan	0.83
Full Load Amps (FLA) – Heat	6.50
Kilo-Volt-Amps (KVA)	1.69
Max. Circuit Breaker	10.00
Min. Circuit Ampacity	9.00
Width (in/mm)	18.00/457
Height (in/mm)	9.50/241
Length (in/mm)	29.13/714
Net Weight (lb/kg)	23.0/10.4
Ship Weight (lb/kg)	28.0/12.7

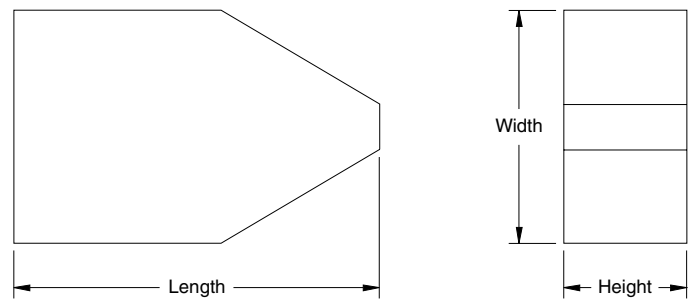

Notes:

⁽¹⁾ Ratings at 60Hz. 50Hz operation will be diminished by 17%.

Typical Installation of Defroster

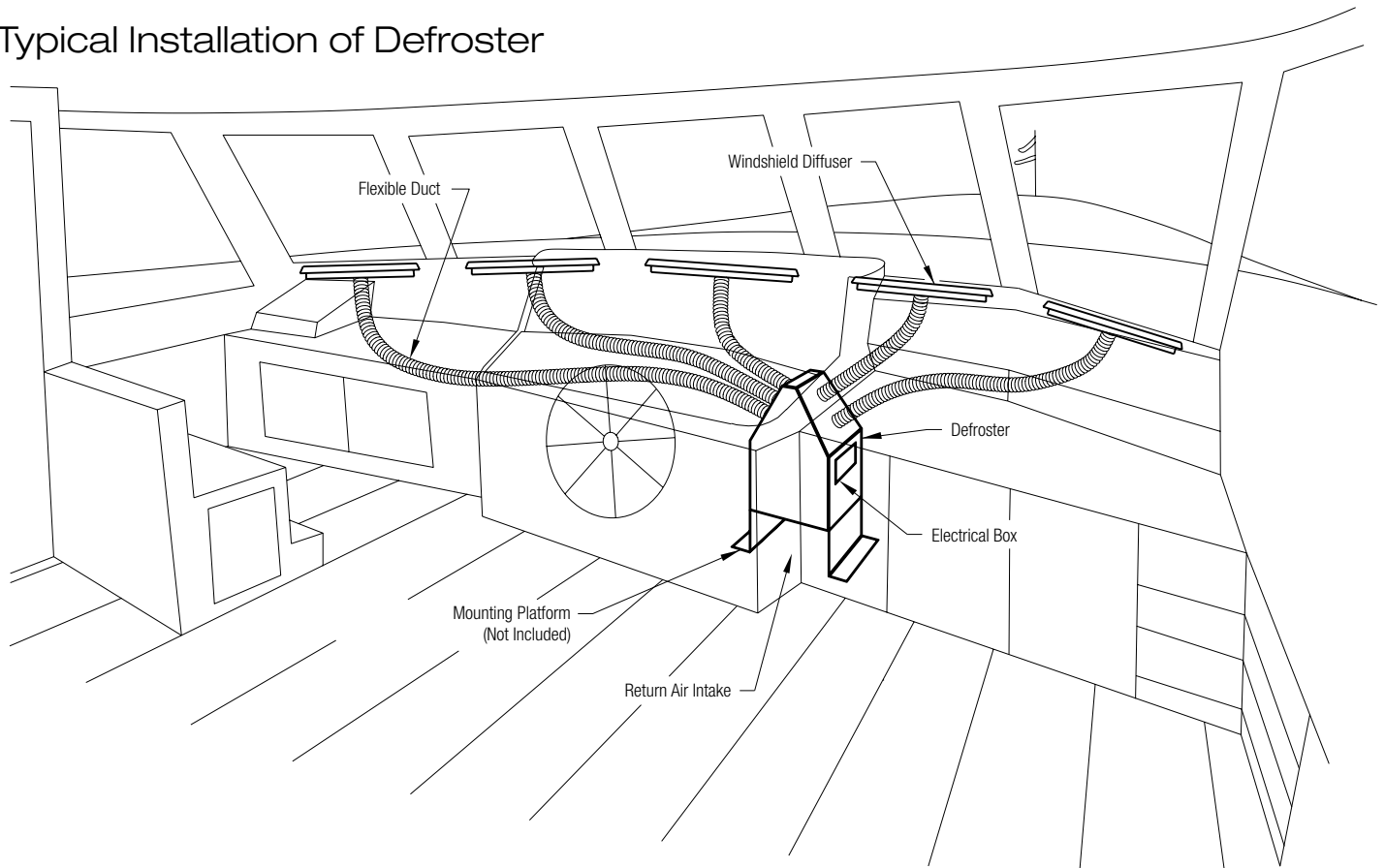

DOMETIC MARINE DIVISION

2000 N. Andrews Ave. Ext. I Pompano Beach, FL 33069 USA | 954-973-2477 | Fax 954-979-4414
 www.DometicUSA.com | MarineSales@DometicUSA.com

24/7 Tech Support for United States & Canada:

8:00 AM to 5:00 PM Eastern Time: 800-542-2477
 After hours and weekends: 888-440-4494

International Sales & Service:

Europe & the Middle East: Call +44(0)870-330-6101
 For all other areas visit our website to find your nearest distributor.



Environmentally
Responsible

Dealer:

Variable Frequency Drive

For Chilled Water A/C Compressors



VFD SQD312

A Variable Frequency Drive (VFD) completely eliminates the large starting inrush current of the compressor by ramping up voltage and frequency in a controlled time period. This allows running on limited dockside power, and also protects the generator from overload.

In addition to eliminating inrush, the VFD will also run a 60Hz rated compressor at 60Hz even when input power is 50Hz, which allows full BTU capacity performance (230V only). The drive also protects the compressor by monitoring input voltage and output current, and will shut down if a problem is detected. On 208/230V systems, the VFD can “convert” single-phase input power to 3-phase output; however, the VFD current capacity must be derated (see table on second page).

The VFD unit produces a modified sine wave output for smooth acceleration and running, with precise frequency resolution. It is designed to operate in extreme environments, such as an engine room. However, the enclosure is ventilated, and must be kept dry. Any direct water contact can damage the unit.

Built-in noise filters are standard and the VFD is CE approved. The Schneider Electric Altivar 312 VFDs incorporate a class A EMC filter into their design. This helps prevent high frequency noise from affecting the AC power supply to which the drives are connected. If you have an application or a power system that requires even lower noise emission, then we recommend you purchase the class B EMC filters specifically designed to fit with the entire family of Altivar 312 VFDs. To reduce the harmonic distortion caused by the VFD, we recommend you purchase a line reactor sized appropriately for the particular VFD.

An LED display allows the user to monitor operation and faults. The VFD is pre-programmed from the factory and no further setup is required. Power cables are available through special order.

How to choose the right size Variable Frequency Drive:

- Chiller compressor must be 3 phase and each compressor requires a dedicated VFD.
- Multiply the chiller's reverse cycle amps by 1.10 (10% safety factor).
- Choose the VFD from the Comp Voltage and Max AMP Rating columns (in the table on the following page) depending on compressor voltage and the phase of the input power supply, respectively.

Key Benefits

- Eliminates compressor start inrush current.
- 208/230V 3 phase output, with 1-phase or 3-phase input.
- Full 60Hz capacity even at 50Hz input (230V only).
- Low electronic noise, CE approved.
- 380/480V 3-phase models available.

Technical Specifications for Variable Frequency Drives

Model	Reference Number	Comp Voltage	Max AMP Rating		Dimensions (in/mm)			Weight (lb/kg)
			3Ph Input	1Ph Input	Height	Width	Depth	
VFD SQD17.5A230V	4251104	208-230V ⁽¹⁾	17.5	10.1	7.2/184	5.5/140	5.9/150	5.2/2.4
VFD SQD27.5A230V	4251105	208-230V ⁽¹⁾	27.5	15.9	9.1/232	7.1/180	6.7/170	10.4/4.7
VFD SQD33A230V	4251106	208-230V ⁽¹⁾	33.0	19.1	9.1/232	7.1/180	6.7/170	10.4/4.7
VFD SQD54A230V	4251110	208-230V ⁽¹⁾	54.0	31.2	13.0/330	9.7/245	7.5/190	19.9/9.0
VFD SQD66A230V	4251111	208-230V ⁽¹⁾	66.0	38.1	13.0/330	9.7/245	7.5/190	19.9/9.0
VFD SQD9.5A460V	4251108	380-460V ⁽²⁾	9.5	N/A	7.2/184	5.5/14	5.9/150	5.2/2.4
VFD SQD13.4A460V	4251112	380-460V ⁽²⁾	14.3	N/A	9.1/232	7.1/180	6.7/170	10.4/4.7
VFD SQD17A460V	4251202	380-460V ⁽²⁾	17.0	N/A	9.1/232	7.1/180	6.7/170	10.4/4.7
VFD SQD27.7A460V	4251109	380-460V ⁽²⁾	27.7	N/A	13.0/330	9.7/245	7.5/190	19.9/9.0
VFD SQD33A460V	4251201	380-460V ⁽²⁾	33.0	N/A	13.0/330	9.7/245	7.5/190	19.9/9.0

Notes:

⁽¹⁾ 208-230V VFDs will produce a 60Hz output even with 50Hz input. This allows 60Hz compressors to produce full BTU capacity in 50Hz systems.

⁽²⁾ High voltage (380-480V) VFDs can be used at 380-420V 50Hz, or 440-480V 60Hz. At these higher voltages the VFD output frequency should be the same as the input.

For programmed VFDs, please call your sales representative with the reference number and programming information (output voltage, input phase, and output frequency).

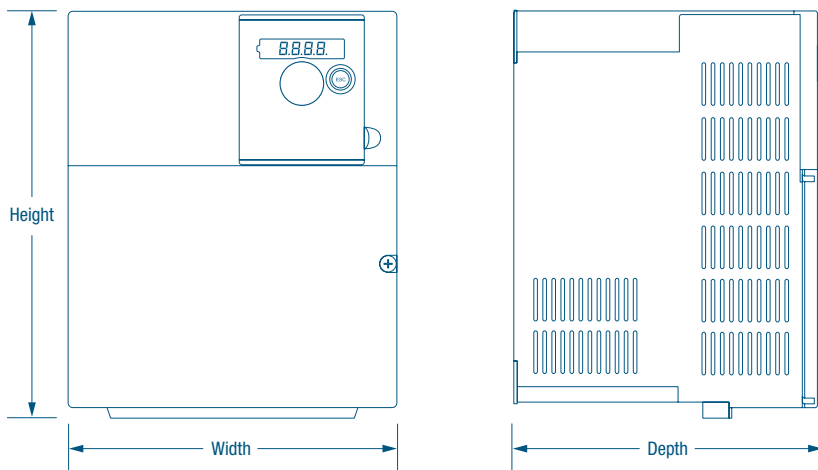

DOMETIC MARINE DIVISION

2000 N. Andrews Ave. Ext. I Pompano Beach, FL 33069 USA | 954-973-2477 | Fax 954-979-4414
 www.DometicUSA.com | MarineSales@DometicUSA.com

24/7 Tech Support for United States & Canada:

8:00 AM to 5:00 PM Eastern Time: 800-542-2477

After hours and weekends: 888-440-4494

International Sales & Service:

Europe & the Middle East: Call +44(0)870-330-6101

For all other areas visit our website to find your nearest distributor.



Environmentally Responsible

Dealer:

Pump Packages for Chillers

Convenient Solutions for Simpler Installations



P700 Centrifugal
Pump Package

Pump packages reduce the installation time of chilled-water systems by combining several necessary components in one convenient package. The packages include a chilled-water pump, expansion tank, pump drain pan, dual-scale (psi/kPa) pressure gauge, and fill assembly. The fill assembly includes a hose connection, ball valve, and pressure-reducing valve.

The cushion of air in the expansion tank allows the water to expand and contract with temperature fluctuations. This relieves pressure that might otherwise result in leaks.

The latest design includes a bladder-style expansion tank. Without the bladder, air in the expansion tank would gradually dissolve into the water and be bled off. Eventually, the protective cushion of air would be gone.

The pressure gauge is connected to an inlet pipe on the pump for the most accurate reading of system return water pressure.

Key Benefits

- Convenient packaging of multiple essential components simplifies installation.
- Expansion tank protects against thermal expansion.
- Bladder-style expansion tank protects against loss of air cushion.
- Dual-scale pressure gauge is convenient for US and international customers.
- Pressure gauge connected to inlet pipe gives most accurate reading.

Technical Specifications for Pump Packages

Model	PMA1000	PMA1000C	PMA1000CK	P120	P120Z		P700	P700Z	
Voltage (V/Hz/Phase)	115/60/1	230/60/1	240/50/1	115/60/1	230/50/1	230/60/1	115/60/1	230/50/1	230/60/1
Amps (FLA)	2.1	1.0	1.1	4.9	3.5	3.5	7.2	3.6	3.6
Recommended Applications: Total Air Handler Capacity (BTU/hr)	16-23	16-23	16	24-48	17-23	24-48	49-120	24-84	49-120
Height (in/mm)	9.2/233	9.2/233	9.2/233	9.2/233	9.5/241	9.5/241	9.5/241	9.5/241	9.5/241
Pan Width, W1 (in/mm)	11.7/297	11.7/297	11.7/297	11.7/297	15.4/391	15.4/391	15.4/391	15.4/391	15.4/391
Overall Width, W2 (in/mm)	12.9/327	12.9/327	12.9/327	12.9/327	17.1/434	17.1/434	17.1/434	17.1/434	17.1/434
Depth, D (in/mm)	18/457	18/457	18/457	18/457	18/457	18/457	18/457	18/457	18/457
Chilled Water "in" connections, female NPT	1" female	1" female	1" female	1.25" female	1.25" female	1.25" female	1.25" female	1.25" female	1.25" female
Chilled Water "out" connections, NPT	1/2" male	1/2" male	1/2" male	1" female	1" female	1" female	1" female	1" female	1" female
Net Weight, (lbs/kg)	33/14	33/14	33/14	48/21	48/21	48/21	49/22	49/22	49/22
Gross Weight, (lbs/kg)	47/21	47/21	47/21	62/28	62/28	62/28	62/28	62/28	62/28

Notes:

- Dimensions are ± 0.125 inches.

Safety note:

- Pump packages do NOT include backflow preventers. If the chilled-water fill assembly might be supplied by a potable water supply, then a reduced pressure zone (RPZ) backflow preventer should be installed between the fill assembly and the potable water supply to prevent contamination of the potable water.

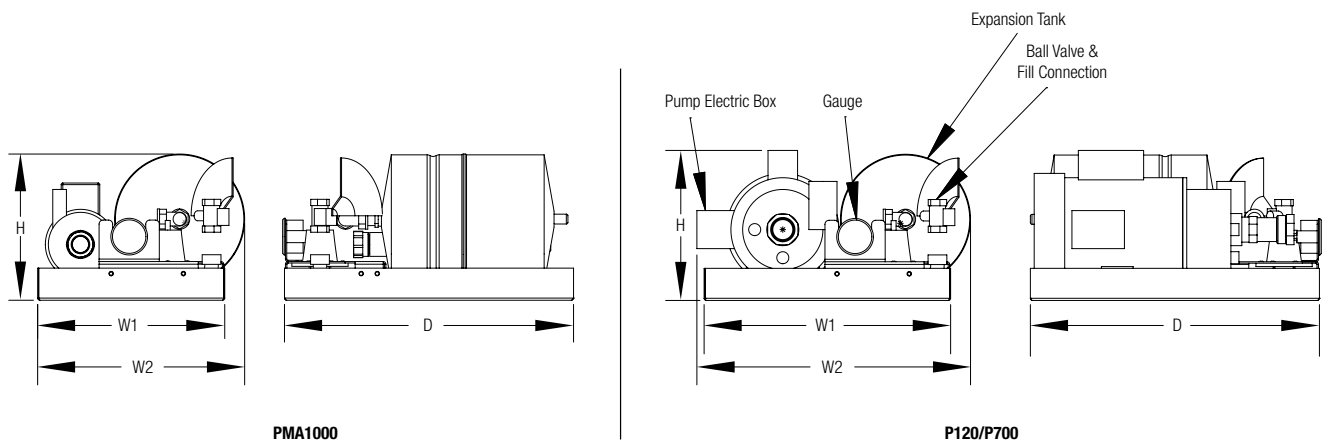

DOMETIC MARINE DIVISION

2000 N. Andrews Ave. Ext. I Pompano Beach, FL 33069 USA | 954-973-2477 | Fax 954-979-4414
 www.DometicUSA.com | MarineSales@DometicUSA.com

24/7 Tech Support for United States & Canada:

8:00 AM to 5:00 PM Eastern Time: 800-542-2477
 After hours and weekends: 888-440-4494

International Sales & Service:

Europe & the Middle East: Call +44(0)870-330-6101
 For all other areas visit our website to find your nearest distributor.



Environmentally Responsible

Dealer:

Discharge & Return Air Grilles

Aluminum, Wood, & Plastic Styles



Assorted aluminum, wood, and plastic grilles shown



Marine Air discharge and return air grilles are available in a wide assortment of dimensions, styles, and materials to blend with any yacht's interior.

The vanes of discharge grilles are secured in nylon bushings for easy dependable positioning. RA-type return air grilles have one row of fixed vanes. Wood return air grilles have a lint screen which can be removed for cleaning.

Round plastic discharge grilles are also offered in several colors with and without shut-off dampers.

Micro-Particle Anti-Allergenic air filters, designed to capture diesel smoke, dust, lint, bilge odors, and pet dander, are available for Marine Air A/C systems. These filters mount to the unit's evaporator coil and are eight times more efficient than standard filters. Due to the high efficiency of these new filters, they should be inspected and replaced at frequent intervals. When using a filter on the unit, do not also have a filter on the grille, as that would cause too much restriction of the airflow.

Key Benefits

- Large selection and variety of grilles
- Standard and custom materials complement all yacht interiors.
- Custom sizes available for any application.

Wood Frame Grilles

- Pop out louver panels with return air grilles have easy-to-clean replaceable filters.
- Supply air grilles have double-deflection, moveable louvers available in anodized bronze or aluminum finish.

Aluminum Grilles

- Supply air grilles have adjustable louvers to direct air flow.
- Return air grilles feature durable fixed-vane louvers.
- Return air grilles are supplied with or without filters depending on system requirements.
- Painted grilles are sprayed with polyurethane.
- Multiple color selection.

Grille Sizing Per Unit

Unit Capacity in BTU/hr	Return		Supply	
	Sq. In.	Sq. cm	Sq. In.	Sq. cm
4,000	64	412.9	32	206.5
5,000	64	412.9	32	206.5
6,000	70	451.6	35	225.8
7,000	80	516.2	45	290.3
9,000	98	632.3	49	316.1
10,000	100	645.2	60	387.1
12,000	130	838.8	70	451.6
16,000	160	1032.3	80	516.2
18,000	200	1290.4	100	645.2
24,000	240	1548.5	140	903.3
30,000	350	2258.2	170	1096.8
36,000	360	2322.7	196	1264.6
48,000	480	3097.0	256	1651.7

Notes:

- Supply and Return Air Grille minimums are required to achieve rated capacity.
- Custom sizes and custom painted grilles are available. Contact Marine Air Systems for pricing and availability.

Product Characteristics

Wood Frame Grilles

- Cut-out dimensions are the nominal grille size, i.e., a 10" X 5" VH requires a 10" X 5" (25.4cm X 12.7cm) cut out.
- Outside frame dimensions are 0.9375" ± 0.0625" (2.4cm ± 0.16cm) larger than nominal grille size, i.e., a 10" X 5" VH has overall dimensions or 10.9375" X 5.9375" (27.8cm X 15.1cm).
- Depth of grilles: VH is 1.375" (3.5cm), VML is 1.875" (4.8cm), RA is 0.875" (2.2cm), measured from back of frame.
- Frame (flange) dimensions are 0.563" (1.4cm) on all sides.

Aluminum Grilles

- Cut-out dimensions for the TH, TV, and TRA style grilles are 0.375" (1.0cm) smaller than the nominal grille size, i.e., a 10" X 5" TH requires a 9.625" X 4.625" (24.4cm X 11.7cm) cut-out. The TRAF style grilles are 0.125" (0.3cm) smaller.
- Outside frame dimensions are 0.875" (2.2cm) larger than the nominal grille size, i.e., a 10" X 5" TH has overall dimensions of 10.875" X 5.875" (27.6cm x 14.9cm).
- Depth of grilles: TH and TRA are 0.875" (2.2cm), TRAF is 1" (2.5cm), measured from back of frame.
- Frame (flange) dimension is 0.625" (1.6cm) on all sides.

Plastic Grilles (Circular)

- Depth of grilles: 2SA is 1.31" (3.3cm), 3SA is 2.16" (5.5cm), 4SA is 2.38" (6.0cm), measured from back of frame.
- Frame (flange) dimensions: 2SA is 2.75" (7.0cm), 3SA is 3.875" (9.8cm), 4SA is 5.50" (14.0cm), in diameter.
- Cut-out dimensions are 2.0" (5.1cm), 3.0" (7.6cm), and 4.0" (10.2cm) respectively, in diameter.
- A special adapter is available to use the 4SA with 3.0" (7.6cm) ducting.

DOMETIC MARINE DIVISION

2000 N. Andrews Ave. Ext. I Pompano Beach, FL 33069 USA | 954-973-2477 | Fax 954-979-4414
www.DomesticUSA.com | MarineSales@DomesticUSA.com

24/7 Tech Support for United States & Canada:

8:00 AM to 5:00 PM Eastern Time: 800-542-2477
After hours and weekends: 888-440-4494

International Sales & Service:

Europe & the Middle East: Call +44(0)870-330-6101
For all other areas visit our website to find your nearest distributor.



Environmentally
Responsible

Grille Dimensions

Wood Frame Grilles			
Supply Air, Primary		Supply Air, Secondary Closeable	
Model VH		Model VML	
7" X 7"	10" X 5"	4" X 4"	6" X 4"
12" X 5"	14" X 4"	8" X 4"	8" X 8"
14" X 5"	14" X 6"	10" X 4"	12" X 4"
16" X 4"			
Supply Air, Secondary		Return Air with Filter	
Model VH		Model RA	
4" X 4"	6" X 4"	7" X 7"	12" X 14"
8" X 4"	10" X 4"	8" X 8"	14" X 7"
10" X 4"	12" X 4"	8" X 10"	14" X 10"
		11" X 8"	14" X 12"
		12" X 12"	16" X 9"
Plastic Grilles (Round and Closeable Supply Air Grilles)			
Model	2SA	3SA	4SA
Duct Size	2"	3"	4"
Aluminum Grilles			
Supply Air		Return Air	
Model TH	Model TV	Model TRAF (with Filter); Model TRA (without Filter)	
4" X 4"	10" X 4"	8" X 11"	14" X 7"
7" X 7"	12" X 3"	10" X 4"	14" X 10"
8" X 4"	12" X 4"	11" X 7"	14" X 12"
10" X 4"	12" X 5"	11" X 8"	16" X 9"
10" X 5"	12" X 6"	11" X 12"	20" X 5"
	14" X 4"	12" X 12"	22" X 7"
	14" X 5"		28" X 6"
	14" X 6"		
	14" X 7"		
	16" X 4"		
	18" X 3"		
	20" X 5"		
	24" X 3"		

Note:

- Multiply the dimensions above by 2.54 to calculate for centimeters.

Dealer:

Ducting & Transition Boxes

A Full Range of Diameters & Lengths Available



Vacuum formed and aluminum transition boxes, and ducting shown

Specifications

Vacuum-Formed Transitions:

- Opening dimensions are 0.375" (0.95cm) larger than transition size (i.e., 10" X 5" VF has a 10.375" X 5.375" opening. 25.4cm X 12.7cm VF has a 26.4cm X 13.7cm opening).
- Flange to flange dimensions are 1.5" (3.8cm) larger than transition size (i.e., 10" X 5" VF = 11.5" X 6.5" flange to flange. 25.4cm X 12.7cm VF = 29.2cm X 16.5cm flange to flange).
- Depth of 4x VF models is 4.0" (10.2cm) (measured from back of flange).
- Depth of 5x and 6x VF models i.e., either 4.5" (11.4cm) or 5.75" (14.6cm) depending on use of round or obround rings.
- Flange dimensions are 0.5625" (1.43cm) on all sides.

Square Vacuum-Formed Transitions:

- Available in 5.25" and 6.25" (13.34cm and 15.88cm) square vacuum-formed transition boxes.
- Opening dimensions are 0.5" (1.27cm) larger than transition size.
- Flange to flange dimensions are 1.75" (4.4cm) larger than transition size.
- Depth is 0.125" (0.32cm) longer than the transition size.
- Flange dimensions are 0.625" (1.59cm) on all sides.

Vacuum Formed T-Boxes:

- Height of 10,000, 12,000 and 16,000 T-box with mounting flange is 7.875" (20.0cm).
- Height of 7,000 T-box with mounting flange is 6.875" (17.5cm).
- The 10,000, 12,000 and 16,000 T-boxes accommodate 6", 5" and 4" duct rings on one side and 5", 4" and 3" duct rings on the other side (15.2cm, 12.7cm, 10.2cm and 12.7cm, 10.2cm, 7.6cm respectively).

(Continued on reverse side)

Key Benefits

Ducting Design

- Two types of ducting available: round/wire with woven fabric and round/wire and mylar fabric shell with 1.0" (2.6cm) wall thickness insulation.
- Full range of diameters and lengths.
- All ducting attaches easily to associated rings.

Transition Box Design

- Large selection and variety available in aluminum and ABS plastic.
- Air flow designed and tested components.
- Matched to Marine Air Systems' grilles and blowers.
- Non-restrictive air flow.
- All rings designed for close tolerance fit with ducting.
- Perimeter flanges on all boxes for mounting ease.
- Aluminum Style Transitions and Boxes are fully insulated, available in standard and custom sizes, and are ideal for applications where space is limited.

(Continued on reverse side)

- The 7,000 T-box accommodates 5" and 4" duct rings on one side and 4" and 3" duct rings on the other side (12.7cm, 10.2cm and 10.2cm, 7.6cm respectively).

Aluminum Transitions:

- Opening dimensions are 0.25" (0.64cm) larger than transition size (i.e., 10" X 5" AL has a 10.25" X 5.25" opening. 25.4cm x 12.7cm AL has a 26.0cm X 13.3cm opening).
- Flange to flange dimensions are 1.75" (4.4cm) larger than transition size (i.e., 10" X 5" AL = 11.75" X 6.75". 25.4cm X 12.7cm AL = 29.8cm X 17.1cm).
- Depth of AL transition box is 0.25" (0.64cm) longer than the diameter of largest round ring (measured from back of flange).
- Flange dimensions are 0.75" (1.9cm) on all sides.

Obround Rings Dimensions:

- 3"OB = 3.875" X 1.625" (9.84cm X 4.13cm)
- 4"OB = 5.125" X 2.250" (13.02cm X 5.72cm)
- 5"OB = 6.500" X 2.625" (16.51cm X 6.67cm)
- 6"OB = 7.438" X 3.375" (18.89cm X 8.57cm)
- 7"OB = 9.000" X 3.625" (22.86cm X 9.21cm)
- 8"OB = 9.250" X 5.000" (23.50cm X 12.70cm)
- All obround rings are made of ABS plastic, except the 8"OB which is made of aluminum. Add 0.25" (0.64cm) to obround dimensions for minimum box size. All rings are 2.0" (5.1cm) deep.

VF = Vacuum Formed AL = Aluminum

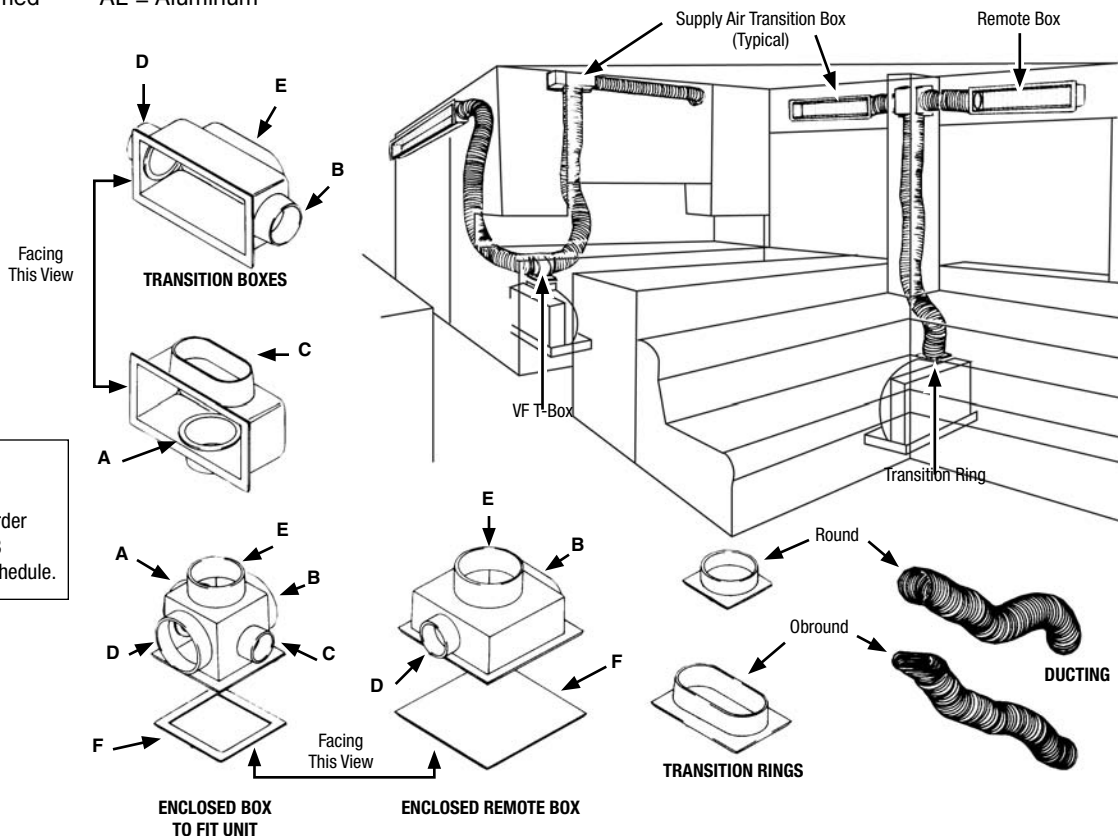

NOTE: Letters denote location of rings when ordering boxes. See order form found in ID: 2163 Marine Air DX price schedule.

Key Benefits (continued)

- Versatile ABS plastic transitions and boxes feature off-the-shelf availability and are vacuum formed for consistent quality.
- ABS plastic T-boxes have insulated mounting pads, unique stepped ring design for flexibility, and feature off-the-shelf availability.

DOMETIC MARINE DIVISION
 2000 N. Andrews Ave. Ext. I Pompano Beach, FL 33069 USA | 954-973-2477 | Fax 954-979-4414
 www.DomesticUSA.com | MarineSales@DomesticUSA.com

24/7 Tech Support for United States & Canada:
 8:00 AM to 5:00 PM Eastern Time: 800-542-2477
 After hours and weekends: 888-440-4494

International Sales & Service:
 Europe & the Middle East: Call +44(0)870-330-6101
 For all other areas visit our website to find your nearest distributor.



Dealer:

Dometic EnviroComfort Kit

Climate Control at the Touch of a Button

50Hz Models
Now Available!



Dometic EnviroComfort
15,000 BTU/hr Kit

Enjoy ideal temperatures in your boating environment year-round with Dometic's EnviroComfort air conditioning systems. We offer a wide range of capacities from 5,000 to 15,000 BTU/hr, so you can size the system to suit your boat for ultimate cooling and heating comfort. All EnviroComfort models use R-417A refrigerant, an environmentally safe gas.

The EnviroComfort kit includes everything needed for a professional installation on boats with or without an existing air conditioning system.

EnviroComfort units use high-velocity blowers that eliminate blower-motor overhang for a smaller installation footprint. For flexibility in connecting to ductwork, the blower is rotatable to either a horizontal or vertical position. The compact, space-saving design is contained in a stainless-steel drain pan, and the pre-installed return-air filter is easily removable and cleanable.

For system operation, EnviroComfort kits include a compact Dometic digital-display control. For added installation convenience, the plastic electrical box can be mounted remotely.



For applications requiring an additional air outlet, Dometic's dual-duct kit (shown at left) is available for EnviroComfort models with BTU/hr capacities of 6.5K and higher.

Key Benefits

- Cools and heats.
- Available in 50Hz and 60Hz models.
- High velocity, rotatable blower for horizontal or vertical installation.
- Green gas (R-417A).
- Compact Dometic digital-display control.
- Plastic remote electrical box for convenience in mounting.
- Stainless-steel drain pan.
- Pre-installed return-air filter, easily removable and cleanable.
- Small, compact, space-saving design.
- Complete kit - All pieces, parts, and pumps (from seawater intake to supply-air grille).
- Optional dual-duct kit for models 6.5K BTU/hr and higher (details on reverse side).
- Available capacities (in BTU/hr): 5,000, 6,500, 9,000, 11,000, and 15,000.
- Replaces Cabin Mate.

Technical Specifications for Dometic EnviroComfort Air Conditioners

Model	ECD05		ECD06.5	ECD09	ECD11		ECD15	
Capacity (BTU/hr)	5,000		6,500	9,000	11,000		15,000	
Power (Volt/Hz/Ph)	115/60/1	220/50/1	115/60/1	115/60/1	115/60/1	220/50/1	115/60/1	220/50/1
Full Load Amps - Cool	3.8	2.2	5.4	6.3	6.8	3.7	10.0	4.5
Full Load Amps - Heat	5.0	2.9	7.0	8.6	9.4	4.7	13.0	5.8
Locked Rotor Amperage	29.0	11.0	40.0	49.0	53.0	22.2	67.0	32.0
Refrigerant type	R-417A		R-417A	R-417A	R-417A		R-417A	
Control type	Dometic Digital		Dometic Digital	Dometic Digital	Dometic Digital		Dometic Digital	
Dimensions (± 0.5" or 13mm)								
Height (in/mm)	11.75/298		11.75/298	13.50/343	13.50/343		13.50/343	
Width (in/mm)	9.50/241		9.50/241	9.75/248	9.75/248		11.00/279	
Depth (in/mm)	17.75/451		19.75/502	21.75/552	21.75/552		21.75/552	
Connections								
Sea Water (in/mm)	0.63/16		0.63/16	0.63/16	0.63/16		0.63/16	
Estimated Weight⁽¹⁾								
Net weight (lbs/kg)	39.0/17.7		44.0/19.6	58.0/26.3	57.0/25.9		64.0/29.0	
Ship weight (lbs/kg)	TBD		TBD	TBD	TBD		TBD	

Notes:

⁽¹⁾ Weights listed are for ECM units only and do not include kit components.

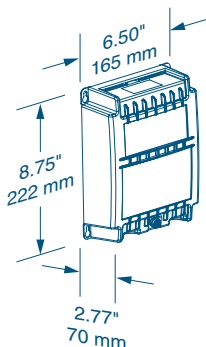
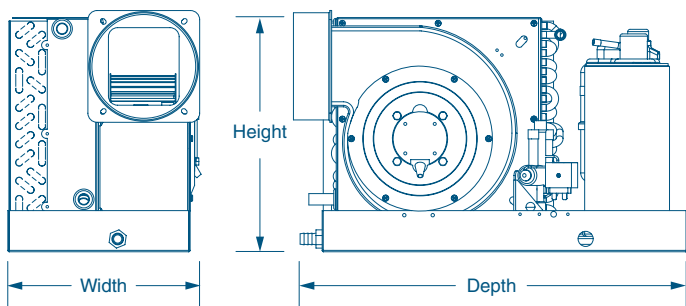

Dimensions for remote-mountable electrical box for all ECD models.

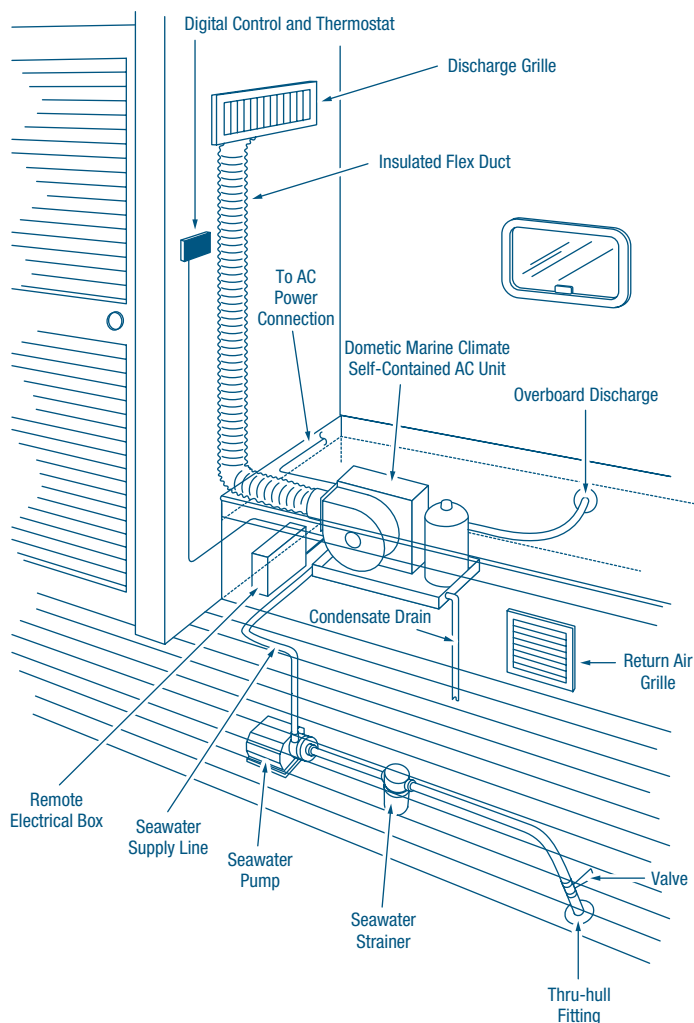

DOMETIC MARINE DIVISION

2000 N. Andrews Ave. Ext. I Pompano Beach, FL 33069 USA | 954-973-2477 | Fax 954-979-4414
 www.DometicUSA.com | MarineSales@DometicUSA.com

24/7 Tech Support for United States & Canada:

8:00 AM to 5:00 PM Eastern Time: 800-542-2477
 After hours and weekends: 888-440-4494

International Sales & Service:

Europe & the Middle East: Call +44(0)870-330-6101
 For all other areas visit our website to find your nearest distributor.



Environmentally Responsible

Dealer:

Dometic EnviroCool Kit

Climate Control at the Touch of a Button

50Hz Models
Now Available!



Dometic EnviroCool
5,000 BTU/hr Kit

Enjoy ideal temperatures in your boating environment with Dometic's EnviroCool Series of marine air conditioning kits. The EnviroCool Series offers a wide range of BTU capacities from 3,500 to 15,000 BTU/hr to allow you to size your system for ultimate cooling. The EnviroCool series uses environmentally safe R-134A (3.5K BTU/hr. model) and R-417A (5K - 15K BTU/hr. models) refrigerants.

The EnviroCool kit includes everything needed for a professional installation on boats with or without an air conditioning system.

EnviroCool units use high-velocity blowers that eliminate blower-motor overhang for a smaller installation footprint. For flexibility in connecting to ductwork, the blower is rotatable to either a horizontal or vertical position. The compact, space-saving design is contained in a stainless-steel drain pan, and the pre-installed return-air filter is easily removable and cleanable.

For system operation, EnviroCool uses a two-knob mechanical switch for reliable control over air conditioner functions.

Key Benefits

- Small, compact space-saving design.
- Stainless-steel drain pan.
- Available in 50Hz and 60Hz models.
- Green gas (R-134A and R-417A).
- Two-knob mechanical control.
- Complete air conditioning kit - All pieces, parts, and pump.
- High velocity, rotatable blower - either horizontal or vertical positions.
- Pre-installed return-air filter, easily removable and cleanable.
- Optional dual-duct kit for 6.5K BTU/hr and up models (details on reverse side).
- Available capacities (in BTU/hr): 3,500, 5,000, 6,500, 9,000, 11,000, and 15,000.
- Replaces Cool Mate and Zephyr.

Technical Specifications for Dometic EnviroCool Air Conditioners

Model	ECM03.5	ECM05		ECM06.5	ECM09	ECM11		ECM15	
Capacity (BTU/hr)	3,500	5,000		6,500	9,000	11,000		15,000	
Power (Volt/Hz/Ph)	115/60/1	115/60/1	220/50/1	115/60/1	115/60/1	115/60/1	220/50/1	115/60/1	220/50/1
Full Load Amps - Cool	4.3	3.8	2.2	5.4	6.3	6.8	3.7	9.4	4.5
Locked Rotor Amperage	14.0	29.0	11.0	40.0	49.0	53.0	22.2	59.0	32.0
Refrigerant type	R-134A	R-417A		R-417A	R-417A	R-417A		R-417A	
Control type	Mechanical	Mechanical		Mechanical	Mechanical	Mechanical		Mechanical	
Dimensions (± 0.5" or 13mm)									
Height (in/mm)	9.50/241	11.75/298		11.75/298	13.50/343	13.50/343		13.50/343	
Width (in/mm)	9.75/248	9.50/241		9.50/241	9.75/248	9.75/248		11.00/279	
Depth (in/mm)	17.75/451	17.75/451		19.75/502	21.75/552	21.75/552		21.75/552	
Connections									
Sea Water (in/mm)	0.63/16	0.63/16		0.63/16	0.63/16	0.63/16		0.63/16	
Estimated Weight⁽¹⁾									
Net weight (lbs/kg)	25.0/11.3	39.0/17.7		45.0/20.4	54.0/24.5	54.0/24.5		60.0/27.2	
Ship weight (lbs/kg)	32.0/14.5	50.0/22.7		TBD	TBD	TBD		72.0/32.7	

Notes:

⁽¹⁾ Weights listed are for ECM units only and do not include kit components.

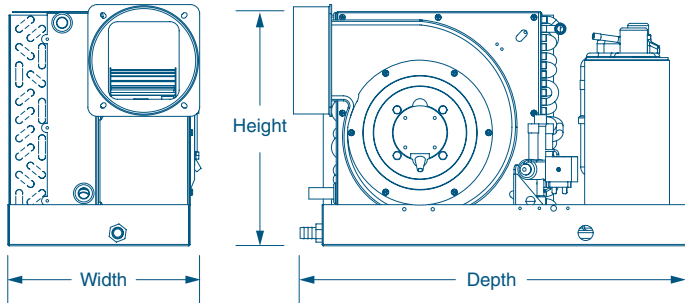

Dual-Duct Kit

For applications requiring an additional air outlet, Dometic's dual-duct kit is available for 6.5-15K BTU/hr EnviroCool models.

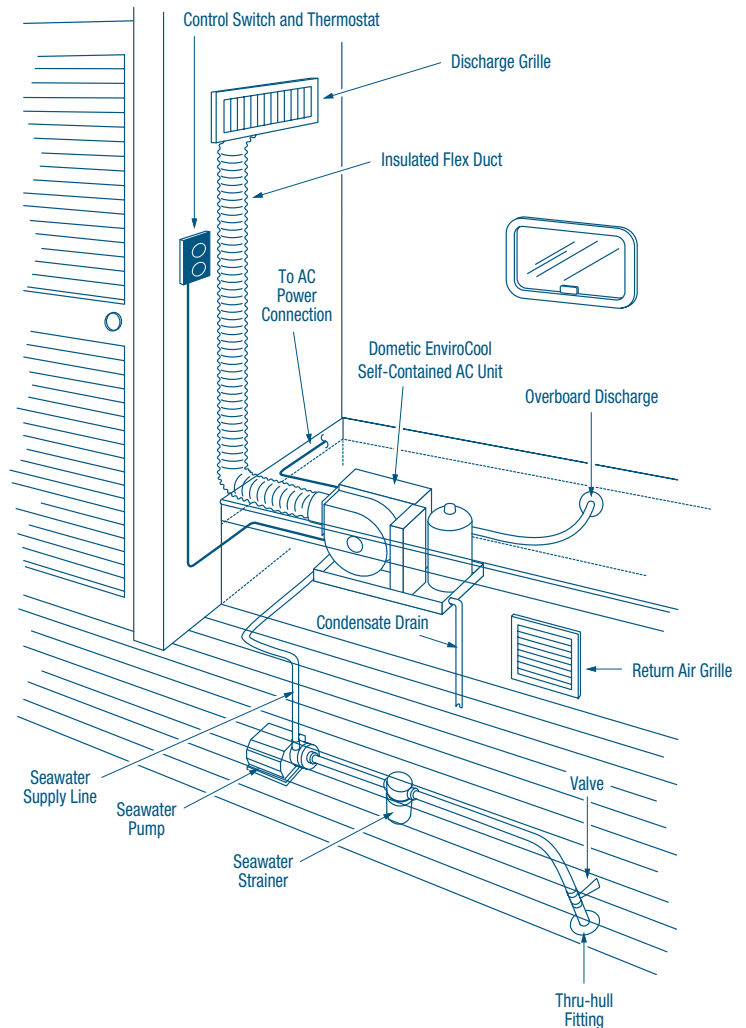

DOMETIC MARINE DIVISION

2000 N. Andrews Ave. Ext. I Pompano Beach, FL 33069 USA | 954-973-2477 | Fax 954-979-4414
www.DometicUSA.com | MarineSales@DometicUSA.com

24/7 Tech Support for United States & Canada:

8:00 AM to 5:00 PM Eastern Time: 800-542-2477
After hours and weekends: 888-440-4494

International Sales & Service:

Europe & the Middle East: Call +44(0)870-330-6101
For all other areas visit our website to find your nearest distributor.



Environmentally Responsible

Dealer:

DuraSea Condensing Units

Designed for Maximum Durability



DCA60D shown; optional risers not shown



Dometic DuraSea air conditioning condensing units are designed for maximum durability in the harshest of nautical applications. These rugged units offer long service life, exceptional performance, energy conservation, and reliability.

The DuraSea's cabinet is constructed of stainless-steel 304, which resists heavy salt-spray and also provides UV protection. Designed for deck or rooftop mount, the optional risers elevate the unit above the mounting surface to provide excellent water drainage and protect the coil from debris and salt water. To further fortify the unit from severe marine conditions, corrosion-resistant stainless-steel fasteners are used, and all other external components have a protective coating. The control box and compressor are strategically located within the cabinet for easy service access and for extra protection against corrosion.

All DuraSea units employ scroll compressors, the latest in high-efficiency, reliable compressor technology. They reduce noise and vibration, and have a higher tolerance of liquid refrigerant and system contaminants. Scroll compressors also feature low start torque to minimize the starting-current spike that occurs with old-technology compressors.



DCA60D shown with service panel removed

Key Benefits

- Designed specifically for the rugged workboat market.
- Operates with most air handler units.
- Hermetically sealed scroll compressor with internal overload protection.
- Permanently lubricated condenser fan motor with VIP Vacuum Impregnated windings.
- High-efficiency copper tube/aluminum fin coil with dipped coating that exceeds 1000-hour salt spray test.
- Copper tube/copper finned coils are available for ultimate protection.
- Brass base valves with sweat connections and service ports.
- Vertical fan-mount design.
- High- and low-pressure controls.
- Heavy-duty contactor with lug connections.

Technical Specifications for DuraSea Condensing Unit (Standard Models)

Model	DCA36D	DCA36E	DCA48D	DCA48E	DCA60D	DCA60E	DCA72D	DCA72E	DCA90D	DCA90E	DCA120D	DCA120E
Capacity (BTU/hr)	36,000	36,000	48,000	48,000	60,000	60,000	72,000	72,000	90,000	90,000	120,000	120,000
RLA	9.7	4.9	12.7	6.5	16.7	8.3	20.7	10.0	32.1	16.4	42.0	19.2
LRA	77	39	91	50	128	63	156	70	195.0	95.0	239.0	125.0
MCC	16	8	23	11	29	14	29	14	45.0	23.0	58.9	26.9
CFM	6000	6000	6000	6000	6000	6000	6000	6000	6000	6000	10000	10000
Motor FLA	3.6	2.0	3.6	2.0	3.6	2.0	3.6	2.0	3.6	2.0	8.5	4.9
Liquid Valve Size (OD) ⁽¹⁾	3/8"	3/8"	3/8"	3/8"	1/2"	1/2"	1/2"	1/2"	1/2"	1/2"	5/8"	5/8"
Suction Valve Size (OD) ⁽¹⁾	3/4"	3/4"	7/8"	7/8"	7/8"	7/8"	7/8"	7/8"	1-1/8"	1-1/8"	1-3/8"	1/3/8"
Refrigerant Charge	80	80	80	80	120	120	120	120	150	150	150	150
Volts/Hz/Phase	208-230/ 60/3	460/ 60/3	208-230/ 60/3	460/ 60/3	208-230/ 60/3	460/ 60/3	208-230/ 60/3	460/ 60/3	208-230/ 60/3	460/ 60/3	208-230/ 60/3	460/ 60/3
Min. Circuit Amps ⁽²⁾	16	8	20	10	25	15	30	15	45	25	65	30
Max. Breaker Protection ⁽³⁾	20	15	30	15	40	20	40	20	60	30	80	35
Min./Max. Volts	197/253	414/506	197/253	414/506	197/253	414/506	197/253	414/506	197/253	414/506	197/253	414/506
Sound Level (dbA) ⁽⁴⁾	84	84	84	84	84	84	84	84	84	84	87	87
Unit Weight (lbs/kg) ⁽⁵⁾	290/132	290/132	310/141	310/141	365/166	365/166	375/170	375/170	475/215	475/215	525/238	525/238

Notes:

- ⁽¹⁾ Up to 50' (15.2 m) in equivalent line length.
- ⁽²⁾ Wire size should be determined in accordance with National Electric Codes. Extensive wire runs require larger wire sizes.
- ⁽³⁾ Must use time-delay fuses or HACR type circuit breakers of the same size as noted.
- ⁽⁴⁾ Sound level measured at 3' (0.9 m) away from condensing unit.
- ⁽⁵⁾ Weight for aluminum fin condenser coil with coating.

*In the interest of product improvement, all data is subject to change at Dometic's discretion.

DCA Dimensions (Standard Models)

Model	Dimensions (in/mm)		
	Width	Depth	Height
DCA36	33.0/838	33.0/838	38.5/978
DCA48	33.0/838	33.0/838	38.5/978
DCA60	33.0/838	33.0/838	38.5/978
DCA72	33.0/838	33.0/838	38.5/978
DCA90	33.0/838	48.0/1219	42.0/1067
DCA120	33.0/838	48.0/1219	42.0/1067

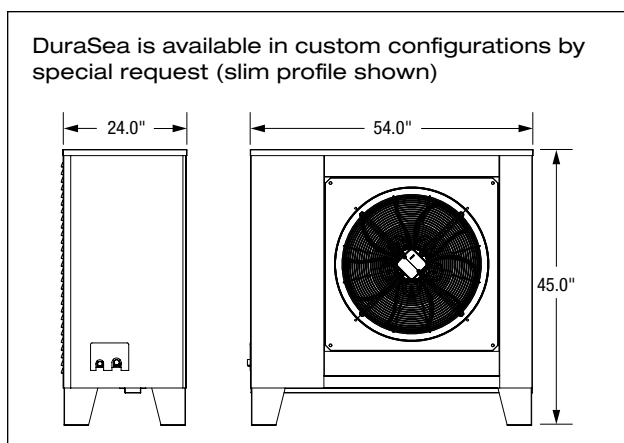

Commitment to Quality

Built with quality inside and out by Dometic, the world leader in marine air conditioning for 50 years. Every DuraSea condensing unit is factory charged and thoroughly run tested. DuraSea units meet or exceed ABYC and USCG regulations, CE directives, and general ARI standards.



DOMETIC MARINE DIVISION

2000 N. Andrews Ave. Ext. I Pompano Beach, FL 33069 USA | 954-973-2477 | Fax 954-979-4414
 www.DometicUSA.com | MarineSales@DometicUSA.com

24/7 Tech Support for United States & Canada:

8:00 AM to 5:00 PM Eastern Time: 800-542-2477
 After hours and weekends: 888-440-4494

International Sales & Service:

Europe & the Middle East: Call +44(0)870-330-6101
 For all other areas visit our website to find your nearest distributor.



Environmentally Responsible

Dealer:

Radome Environmental Control Units

Keep Your Equipment Cool

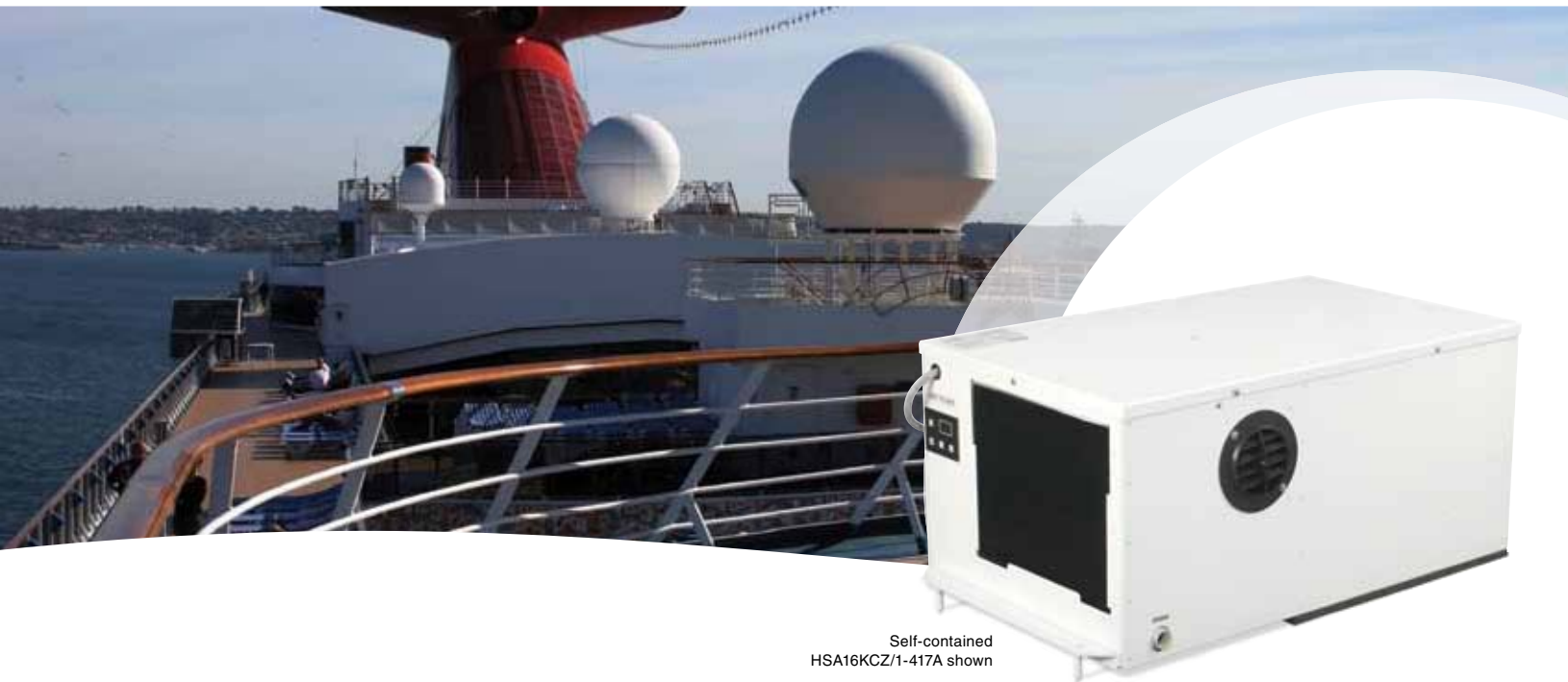

Self-contained
HSA16KCZ/1-417A shown

Safe navigation relies on your ship's radar and communications equipment, and as with all electronics, overheating leads to equipment failure. The Radome Environmental Control Unit (ECU) is specifically designed to work within the dome enclosure, ensuring optimum temperatures for the critical equipment inside.

As you would expect from the world leader in marine air conditioning technology, this air-cooled unit is built for at-sea conditions. Although small and lightweight to provide ease of installation and maintenance, the Radome ECU is designed to exceed the cooling requirements of pleasure boat, commercial vessel, and military ship applications. Rugged construction with corrosion-resistant materials allows the unit to be operated in the most extreme conditions at sea.

The Radome ECU's highly efficient yet powerful rotary compressor provides quieter operation, increased reliability, and reduced amperage. Its raised-lance fin and the rifled tubing design of the evaporator and condenser coils provide maximum capacity. Three configurations are offered: interior dome self-contained, remoted ducted self-contained, and split-gas.

The Radome ECU is not limited to marine applications. It can also control the temperature and humidity levels of on-land locations such as electronics enclosures, telecommunications shelters, vaults, buildings, trailers, vans, and cleanrooms.

Key Benefits

- 3 configurations: Self-contained interior dome, self-contained remote ducted, and split-gas.
- Compact, lightweight, and easy to install.
- Durable, corrosion-resistant coating.
- Available in R-417A environmentally-safe refrigerant.
- R-22 units are retrofittable to R-417A to meet global environmental regulations.
- Solid state digital control provides reliable monitoring and control.
- Control circuitry monitors and protects the unit.
- High-efficiency rotary compressors provide reduced amperage, quieter operation, lower weight, and increased reliability.
- Raised lance fin and rifled tubing for maximum capacity.
- Each unit is pre-charged and leak checked.
- Charge Guard® protection provides sealed access ports, ensuring environmental protection and system integrity.
- Meet or exceed applicable ABYC and U.S. Coast Guard regulations, CE directives, and general Air Conditioning and Refrigeration Industry (ARI) standards.

Technical Specifications for Radome Environmental Control Units

Model	Radome ECU Unit		
Capacity (BTU/hr)	16,000		
Voltage/Hz/Ph	115/50-60/1	230/60/1 ⁽¹⁾	220/50/1
Locked Rotor Amps (Comp)	67.0	29.0	32.0
K.V.A. (Kilo-Volt-Amps)	1.3	1.3	1.3
Max. Circuit Breaker (Amps)	40.0	20.0	20.0
Min. Circuit Ampacity	25.0	14.0	12.0
R-417A Refrigerant (oz/g)	26/737		
Net Weight (lbs/kg)	95.0/43.1		
Gross Weight (lbs/kg)	130.0/59.0		



Radome ECU split-gas system shown above

Dimensions

Self-Contained (LxWxH) ⁽²⁾	Split (LxWxH) ⁽³⁾	
	Condenser	Air Handler
30.0" X 18.0" X 14.5" 762mm X 457mm X 368mm	17.5" X 18.0" X 14.5" 445mm X 457mm X 368mm	12.7" X 18.0" X 14.5" 323mm X 457mm X 368mm

Notes:

- ⁽¹⁾ Can also be operated at 200-220V/50Hz.
- ⁽²⁾ Allow 1.5" (38mm) for mounting brackets.
- ⁽³⁾ Rotary compressors only.

The Radome ECU is available in three configurations:

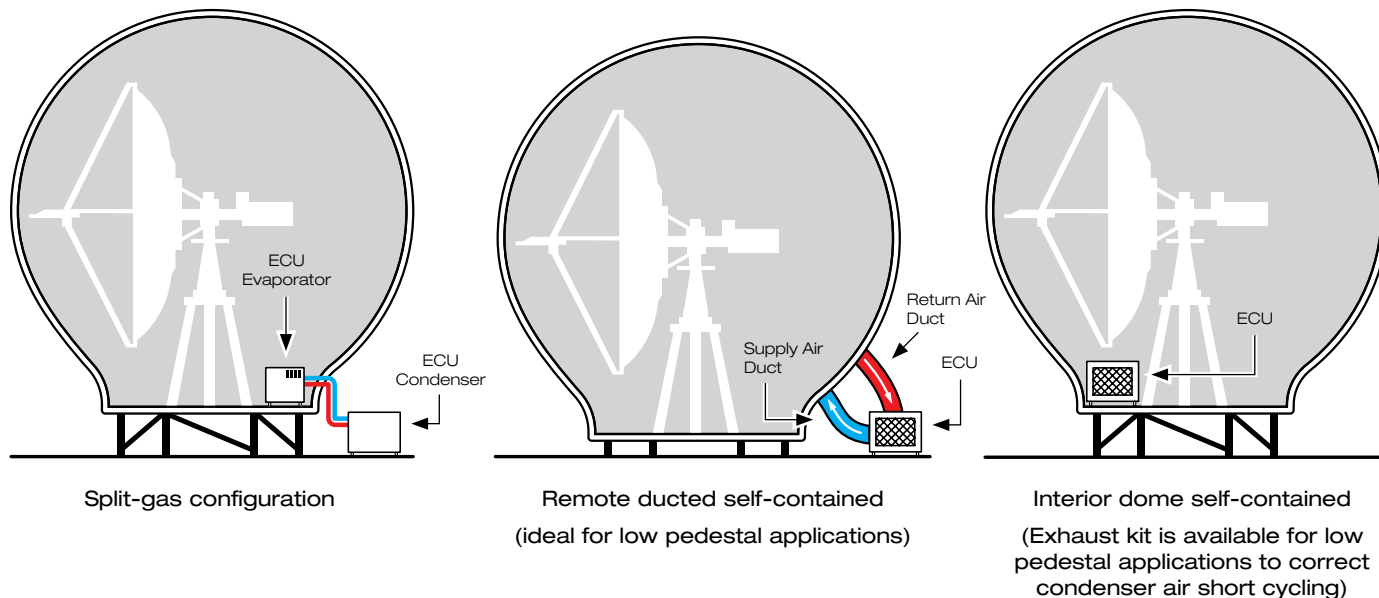

DOMETIC MARINE DIVISION

2000 N. Andrews Ave. Ext. I Pompano Beach, FL 33069 USA | 954-973-2477 | Fax 954-979-4414
www.DometicUSA.com | MarineSales@DometicUSA.com

24/7 Tech Support for United States & Canada:

8:00 AM to 5:00 PM Eastern Time: 800-542-2477
After hours and weekends: 888-440-4494

International Sales & Service:

Europe & the Middle East: Call +44(0)870-330-6101
For all other areas visit our website to find your nearest distributor.



Dealer:

Eskimo Ice Fishbox Ice Systems

For Serious Tournament Anglers



- Keep your catch fresh all day.

EI600D-115 Self-Contained Model



Crushed ice—preferred by fishermen—cools more quickly and packs better.

A Dometic Eskimo Ice system produces up to 600 pounds (272 kg) of crushed ice per day to keep even the largest catches fresh. Ice is generated within minutes after starting the unit, and makes up to 25 pounds (11.3 kg) of ice per hour under normal operating conditions.

The easy-to-install Eskimo Ice system is designed to be mounted below deck or in an engine room where it is protected from salt spray. The ice it produces can be pumped through hose lengths up to 30 feet (9.1 meters) to nearly any desired location onboard, such as a fish box or cooler.



All self-contained and remote Eskimo Ice systems feature the Smart Logic Digital Display. A full menu of sensors and status lights monitor gas pressure, auger motor, compressor, water level, ice level, and ice clogs, and will shut off the system if problems are detected. The system automatically resets and restarts for certain key functions that can be triggered by extreme boat motion.

Available in either 60Hz or 50Hz versions. Digital-control retrofit kits are available.

Key Benefits

- Available in 60Hz or 50Hz.
- Self-contained and remote models available with Smart Logic digital control.
- Up to two remotely mounted digital displays/user interface panels.
- Photo-electric ice-level sensor.
- Start-time delay.
- Fresh water filter included.
- Pre-charged system.
- Sensors monitor all system functions.
- Manual reset to restart system from lock-out.
- Improved fresh-water float switch.
- Redesigned refrigerant meter for improved performance in cold water.
- Optional side and top covers for protection and improved appearance.

Technical Specifications for Eskimo Ice 600 Series

Model	Volts/Freq/Ph	Running Amps	LRA	Capacity ⁽¹⁾	Water Consumption	Dimensions (in/mm)			Net Weight (lb/kg)
						Width	Depth	Height	
Remote Systems									
EIR600-115 Condensing Unit	115/60/1	14.0	66.3	N/A	N/A	12.88/327	12.88/327	15.00/381	67/30.5
EIR600-115 Auger Unit	115/60/1	2.0	N/A	600 lb/day	60 gal/day	14.25/362	16.38/416.1	20.88/530.4	83/37.7
EIR600-230 Condensing Unit	230/60/1	7.0	33.5	N/A	N/A	12.88/327	12.88/327	15.00/381	67/30.5
EIR600-230 Auger Unit	230/60/1	1.0	N/A	600 lb/day	60 gal/day	14.25/362	16.38/416.1	20.88/530.4	83/37.7
EIR600-220 Condensing Unit	220/50/1	6.5	40.0	N/A	N/A	12.88/327	12.88/327	15.00/381	67/30.5
EIR600-220 Auger Unit	220/50/1	1.0	N/A	500 lb/day ⁽²⁾	60 gal/day	14.25/362	16.38/416.1	20.88/530.4	83/37.7
Remote Electrical Box	N/A	N/A	N/A	N/A	N/A	9.25/234	5.38/136	6.38/162	4.00/1.81
Self-Contained Systems									
EI600D-115	115/60/1	16.0	66.3	600 lb/day	60 gal/day	17.50/445	23.50/597	22.00/559	135.00/61.4
EI600D-230	230/60/1	8.0	33.5	600 lb/day	60 gal/day	17.50/445	23.50/597	22.00/559	135.00/61.4
EI600D-220	220/50/1	7.5	40.0	500 lb/day ⁽²⁾	60 gal/day	17.50/445	23.50/597	22.00/559	135.00/61.4

Notes:
⁽¹⁾ Capacity ratings depend upon conditions.
⁽²⁾ Rated at 500 (227 kg) lbs per day because of 50Hz derate.

- The Eskimo Ice basic kit includes:**
- Ice Machine with condensate pan.
 - 15' (4.5m) of ice-delivery hose and insulation.
 - Electronic ice-level control unit.
 - Complete installation instructions.
 - Fresh water filter

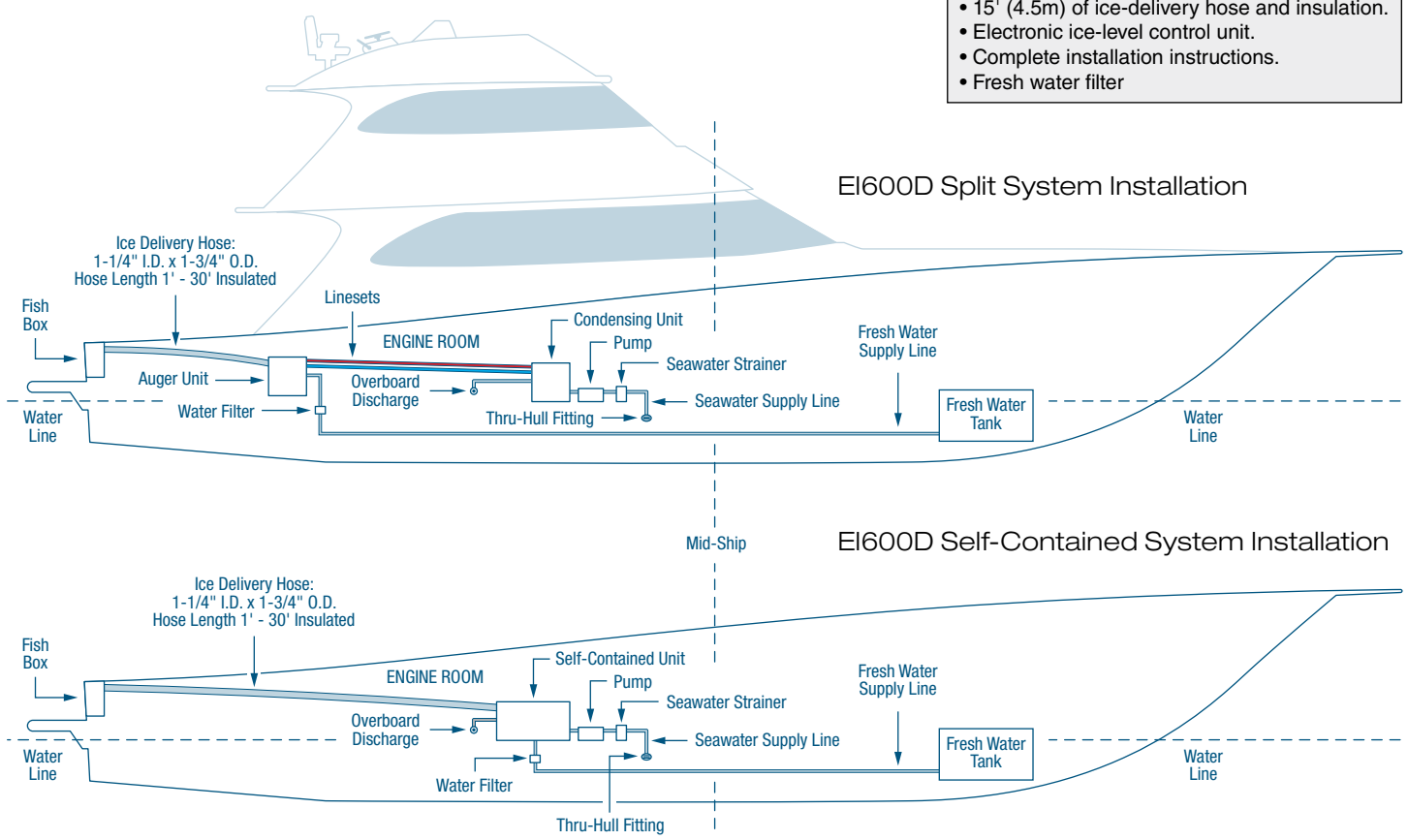

DOMETIC MARINE DIVISION
 2000 N. Andrews Ave. Ext. I Pompano Beach, FL 33069 USA | 954-973-2477 | Fax 954-979-4414
 www.DometicUSA.com | MarineSales@DometicUSA.com

24/7 Tech Support for United States & Canada:
 8:00 AM to 5:00 PM Eastern Time: 800-542-2477
 After hours and weekends: 888-440-4494

International Sales & Service:
 Europe & the Middle East: Call +44(0)870-330-6101
 For all other areas visit our website to find your nearest distributor.



Dealer:

Ice Cube Fishbox Ice System

Produces Up to 250 Lbs. of Ice a Day

50Hz Models
Now Available!



■ Keep your catch fresh all day.

EI250D-115 shown



The Ice Cube - A Smaller Crushed-Ice System

Dometic Eskimo Ice is available in a smaller version—the Ice Cube—for boats with less space or less demand for daily ice output. Cube-shaped, with a footprint of only 16" x 16" (413mm x 413mm), the Ice Cube makes up to 250 lbs. (113 kg) of crushed ice per day. Ice is generated within minutes after starting the unit, and makes more than 10 lbs. (4.5 kg) of ice per hour under optimal operating conditions.

The Ice Cube is a self-contained unit and easy to install. The ice it produces can be pumped through insulated hose lengths up to 15' (4.5m), to nearly any desired location onboard, such as a fish box or cooler.

Operation of the Ice Cube is easy with its Smart Logic Digital Displays. A full menu of sensors and status lights monitor gas pressure, auger motor, compressor, water level, ice level, and ice clogs, and will shut off the system if problems are detected. But the system automatically resets and restarts for certain key faults.



Key Benefits

- Small footprint—16" x 16" (413mm x 413mm).
- Available in 50Hz and 60Hz models.
- Up to two remotely mounted digital displays/user interface panels.
- Photo-electric ice-level sensor.
- Start-time delay.
- Water filter included.
- Pre-charged system.
- Sensors monitor all system functions.
- Manual reset to restart system after lock-out.
- Improved fresh-water float switch.
- Ventilated cover panels are removable for servicing from virtually any side of the unit.

Technical Specifications for Ice Cube

Model	EI250D-115	EI250D-220V/50
Capacity per day (lbs/kg)	250/113 ⁽¹⁾	
Capacity per hour (lbs/kg)	>10.42/>4.73 ⁽¹⁾	
Voltage	115	220
Frequency	60Hz	50Hz
Full Load Amps (FLA) Cool	9.68	4.50
Locked Rotor Amps (LRA)	40.00	14.80
Refrigerant	R-134A	
Water consumption, gallons per day	30 @ 250 lbs	
Water consumption, liters per day	113.56 @ 113.4	
Dimensions		
Height (in/mm)	16.25/413	
Width (in/mm)	16.25/413	
Length (in/mm)	16.25/413	
Connections		
Sea water (in/type)	5/8"/hose barb	
Fresh water (in/type)	1/4"/SAE	
Weight		
Net weight (lbs/kg)	82.0/37.2	
Shipping weight (lbs/kg)	97.0/43.9	

Notes:

⁽¹⁾ Under optimal conditions.

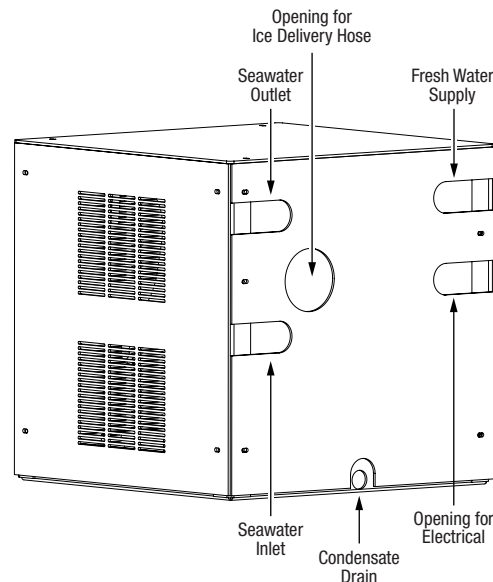

The Ice Cube basic kit includes:

- Ice Cube ice-making system.
- (1) Smart Logic digital display.
- Water filter.
- 15' (4.5m) of ice-delivery hose and insulation.

Recommended Ice Cube System Installation

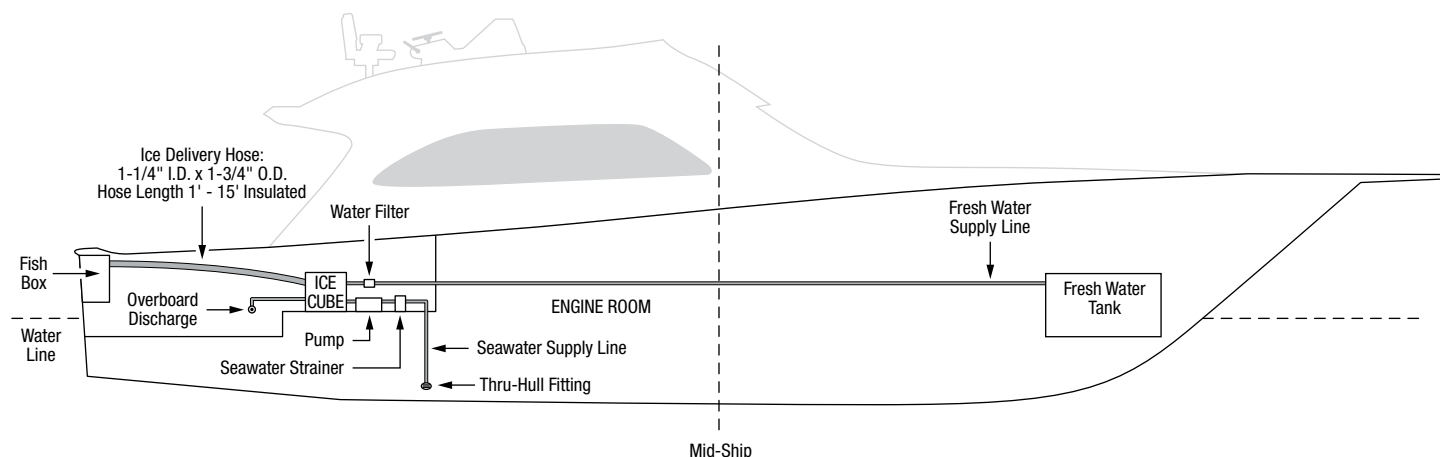

DOMETIC MARINE DIVISION

2000 N. Andrews Ave. Ext. I Pompano Beach, FL 33069 USA | 954-973-2477 | Fax 954-979-4414
 www.DometicUSA.com | MarineSales@DometicUSA.com

24/7 Tech Support for United States & Canada:

8:00 AM to 5:00 PM Eastern Time: 800-542-2477
 After hours and weekends: 888-440-4494

International Sales & Service:

Europe & the Middle East: Call +44(0)870-330-6101
 For all other areas visit our website to find your nearest distributor.



Environmentally Responsible

Dealer:

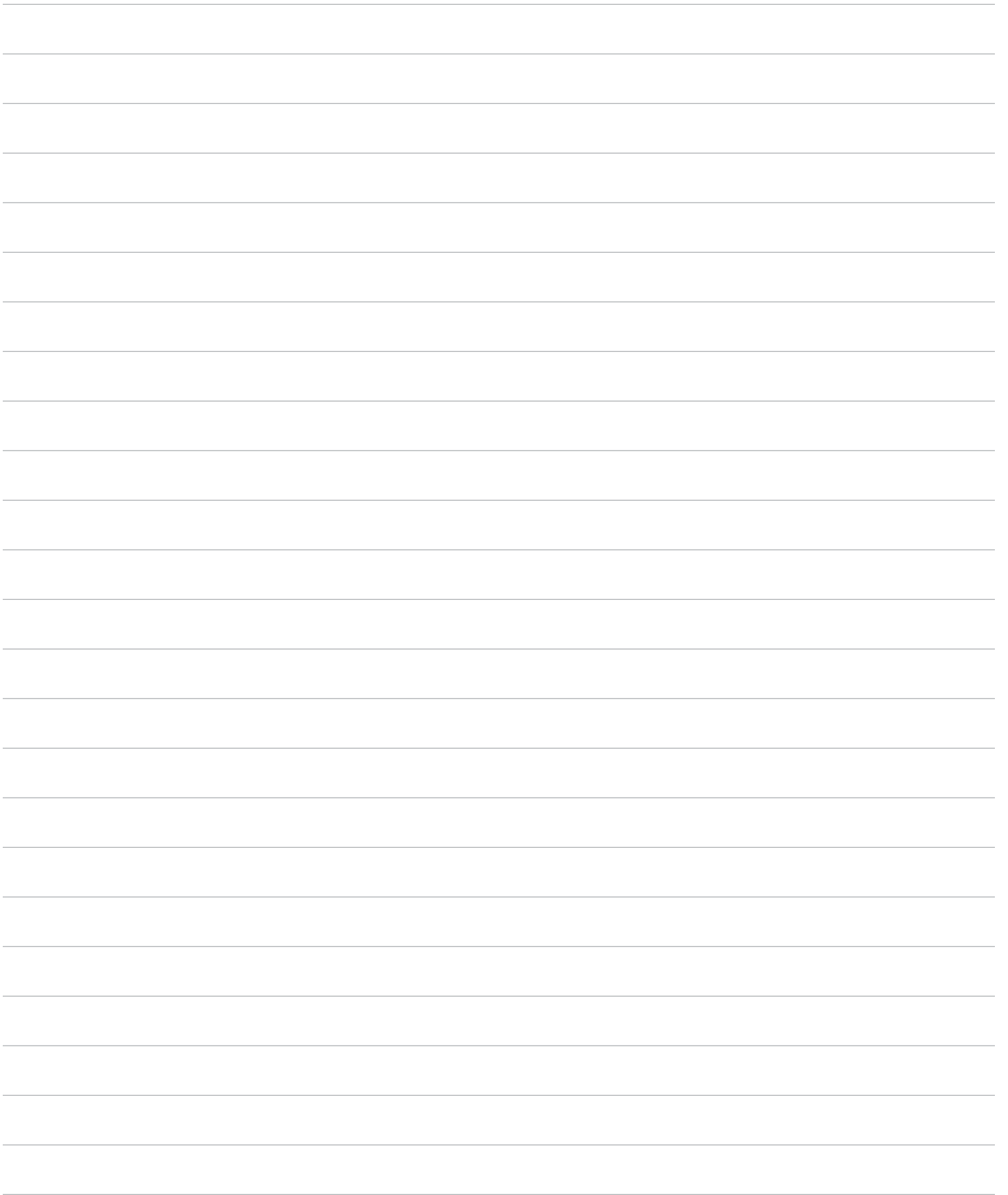

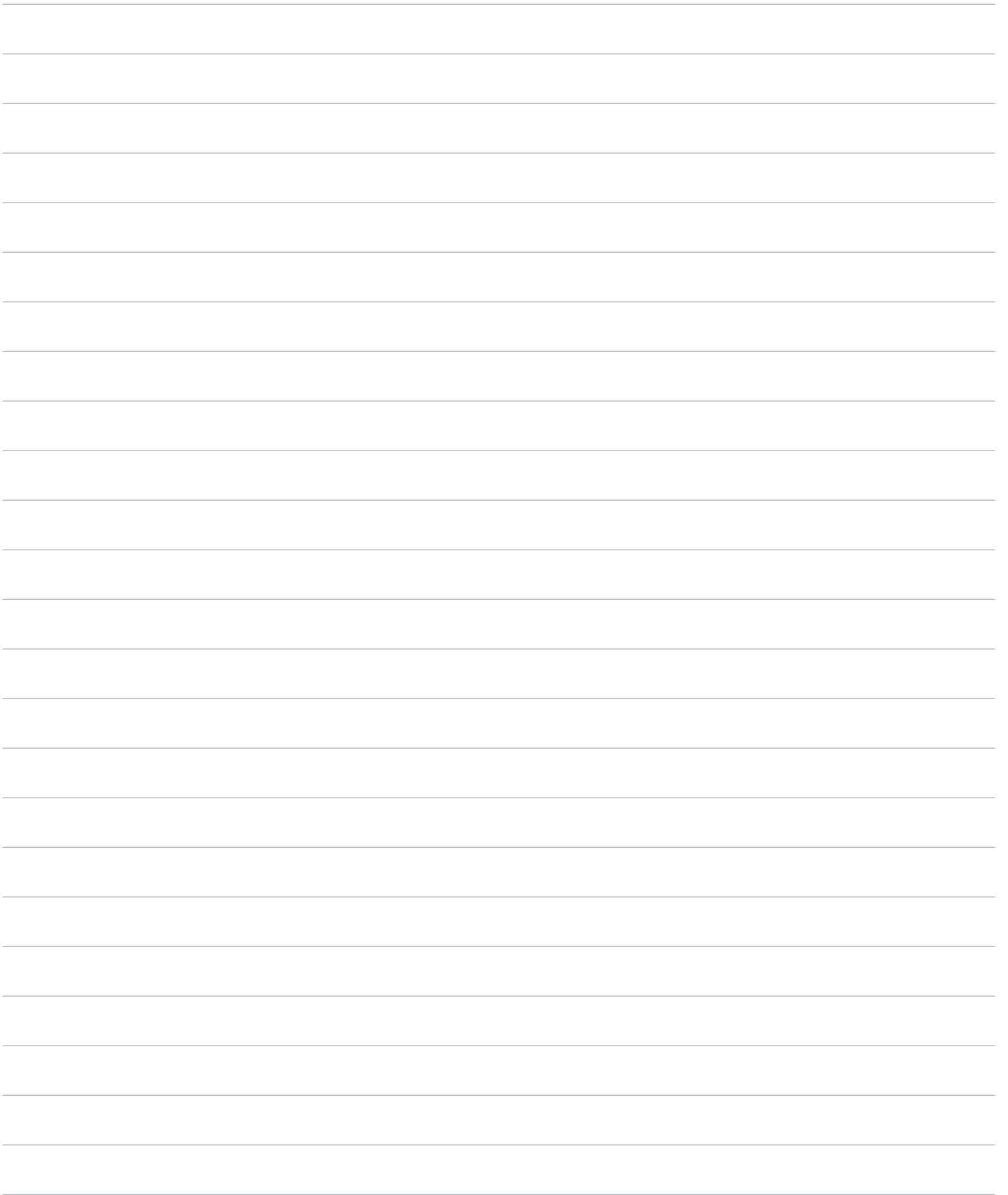

Certified Worldwide Sales & Service Network



Represents sales and service coverage range



DOMETIC MARINE DIVISION

2000 N. Andrews Ave. Ext. I Pompano Beach, FL 33069 USA | 954-973-2477 | Fax 954-979-4414
www.DometicUSA.com | MarineSales@DometicUSA.com

24/7 Tech Support for United States & Canada:

8:00 AM to 5:00 PM Eastern Time: 800-542-2477

After hours and weekends: 888-440-4494

International Sales & Service:

Europe & the Middle East: Call +44(0)870-330-6101

For all other areas visit our website to find your nearest distributor.



Environmentally Responsible

Dealer: