

SEPAR FILTER



SWK2000, LKF and EVO10 Fuel Filter Catalogue

Rev1903

Separ UK, 3 Kingley Park, Station Road, Kings Langley, Herts, WD4 8GW
Tel: +44(0)1923 276007 Fax: +44(0)1923 267463
www.separ.co.uk sales@separ.co.uk



Content

Installation Instructions.....	4
Selecting a filter.....	5
SWK2000 range overview.....	6
SWK2000 Maintenance Instructions.....	8
Evo-10 range overview.....	9
Evo-10 Maintenance Instructions.....	10
LKF Maintenance Instructions.....	12
LKF 03 (Automotive).....	13
SWK2000/5 simplex.....	14
SWK2000/5U duplex.....	14
SWK2000/5/50 simplex.....	16
SWK2000/5/50U duplex.....	17
LKF 08 (Industrial).....	18
SWK2000/10 simplex.....	19
SWK2000/10 duplex.....	20
Evo-10 simplex truck and bus filter.....	21
SWK2000/18 simplex.....	22
SWK2000/18U duplex.....	23
SWK2000/40M simplex.....	24
SWK2000/40U duplex.....	25
SWK2000/40/2 double simplex.....	26
SWK2000/130 simplex.....	27
SWK2000/130U duplex.....	27
SWK2000/130/2 double simplex.....	28
SWK2000 Range Steel Filters (SOLAS).....	30
Active/Passive Water in Fuel Sensors.....	31
Hand Priming Pump.....	33
Vacuum gauge.....	34
Adjustable vacuum switch.....	35
Ordering procedure.....	36

The information contained in this catalogue is correct to the best of our knowledge; however always check with Separ UK for the precise data relating to any given product.

Occasionally products are updated or have subtle re-designs. Given we produce a catalogue ever year to eighteen months; it is not always possible to include these changes. Speaking to Separ UK is always the easiest way to ensure you have the latest information. Alternately you can visit our web site at www.separ.co.uk

Information in this document is for reference only, E&OE.

Note: The manufacturer reserves the right to change or amend specifications without notice.



SWK2000, LKF and Evo10 filter ranges catalogue rev1903

NOMINAL FLOW RATES

LKF03	= 3 l/min or 180 l/h
SWK 2000/5	= 5 l/min or 300 l/h
SWK 2000/5/50	= 5 l/min or 300 l/h
LKF08	= 8 l/min or 480 l/h
SWK 2000/10	= 10 l/min or 600 l/h
Evo-10	= 10 l/min or 600 l/h
SWK 2000/18	= 18 l/min or 1080 l/h
SWK 2000/40	= 40 l/min or 2400 l/h
SWK 2000/40/2	= 80 l/min or 4800 l/h
SWK 2000/130	= 130 l/min or 7800 l/h
SWK 2000/130/2	= 260 l/min or 15600 l/h

SWK2000 OPTIONS (letters shown after the /5 or /10 etc)

No letter	= Clear (Trogamid T5000) bowl
U	= Duplex, Switchable filter
D	= Clear bowl with heat shield
K	= Clear bowl with water alarm contacts
KD	= Clear bowl, heat shield, water alarm contacts
M	= Metal bowl
MK	= Metal bowl with contacts
B	= Gas/Petrol version (always metal bowl)
S	= Potential free probe for water level indication
H	= Heated filter 12v or 24v

Examples of the filter part numbers

Simplex Unit	Duplex Unit	Description	Nominal Flow rate	Port (simplex)	Port (duplex)
LKF03	-	Clear Bowl	3	M14 x 1.5	-
SWK2000/5	SWK2000/5/U	Clear bowl	5	M16 x 1.5	12 mm Pipe Ø / M18
SWK2000/5/50	SWK2000/5/50/U	Clear bowl	5	M16 x 1.5	12 mm Pipe Ø / M18
SWK2000/5/50/K	SWK2000/5/50/UK	Clear bowl. Contacts	5	M16 x 1.5	12 mm Pipe Ø / M18
SWK2000/5/50/D	SWK2000/5/50/UD	Clear bowl. Heat shield	5	M16 x 1.5	12 mm Pipe Ø / M18
SWK2000/5/50/KD	SWK2000/5/50/UKD	Clear bowl. Contacts. Heatshield	5	M16 x 1.5	12 mm Pipe Ø / M18
SWK2000/5/50/M	SWK2000/5/50/UM	Metal bowl	5	M16 x 1.5	12 mm Pipe Ø / M18
SWK2000/5/50/MK	SWK2000/5/50/UMK	Metal bowl. Contacts	5	M16 x 1.5	12 mm Pipe Ø / M18
SWK2000/5/50/H	SWK2000/5/50/UH	Clear bowl. Heated filter	5	M16 x 1.5	12 mm Pipe Ø / M18
SWK2000/5/50/MH	SWK2000/5/50/UMH	Metal bowl. Heated filter	5	M16 x 1.5	12 mm Pipe Ø / M18
LKF08	-	Clear Bowl	8	M16 x 1.5	-
Evo-10	-	Clear bowl. Lightweight filter	10	M16 x 1.5	12 mm Pipe Ø / M18
SWK2000/10	SWK2000/10/U	Clear bowl	10	M22 x 1.5	15 mm Pipe Ø / M22
SWK2000/10/K	SWK2000/10/UK	Clear bowl. Contacts	10	M22 x 1.5	15 mm Pipe Ø / M22
SWK2000/10/D	SWK2000/10/UD	Clear bowl. Heat shield	10	M22 x 1.5	15 mm Pipe Ø / M22
SWK2000/10/KD	SWK2000/10/UKD	Clear bowl. Contacts. Heat shield	10	M22 x 1.5	15 mm Pipe Ø / M22
SWK2000/10/M	SWK2000/10/UM	Metal bowl	10	M22 x 1.5	15 mm Pipe Ø / M22
SWK2000/10/MK	SWK2000/10/UMK	Metal bowl. Contacts	10	M22 x 1.5	15 mm Pipe Ø / M22
SWK2000/10/H	SWK2000/10/UH	Clear bowl. Heated filter	10	M22 x 1.5	15 mm Pipe Ø / M22
SWK2000/18	SWK2000/18/U	Clear bowl	18	M26 x 1.5	22 mm Pipe Ø / M30
SWK2000/18/K	SWK2000/18/UK	Clear bowl. Contacts	18	M26 x 1.5	22 mm Pipe Ø / M30
SWK2000/18/D	SWK2000/18/UD	Clear bowl. Heat shield	18	M26 x 1.5	22 mm Pipe Ø / M30
SWK2000/18/KD	SWK2000/18/UKD	Clear bowl. Contacts. Heatshield	18	M26 x 1.5	22 mm Pipe Ø / M30
SWK2000/18/M	SWK2000/18/UM	Metal bowl	18	M26 x 1.5	22 mm Pipe Ø / M30
SWK2000/18/MK	SWK2000/18/UMK	Metal bowl. Contacts	18	M26 x 1.5	22 mm Pipe Ø / M30
SWK2000/40/M	SWK2000/40/UM	Metal bowl	40	M33 x 2.0	35 mm Pipe Ø / M45
SWK2000/40/MK	SWK2000/40/UMK	Metal bowl. Contacts	40	M33 x 2.0	35 mm Pipe Ø / M45
SWK2000/40/MS	SWK2000/40/UMS	Metal bowl. Special water probe	40	M33 x 2.0	35 mm Pipe Ø / M45
SWK2000/40/2/MK	-	Metal bowl. Contacts	80	42 mm Pipe Ø	-
SWK2000/130/MK	SWK2000/130/UMK	Metal bowl. Contacts	130	2" BSP thread	2" BSP thread
SWK2000/130/MS	SWK2000/130/UMS	Metal bowl. Special water probe	130	2" BSP thread	2" BSP thread
SWK2000/130/2/MK	-	Metal bowl. Contacts	260	3" BSP thread	-

Tightening Torques

Filter range	Bowl	Lid	Port plug	WIF sensor	Bleed screw
LKF03 (and 08)	4 Nm	n/a	4 Nm	4 Nm	n/a
SWK2000/5	6 Nm	6 Nm	10 Nm	n/a	6 Nm
SWK2000/5/50	6 Nm	6 Nm	10 Nm	n/a	6 Nm
SWK2000/10	8 Nm	8 Nm	10 Nm	10 Nm	6 Nm
Evo-10	4 Nm	4 Nm	4 Nm	4 Nm	4 Nm
SWK2000/18	12 Nm	12 Nm	15 Nm	10 Nm	6 Nm
SWK2000/40	13 Nm	15 Nm	15 Nm	10 Nm	6 Nm
SWK2000/130	ca 20 Nm	ca 20 Nm	n/a	10 Nm	n/a

Installation Instructions

Filters should be installed on the suction side of the fuel system, between the fuel tank and the engine mounted fuel lift pump.

- Install the filter in an accessible position to allow water and particulate removal and filter element change (a minimum of 60 mm above the filter is required for element change for the SWK2000 range).
- The filter housing has two inlet and two outlet ports to give options for the ideal installation position.
- The ideal position for the filter is at the same height as the lift pump. However, if the top of the fuel tank is above this position a “full flow” ball valve should be fitted before the filter, so that the fuel flow can be shut off to allow filter maintenance.
- In applications where the fuel level is below the filter, it is still advisable to install a full flow ball valve to prevent fuel draining back into the fuel tank.
- After filter installation on system without a positive head of fuel, remove the filter lid and fill the filter with fuel to assist in priming the system.
- Avoid sharp 90-degree bends in the fuel system piping, as these increase pressure drop; as does any reduction in the internal diameter of fuel piping.
- Check all fittings are tight and free from leaks.

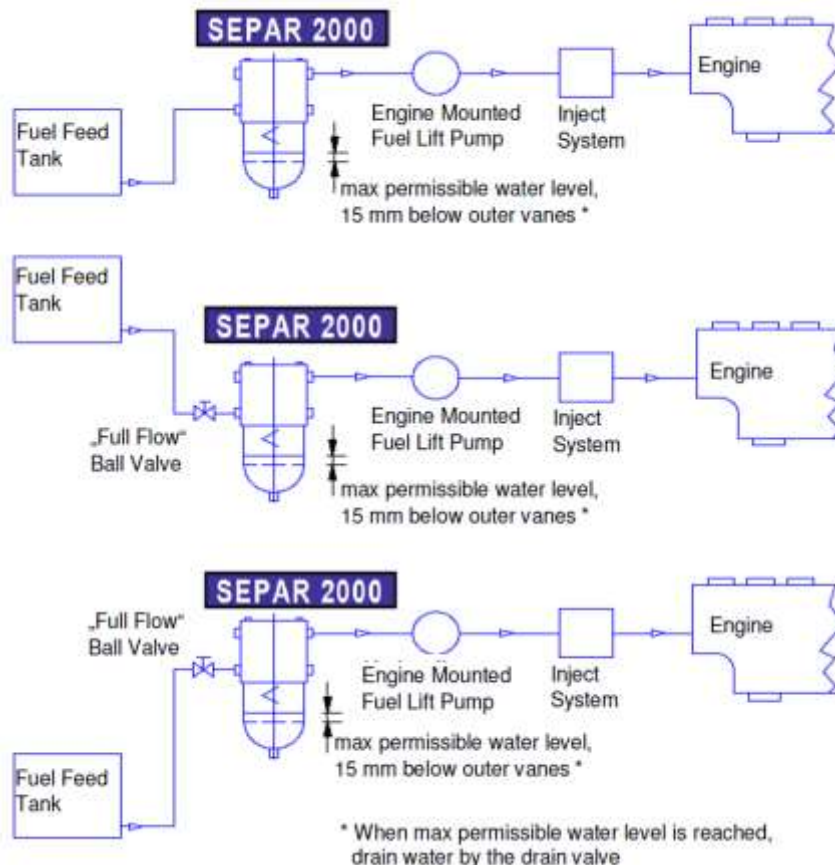

Selecting a filter

There are many different considerations when sizing the right filter for any given application. Whilst this list is not exhaustive, we would always want to consider the following factors.

- Is water separation needed?

If not, then a strainer or simple fuel filter may be enough, if it is then a specific water separator should be used.

- Maximum fuel flow rate

Often mistaken for fuel consumption, this figure is vital to selecting the right filter. The easiest way to get this figure is to find out the maximum capacity of your fuel transfer/lift pump. Whilst fuel consumption is important for any customer, the flow can be four times the consumption. Always select a filter with a capacity higher than or equal to the maximum fuel flow. The fuel flow can be lower than a filter's maximum capacity, but conversely selecting a filter which is too small for the flow rate will dramatically increase the pressure restriction.

- Restriction – Delta P

Fuel flow restriction or pressure restriction can be vital to some applications where the fuel pressure at the engine is closely monitored. The lower the delta P figure, the less restriction the filter will put into the fuel. In a transfer system it is typically less important.

- Marine or non-marine application?

Depending on the location of the fuel filter in question, different rules exist as to what materials can be used in its construction. For example, an ocean-going leisure craft must periodically have an RCD inspection (recreational craft directive), this states the fuel filters used must meet the fire-proofing standard ISO10088. Likewise, the British waterways expect the same requirement for all inland craft. This means one of our metal bowl units. Other applications such as generator or truck filters do not have such requirements and so standard clear bowl or clear bowl with heatshield filters can be used.

- Port sizes / pipe sizes

Not all customers need a specific flow rate; some just want to match to their existing pipe work dimensions. For example, a customer with a 2" pipe who only needs to strain fuel does not always want to throttle the pipe down to 1" to match the ideal filter. Separ UK offer a range of filter solutions to meet their needs, from a wide range of filters to match the specific requirement to a massive range of fittings to ensure compatibility to any standard pipe dimensions.

- Straining element size

What micron rating is required? If the application is for fuel in storage or as a pre-filter, then typically 30 micron is sufficient. What does that mean? 1 micron is one millionth of a meter, meaning there are 1000 microns in a millimetre. A human hair is typically 0.06mm (60 micron); 30 micron is therefore about half the width of an average human hair. Some customers need very fine straining, to 10, 5 or even lower micron ratings – some only need something coarse to stop large contaminants; in the region of 100, 300 or even 400 micron. Separ UK has the right filtration solution to match their requirements, and in most cases, the filter elements themselves can be changed at a later stage should the customer subsequently need to change their specification.

- Simplex or Duplex

Looking at a typical marine customer as an example, if they had two engines on their boat, they would need a simplex filter for each engine's fuel system. A simplex filter is one with a single body and a single path for the fuel to flow through. However, if the customer had a boat with a single engine, we would strongly recommend a duplex filter – this has two paths for the fuel to flow through, where only one is in use at any time. Should the customer experience fuel contamination in the twin engine boat, it is highly unlikely both fuel systems would block at the same time, in the single engine boat however; a simple movement of the duplex's changeover lever and the second flow path becomes live. The first path is now clear for servicing, without having to stop the engine.

Don't forget, the Separ filters contained in this brochure are suction side devices, so fuel should be drawn through them as opposed to being on the pressure side of the pump.

SWK2000 range overview

This range is an effective system for the separation of water and particulate from fuel. This is vital as both water and particulate matter can result in high wear and tear of fuel pumps and injectors, resulting in reduced reliability and expensive engine repairs.

The separation and filtration process happens in a unique and patented procedure, which is applied throughout all the range. The SEPAR SWK2000 series is especially effective due to its small physical size in relation to the effective flow rate.

The SEPAR SWK2000 should be installed on the suction side of the fuel system, between the fuel tank and the pump.

The fuel cleaning process: fuel enters the filter through either port **A** or **B** depending which is more convenient for installation and using the plug provided to seal off the unused port.

Stage 1

From the inlet port, fuel flows through the interior vane system which places a circular motion to the fuel. A static centrifuge effect removes heavy and medium particulate.

Stage 2

Still in the circular motion fuel reaches the bowl section, where due to this centrifugal motion water droplets and heavier particles (down to 30 microns in size) are forced to the wall of the bowl, eventually settling in the bottom (ready for draining at a later stage).

Stage 3

In this stage the fuel must pass the vane system positioned on the “outside” of the central housing. Due to the differing length of the vanes and the two-fold rapid change of fuel flow direction, smaller water droplets and finer particles will settle on the vanes. These particles agglomerate (collect) and when heavy enough fall to the bottom of the bowl. Already by this point in the filtration process, the majority of contaminants in the fuel have been separated.

Stage 4

Just below the filter element the cross-sectional flow area of the filter is increased significantly, thus reducing the fuel flow rate per square cm. This slowing effect allows even smaller water droplets and particulate to fall out of the fuel flow, settling on the inner surfaces of the housing. In turn, these form larger droplets which eventually fall into the bottom of the bowl by gravity.

Note: due to the described pre-separation process, most of the water and particulate present in the fuel will be ejected into the bowl or on the inner surfaces of the filter, thus greatly extending the filter element life.

Stage 5

The final filtration of the remaining water and particulate still contained in the fuel will be affected by a replaceable filter element. These filter elements are produced from a special filter media and are available in different pore sizes. The standard supply is 30 micron; however, both 10 and 60 micron are also available. The 60-micron element is made from stainless steel, and so with careful cleaning can be re-used.

The clean fuel leaves the filter via outlet ports **C** or **D** (the outlet port not required should be sealed with the plugs provided).

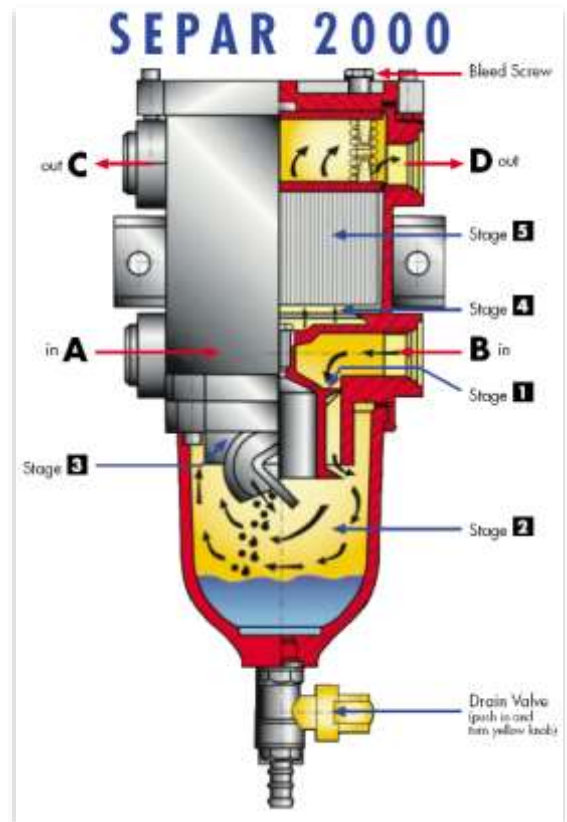



SWK2000, LKF and Evo10 filter ranges catalogue rev1903

Key Points for the range

- SWK2000 range filters are aluminium construction, apart from the steel versions. Evo-10 filters are polymer construction
- Available with various flow rates from 1 to 260 lit/min (60-15600 lit/hr) thereby offering fuel filters for engine performance ranges: 5 to 10,000kw.
- Standard for diesel and bio-diesel applications, with versions for petrol (petroleum) engines also available, please ask for details.
- Compact size, various port dimensions, simple installation, and high separation efficiency of water contained in the fuel. (No water shown acc. to RTÜV testing.)
- Due to the use of a back-flushing procedure, the SWK2000 filter can extend its service interval.
- The SWK2000 range protects the injection pump and injection nozzles from damage due to water and other contaminate.
- Easy maintenance.
- For cold ambient temperatures, SWK2000 filters are available with an effective heating system.
- Superior suction side primary filtration

Application areas

- Automotive industry - trucks, buses, mobile cranes, municipality vehicles etc.
- Stationary engines - generators, welding and pumping installations etc.
- Mining applications
- Construction equipment, compressor sets, agricultural equipment, fork lift trucks, etc
- Marine propulsion
For this application, duplex switchable filters are available.
An optional water level (water in fuel) sensor can be supplied.
- Special versions for certain applications are also available, please ask for details.

Tests and Certificates

- Rheinisch-Westfälischer TÜV
- Kraftfahrt-Bundesamt Flensburg
- German Technical Department for Army Ship and Marine Weapons
- RINA
- Germanischer Lloyd Type Approval Certificate
- Lloyd Type Approval Certificate
- Bureau Veritas Type Approval Certificate

Copies of these certificates can be downloaded from our website. Search for the “type approval” section. Please note, the above typically only applies to metal bowl units.

SWK2000, LKF and Evo10 filter ranges catalogue rev1903

SWK2000 Maintenance Instructions

Replace the filter element either if the pressure drop is too high, if engine is not able to reach maximum revs or at least once a year.

Important: Only clean diesel fuel should be used to clean clear plastic bowls, certain cleaning materials can attack the plastic material and have a detrimental effect

SWK2000 range filter element change

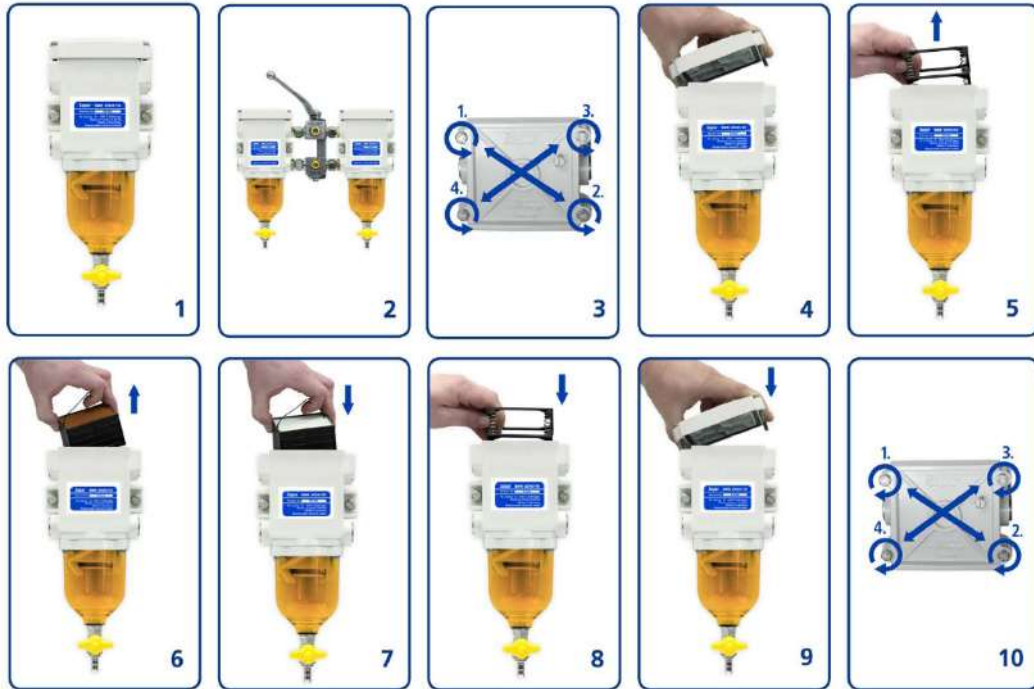

SWK2000 range water drain/backflush procedure

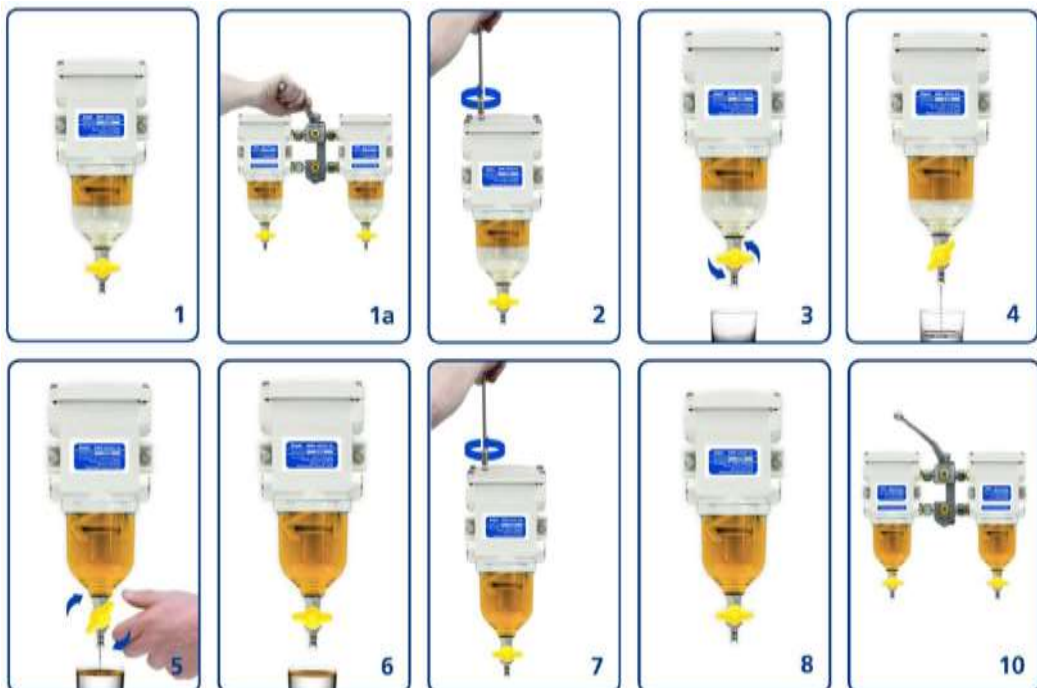

Evo-10 range overview

- High separation efficiency with minimal pressure drop
- Easy to install
- Service and environment friendly
- Optional heater and/or water sensor
- Compact design with minimal weight
- Suction side filtration

This range is an effective system for the separation of water and particulate from fuel. This is vital as both water and particulate matter can result in high wear and tear of fuel pumps and injectors, resulting in reduced reliability and expensive engine repairs.

How it Works

1. Fuel inlet
2. Rotational motion is induced in the fuel, while passing through the internal centrifugal chamber
3. The fuel exits the centrifuge system and enters the filter bowl
4. Due to the rotational energy, water and particulates separate from the fuel and settle at the bottom of the bowl
5. The fuel is guided to the vane separation chamber
6. The large cross section of the pre-chamber results in the fuel flow velocity being reduced allowing more particulate separation
7. Suspended particulates and the finest water droplets are caught in the pleated media of the filter element
8. The cleaned fuel passes to the outlet chamber
9. Fuel outlet

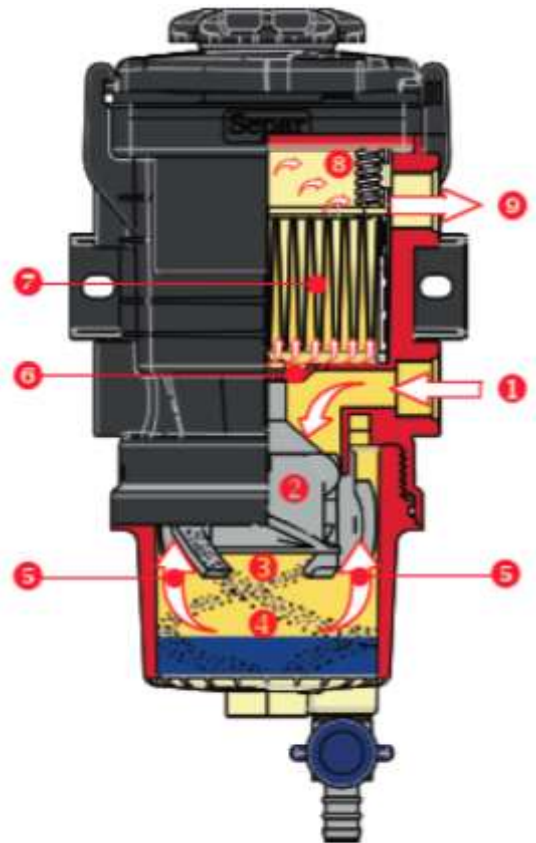





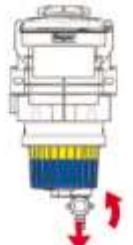

Evo-10 Maintenance Instructions

Evo-10 filter element change

						
Loosen the central tightening screw on the cover.	Turn it until it reaches the stop position.	Release the lid with pressure and rotate it left so that it is free of the bayonet, that it is free of the bayonet.	Remove the lid and the cover from the filter housing.	Remove the spring cassette.	Pull the filter element out of the housing using the handle.	Dispose of the used filter element responsibly (according to local regulations).
						
Insert the new filter element.	Replace the spring cassette.	Put the lid and cover back in position.	Reset the cover with a gentle downwards pressure and a turn to the right.	Check the correct location of the lid on the filter head.	Tighten the screw to a torque of 10 Nm.	Tighten the screw until it will securely lock.

Evo-10 filter water drain/backflush procedure

						
Loosen the bleed screw on the lid by two rotations.	Pull the handle of the drain valve towards you and open it by a quarter of turn to the left.	Release sufficient fluid so that the bowl is filled with diesel fuel only.		Close the drain valve by turning the handle to the right until it snaps in place.	Tighten the bleed valve on the lid so that it is air tight (a torque of 4 Nm). Prime the fuel system.	

LKF Filter Range Overview

- Industrial/Automotive filter
- Up to 8 lit/min
- Aluminium design
- Lightweight
- 10, 6 or 3 micron filtering
- 2 stage process
- Free/Emulsified Water and particulate removal
- Suction or pressure (up to 2bar) side
- Unique RFID security
- Special fuel return port
- Innovative self-heating
- Air venting port
- Optional sensors available
- All metric ports for greater compatibility



The LKF range is designed to be a suction side filter (before the fuel pump), however it has been tested up to 4 bar pressure. All LKF series filters have the same functionality.

Connections

The filter has three ports on each side, the function of which can be seen below. The draining of separated water is via a special drain plug on the filter's underside.

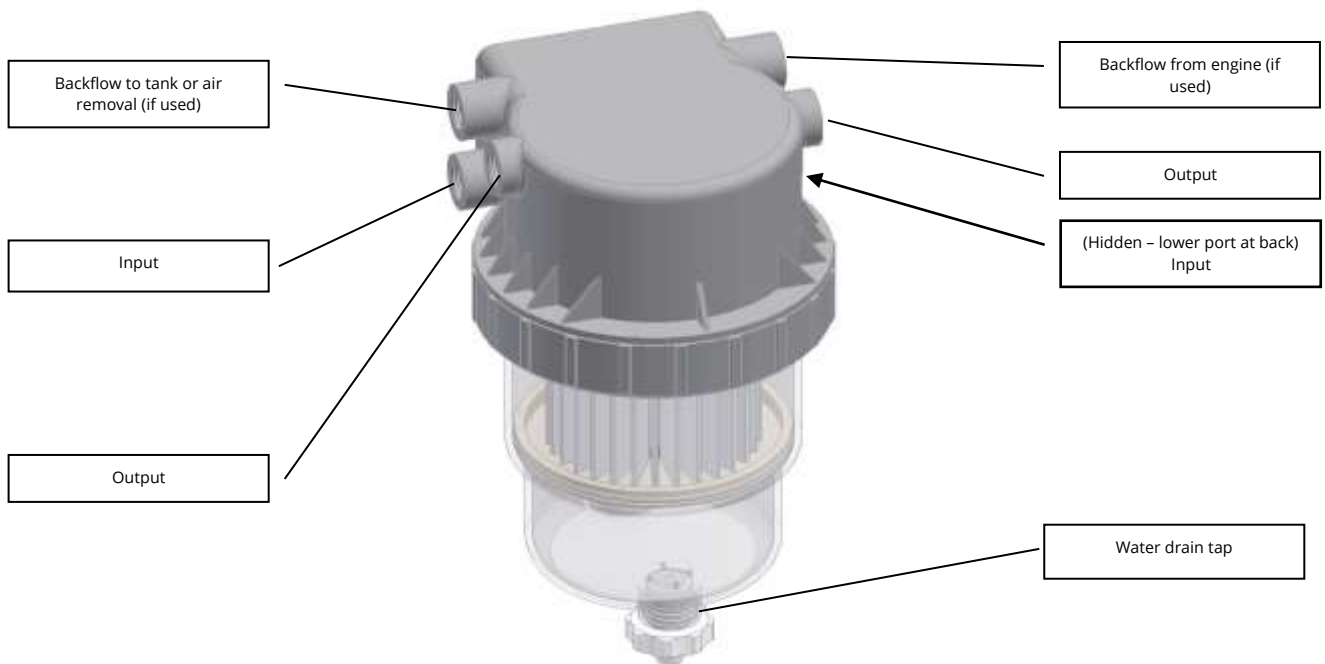

Filtering

The standard filter elements have two filter media. The external filter media is a special coalescence medium through which the water droplets are collected and grow to a point they can be securely separated on the inner, hydrophobic filter media. The separated water collects in the lower part of the filter bowl.

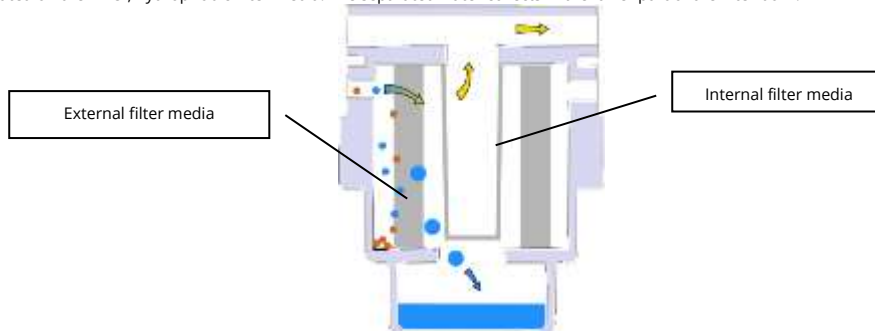

The fuel flow in modern common rail engines is far higher than the actual fuel consumption (burnt fuel). The service life of the filter element can be significantly increased by connecting the fuel return line from the engine to the filter, since this already filtered fuel is injected back into the filter (and in turn returned to the engine), a significantly smaller amount fuel is needed from the tank.

SWK2000, LKF and Evo10 filter ranges catalogue rev1903

LKF Heating

All filters can be equipped with an external heating element, which is mounted upstream of the filter. The heater can be up to 600 W.

The fuel returned from the engine is usually far warmer than the fuel in the tank. This available heat, which is a significantly higher temperature than an external device can produce, can be used for heating. To utilise this feature, the engine's fuel return line is connected to the filter, exactly as described in section 1.2.

LKF Air venting

Air dissolved in fuel can be unbonded by passing over sharp edges or tight bends, in turn this can cause pressure variations in the engine. If these air bubbles occur in the filter, they collect at the highest point. The air venting connections can be used, along with an external pump-off device, to extract any air during operation.

LKF Water drainage

The separated water is visible through the transparent bowl; however, should the metal bowl be used or should the operator require an external signal, an optional water sensor can also be used (e.g. for vehicle, PLC, buzzer, beacon notification, etc).

Separated water is removed simply and cleanly via the special drain tap.

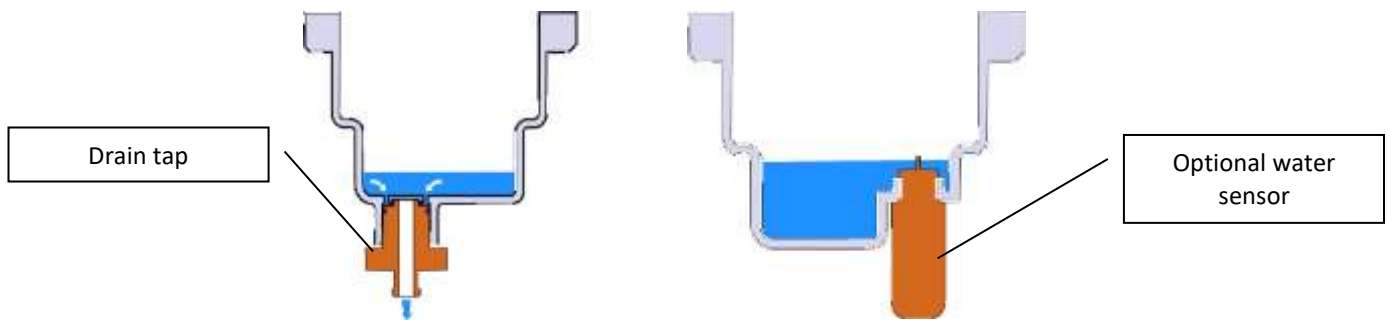

LKF Identification

Every filter and every filter element is uniquely identified and hence secure against forgery via a RFID transponder in the filter lid.

For added security, this transponder can also be read when the filter is dirty or has been painted.

In the future, it is envisaged this will allow OEMs to check their filters and ensure only original parts are used.

Furthermore, the use of QR codes on the filter body allows the user to quickly download datasheets and service instructions from the internet.



LKF Maintenance Instructions

Draining water

- Stop the flow of fuel to the engine
- Isolate the filter from the fuel supply if possible
- Place a suitable container under the water drain tap
- Slightly unscrew the water drain tap on the bottom of the filter
- If possible, open an air bleed valve or one of the unused ports on the filter top to allow air in, and hence let the water out
- Once fuel emerges, close the drain tap
- Re-tighten any valves opened to allow air in
- Open all isolating ball valves
- Re-prime if necessary
- Dispose of the waste water in accordance with local environmental rules

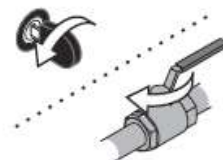

Stop machine or close supply pipe



Empty filter

Changing the filter element

- Stop the flow of fuel to the engine
- Isolate the filter from the fuel supply if possible
- Place a suitable container under the filter assembly to catch any fuel which may seep out
- Grab the central bowl ring and rotate it ¼ turn anticlockwise to unscrew it
- This is a bayonet ring and does not need to be rotated more than ½ a turn
- If it cannot be moved by hand, gently use a rubber strap wrench to loosen the ring. Do not use a metal tool
- Once the ring has been removed the bowl and element will be accessible
- Carefully remove the old element from the bowl
- Inset a new element, with the large O-ring edge at the bottom and the smaller proud O-ring end at the top. This element sits tightly inside the bowl
- Place the bowl/element back onto the filter head, there are locating lugs to ensure it lines up
- Re-attached the bowl ring and tighten it ¼ to ½ a turn. Do not over tighten
- Open all isolating ball valves
- Re-prime if necessary



Disassemble container



Dispose of used filter element and insert new filter element



Assemble container

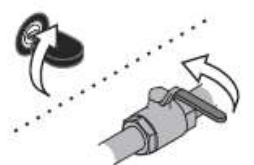

Start machine or open supply pipe

LKF 03 (Automotive)

	Metric	Imperial
Max Flow	3 Litres/Min	0.66 Gallons/Min
Max Flow	180 Litres/Hour	40 Gallons/Hour
Water Separation	>95%	
Water holding capacity	70ml	
Port Size	M14 x 1.5	
Filter restriction at Max Flow 10mic element	50 mBar	1.47 In.Hg
Width	108 mm	4.25 in
Height	177 mm	7 in
Element removal	67 mm	2.6 in
Total height needed	244 mm	9.6 in
Depth	116 mm	4.6 in
Weight	>1 Kg	2.2 Lbs

- Industrial/Automotive filter
- Polymer design
- Lightweight
- Free/Emulsified water removal
- Innovative self-heating
- Optional sensors available
- Optional in-line heater



Max fuel flowrate	3 l/min approx.	
Pressure/Vacuum (ref to ambient)	Continuous -0.8bar to +5bar	Maximum 6bar for less than 15 seconds
Separation process	Water	Coalescence media and hydrophobic water blocking
	Solid matter	Mechanical filter media and sedimentation upstream of the filter element
Filter surface area	80,000 mm ² approx.	
Replacement filter elements	10µm, 6µm or 3µm	
Degree of water separation	> 95% (ISO/TS 16332)	
Differential pressure on the filter	< 500 mbar	EN590 at 3 l/min, 20°C temperature
Dimensions (approx.)	108mm Width	
	116mm Depth	
	177mm Height	
	240mm Total height, allows space for water drain and servicing	
Weight	0.5 kg	Plastic model (Glass-fibre-reinforced PA)
Temperature range	-40 °C ... +85 °C	
Port sizes (input/output)	M14 x 1.5 ISO9974-1	15mm thread length, tightening torque 15Nm
Fixing (read of filter head)	2 x M8	Optional M8 bolts, internal screw-threads or link plates with 8.5 mm bore.
Fuel heating	Internal	Use excess heat from fuel return flow
	External (optional)	Separate controlled fuel heater, 600 W
Water separation capacity	ca. 70 ml	
Water alarm at	ca. 60 ml	
Sensor technology	Active water in fuel (PG7 thread)	
(optional, all with separate sensors)	Filter life	Temperature

Models

LKF03PN10	3 lit/min LKF filter c/w 10-micron element
LKF03PW10	3 lit/min LKF filter c/w water in fuel sensor and 10-micron element
LKF03PN03	3 lit/min LKF filter c/w 6-micron element
LKF03PW06	3 lit/min LKF filter c/w water in fuel sensor and 6-micron element
LKF03PN03	3 lit/min LKF filter c/w 3-micron element
LKF03PW03	3 lit/min LKF filter c/w water in fuel sensor and 3-micron element

Elements

LKF03ELE03	3-micron replacement element with gaskets
LKF03ELE06	6-micron replacement element with gaskets
LKF03ELE10	10-micron replacement element with gaskets

Spare Parts

LKF03-SealKit	Seal kit, containing 2x drain valve o-rings and 1x bowl o-ring
LKF03-ClampRing	Locking bowl (bayonet) ring
LKF03-BowlValve	Polymer bowl with drain valve

10381	Active water in fuel sensor with AMP plug (male)
10834	Mating AMP connector (female) for active sensor
30681	Sealing plug M14x1.5 with flat seal (input/output ports)
10558	Sealing plug for PG7 (water in fuel sensor port)

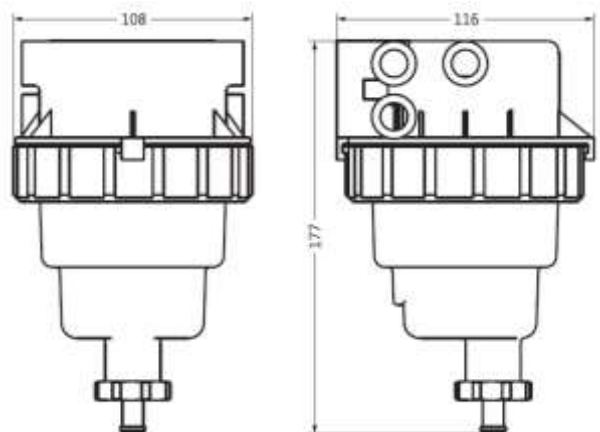

SWK2000/5 simplex

	Metric	Imperial
Max Flow	5 Litres/Min	1.1 Gallons/Min
Max Flow	300 Litres/Hour	66 Gallons/Hour
Water Separation	>99% of free water	
Water holding capacity	75ml	
Port Size	M16 x 1.5 ISO6149-1	
Filter restriction at Max Flow 30mic element	15 mBar	0.44 In.Hg
Width	140 mm	5.5 in
Height	246 mm	10 in
Element removal	30 mm	1.5 in
Total height needed	304 mm	12 in
Depth	94 mm	3.7 in
Weight	1.4 Kg	3 Lbs

Item	Part No	Description
1	30541	Aluminium Filter Housing
2	30542	Aluminium Filter Lid
3	10367	Lid Gasket*
4	30295	Spring Cassette
5	00530	Filter Element***
6	30564	Bowl Retaining Ring
7	10366	Bowl Gasket*
8	8x 30447	Washer 5.3
9	4x 30430	Lid Screw
10	4x 30561	Bowl Ring Screw
11	30984	Bowl (clear)**
12	10360	Drain Valve Gasket*
13	30366-1	Drain Valve
14	30408	Bleed Screw
15	30558	Bleed Screw Gasket*
16	2x 30471	Port Plug
17	2x 10360	Port Plug Gasket*

* Part of gasket kit (part 10527)

** Clear bowl shown, but others are available. Metal bowl units have ISO10088.

Plastic bowl	30984
Plastic bowl with alarm contacts	30984k
Metal bowl	30981
Metal bowl with alarm contacts	30981k
Plastic bowl, heat-shield	30988
Plastic bowl, heat-shield with alarm contacts	30994

*** This is the 30 micron element and it is the default option, but others are available

10 micron	00510 (paper)
30 micron	00530 (paper)
60 micron	00560s (stainless steel)

Water in fuel sensing options are available for this filter.

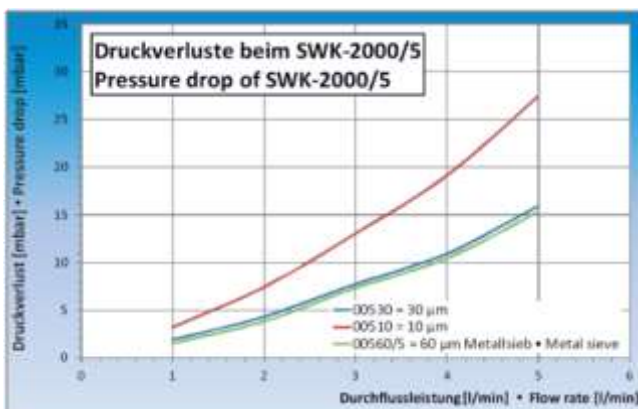
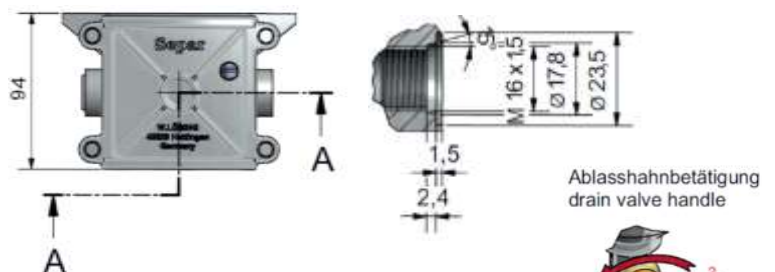
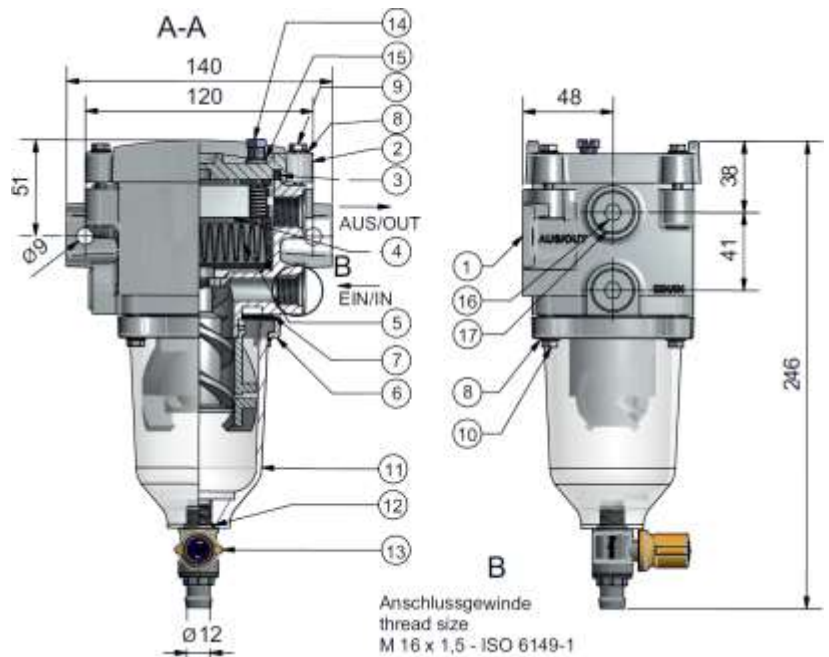

Popular part numbers
 SWK2000/5M (metal bowl)
 SWK2000/5MK (metal bowl with water in fuel sensing points)
 SWK2000/5KD (clear bowl with metal heat shield and sensing points)

SWK2000/5U duplex

	Metric	Imperial
Max Flow	5 Litres/Min	1.1 Gallons/Min
Max Flow	300 Litres/Hour	66 Gallons/Min
Filter restriction at Max Flow 30mic element	20 mBar	0.59 in.Hg
Port Size	12 mm pipe (M18x1.5)****	
Water holding capacity	75ml per side	
Width	440 mm	17.32 in
Height	298 mm	11.75in
Element removal	30 mm	1.5 in
Total height needed	298 mm	13.25 in
Depth	160 mm	6.3 in
Weight	4.5 Kg	10 Lbs.

Item	Part No	Description
1	2x 30541	Aluminium Filter Housing
2	2x 30542	Aluminium Filter Lid
3	2x 10367	Lid Gasket*
4	2x 30295	Spring Cassette
5	2x 00530	Filter Element***
6	2x 30564	Bowl Retaining Ring
7	2x 10366	Bowl Gasket*
8	16x 30447	Washer 5.3
9	8x 30430	Lid Screw
10	8x 30561	Bowl Ring Screw
11	2x 30984	Bowl (clear)**
12	2x 10360	Drain Valve Gasket*
13	2x 30366-1	Drain Valve
14	2x 30408	Bleed Screw
15	2x 30558	Bleed Screw Gasket*
16	4x 30471	Port Plug
17	4x 10360	Port Plug Gasket*
18	10215	Changeover handle
19	2x 30250	Cutting Ring (olive)****
20	2x 30249	Union nut****

NB. Please refer to SWK2000/5 simplex for height dimension and additional parts

* Part of gasket kit (part 10527). 2 of these kits are required for a full service of this duplex filter

** Clear bowl shown, please refer to the SWK2000/5 simplex for other bowl options

*** This is the 30 micron element and it is the default option, but others are available

10 micron	00510 (paper)
30 micron	00530 (paper)
60 micron	00560s (stainless steel)

NB, there is one filter element in each side of this duplex assembly

****If the nut and olive are removed from the filter, a male M18x1.5 thread is exposed for alternative connection options

Water in fuel sensing options are available for this filter.

The changeover handle is always over the active side of the duplex filter assembly. There is no middle position.

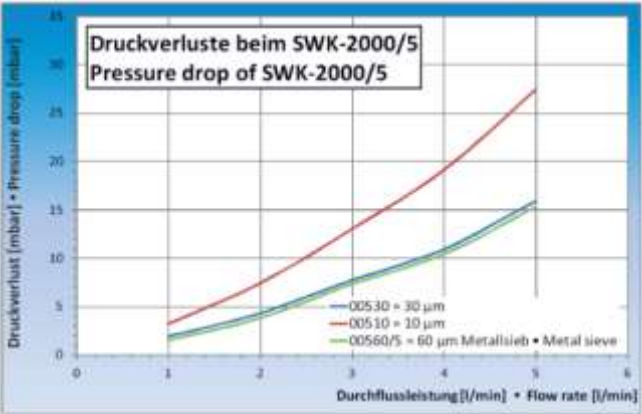
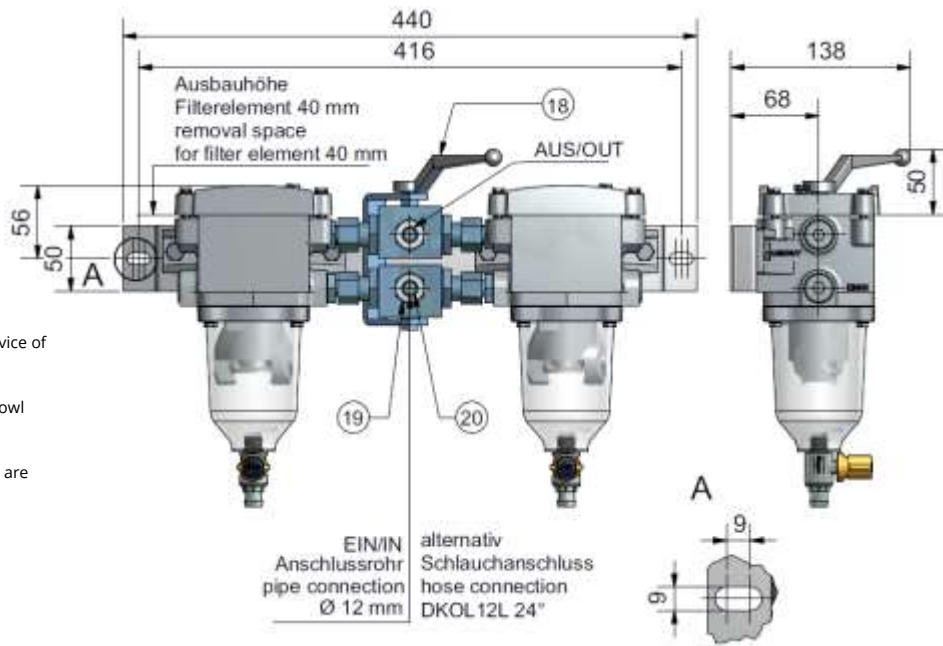

Popular part numbers
 SWK2000/5UM (metal bowl)
 SWK2000/5UMK (metal bowl with water in fuel sensing points)
 SWK2000/5UKD (clear bowl with metal heat shield and sensing points)

SWK2000/5/50 simplex

	Metric	Imperial
Max Flow	5 Litres/Min	1.1 Gallons/Min
Max Flow	300 Litres/Hour	66 Gallons/Hour
Water Separation	>99% of free water	
Water holding capacity	75ml	
Port Size	M16 x 1.5 ISO6149-1	
Filter restriction at Max Flow 30mic element	18 mBar	0.53 In.Hg
Width	140 mm	5.5 in
Height	283 mm	11.1 in
Element removal	30 mm	3 in
Total height needed	356 mm	14 in
Depth	94 mm	3.7 in
Weight	1.4 Kg	4 Lbs

Item	Part No	Description
1	10170	Aluminium Filter Housing
2	30542	Aluminium Filter Lid
3	10367	Lid Gasket*
4	30296	Spring Cassette
5	00530/50	Filter Element***
6	30564	Bowl Retaining Ring
7	10366	Bowl Gasket*
8	8x 30447	Washer 5.3
9	4x 30430	Lid Screw
10	4x 30561	Bowl Ring Screw
11	30984	Bowl (clear)**
12	10360	Drain Valve Gasket*
13	30366-1	Drain Valve
14	30408	Bleed Screw
15	30558	Bleed Screw Gasket*
16	2x 30471	Port Plug
17	2x 10360	Port Plug Gasket*

* Part of gasket kit (part 10527)

** Clear bowl shown, please refer to SWK2000/5 simplex for other options

*** This is the 30 micron element and it is the default option, but others are available

10 micron	00510/50 (paper)
30 micron	00530/50 (paper)
60 micron	00560/50s (stainless steel)

A 12v or 24v DC heated version of this filter is available on request.

Water in fuel sensing options are available for this filter.

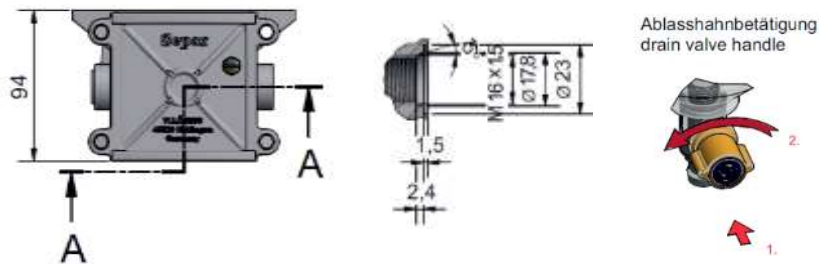
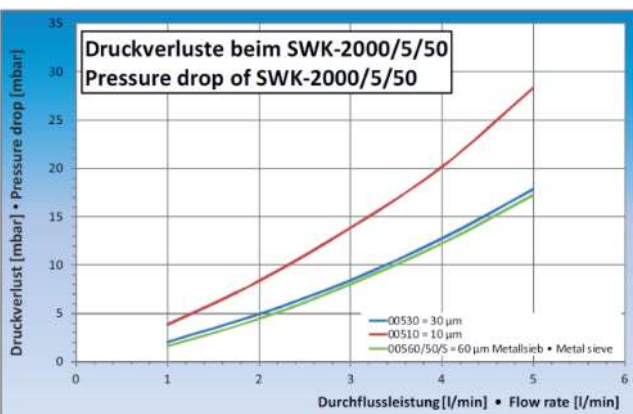
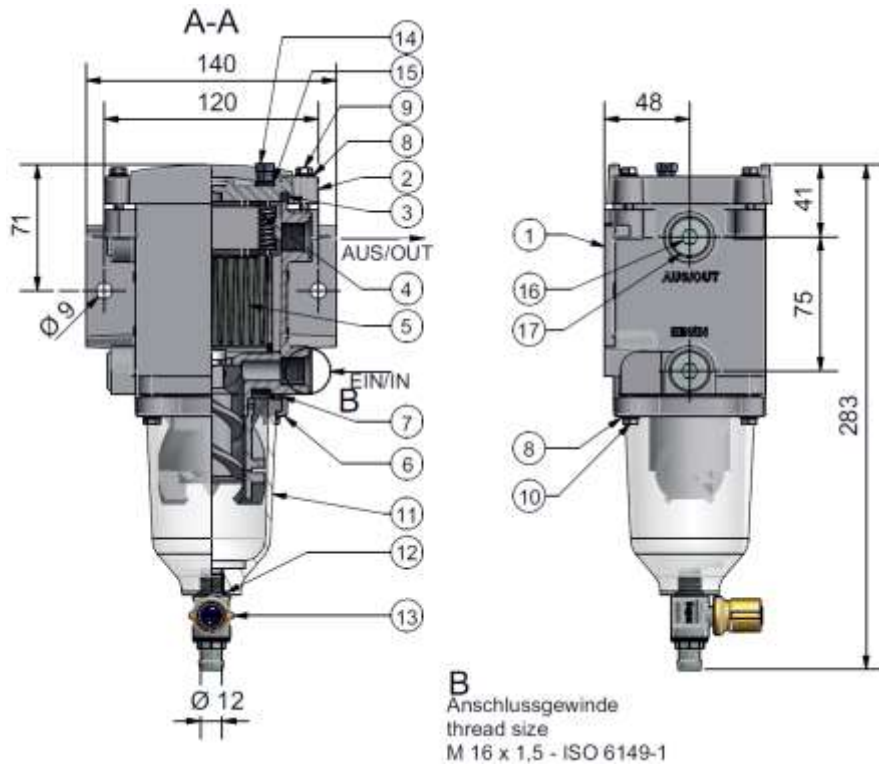

Popular part numbers
 SWK2000/5/50M (metal bowl)
 SWK2000/5/50MK (metal bowl with water in fuel sensing points)

SWK2000/5/50U duplex

	Metric	Imperial
Max Flow	5 Litres/Min	1.1 Gallons/Min
Max Flow	300 Litres/Hour	66 Gallons/Hr
Filter restriction at Max Flow 30mic element	18 mBar	0.53 In.Hg
Port Size	12 mm pipe (M18x1.5)****	
Water holding capacity	75ml per side	
Width	440 mm	17.3 in
Height	333 mm	13.1 in
Element removal	30 mm	3 in
Total height needed	356 mm	14 in
Depth	160 mm	6.3 in
Weight	5 Kg	10 Lbs

Item	Part No	Description
1	2x 10170	Aluminium Filter Housing
2	2x 30542	Aluminium Filter Lid
3	2x 10367	Lid Gasket*
4	2x 30296	Spring Cassette
5	2x 00530/50	Filter Element***
6	2x 30564	Bowl Retaining Ring
7	2x 10366	Bowl Gasket*
8	16x 30447	Washer 5.3
9	8x 30430	Lid Screw
10	8x 30561	Bowl Ring Screw
11	2x 30984	Bowl (clear)**
12	2x 10360	Drain Valve Gasket*
13	2x 30366-1	Drain Valve
14	2x 30408	Bleed Screw
15	2x 30558	Bleed Screw Gasket*
16	4x 30471	Port Plug
17	4x 10360	Port Plug Gasket*
18	10215	Changeover handle
19	2x 30250	Cutting Ring (olive)****
20	2x 30249	Union nut****

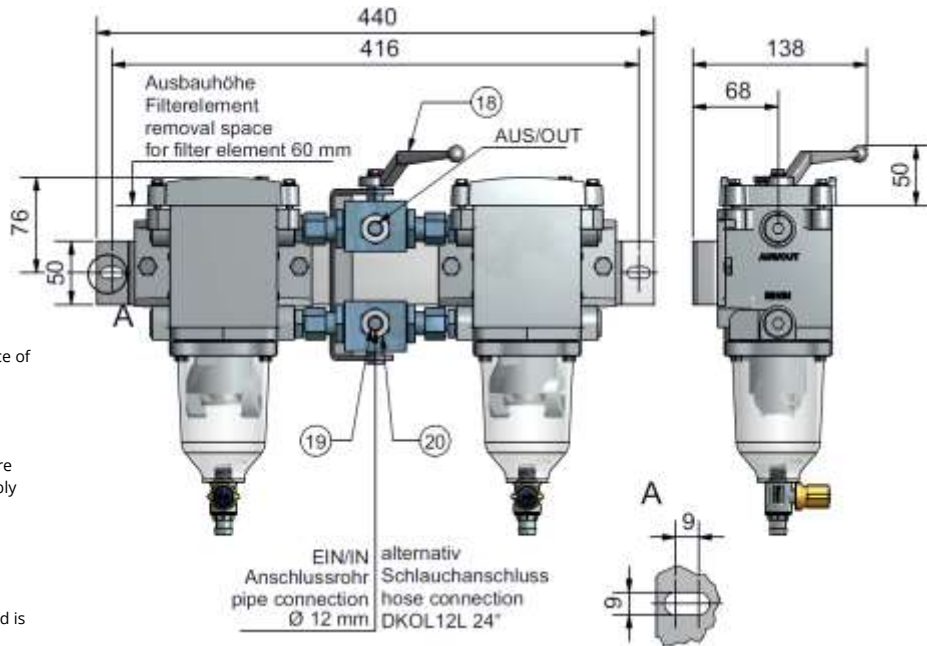

NB. Please refer to SWK2000/5/50 simplex for height dimension and additional parts

* Part of gasket kit (part 10527). 2 of these kits are required for a full service of this duplex filter

** Clear bowl shown, please refer to SWK2000/5 simplex for other options

*** This is the 30 micron element and it is the default option, but others are available. NB, there is one filter element in each side of this duplex assembly

10 micron	00510/50 (paper)
30 micron	00530/50 (paper)
60 micron	00560/50s (stainless steel)

****If the nut and olive are removed from the filter, a male M18x1.5 thread is exposed for alternative connection options

A 12v or 24v DC heated version of this filter is available on request.

Water in fuel sensing options are available for this filter. Also potential-free water in fuel sensing is available on this filter.

The changeover handle is always over the active side of the duplex filter assembly. There is no middle position.

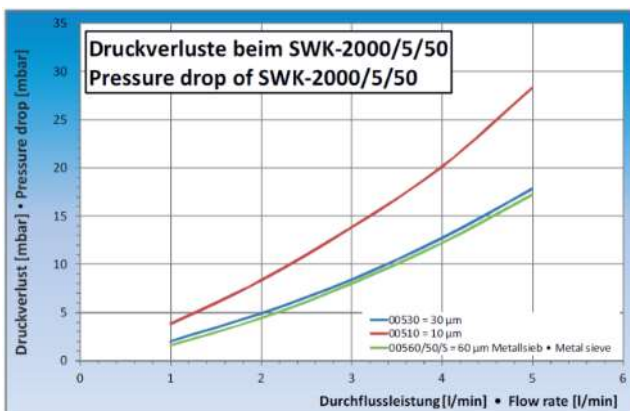

Popular part numbers
 SWK2000/5/50UM (metal bowl)
 SWK2000/5/50UMK (metal bowl with water in fuel sensing points)

LKF 08 (Industrial)

	Metric	Imperial
Max Flow	8 Litres/Min	1.75 Gallons/Min
Max Flow	480 Litres/Hour	105 Gallons/Hour
Water Separation	>95%	
Water holding capacity	70ml	
Port Size	M16 x 1.5	
Filter restriction at Max Flow 10mic element	50 mBar	1.47 In.Hg
Width	145 mm	5.6 in
Height	244 mm	9.6 in
Element removal	100 mm	3.9 in
Total height needed	344 mm	13.5 in
Depth	158 mm	6.2 in
Weight	1.3 Kg	2.8 Lbs

- Industrial/Automotive filter
- Polymer design
- Lightweight
- Free/Emulsified water removal
- Innovative self-heating
- Optional sensors available
- Optional in-line heater



Max fuel flowrate	8 l/min approx.	
Pressure/Vacuum (ref to ambient)	Continuous -0.8bar to +1.5bar	Maximum 2bar for less than 15 seconds
Separation process	Water Solid matter	Coalescence media and hydrophobic water blocking Mechanical filter media and sedimentation upstream of the filter element
Filter surface area	170,000 mm ² approx.	
Replacement filter elements	10µm, 6µm or 3µm	
Degree of water separation	> 95% (ISO/TS 16332)	
Differential pressure on the filter	< 500 mbar	EN590 at 3 l/min, 20°C temperature
Dimensions (approx.)	145mm Width 158mm Depth 244mm Height 344mm Total height, allows space for water drain and servicing	
Weight	1.3 kg	Plastic model (Glass-fibre-reinforced PA)
Temperature range	-40 °C ... +85 °C	
Port sizes (input/output)	M16 x 1.5 ISO9974-1	15mm thread length, tightening torque 15Nm
Fixing (read of filter head)	2 x M8	Optional M8 bolts, internal screw-threads or link plates with 8.5 mm bore.
Fuel heating	Internal External (optional)	Use excess heat from fuel return flow Separate controlled fuel heater, 600 W
Water separation capacity	ca. 200 ml	
Water alarm at	ca. 160 ml	
Sensor technology (optional, all with separate sensors)	Active water in fuel (PG7 thread) Filter life Temperature	

Models

LKF08PN10	8 lit/min LKF filter c/w 10-micron element
LKF08PW10	8 lit/min LKF filter c/w water in fuel sensor and 10-micron element
LKF08PN03	8 lit/min LKF filter c/w 6-micron element
LKF08PW06	8 lit/min LKF filter c/w water in fuel sensor and 6-micron element
LKF08PN03	8 lit/min LKF filter c/w 3-micron element
LKF08PW03	8 lit/min LKF filter c/w water in fuel sensor and 3-micron element

Elements

LKF08ELE03	3-micron replacement element with gaskets
LKF08ELE06	6-micron replacement element with gaskets
LKF08ELE10	10-micron replacement element with gaskets

Spare Parts

LKF08-SealKit	Seal kit, containing 2x drain valve o-rings and 1x bowl o-ring
LKF08-ClampRing	Locking bowl (bayonet) ring
LKF08-BowlValve	Polymer bowl with drain valve

10381	Active water in fuel sensor with AMP plug (male)
10834	Mating AMP connector (female) for active sensor
10558	Sealing plug for PG7 (water in fuel sensor port)

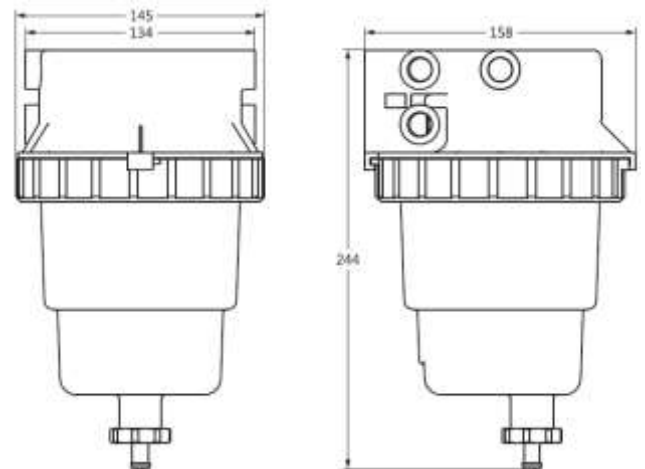

SWK2000/10 simplex

	Metric	Imperial
Max Flow	10 Litres/Min	2.2 Gallons/Min
Max Flow	600 Litres/Hour	132 Gallons/Hr
Filter restriction at Max Flow 30mic element	11 mBar	0.31 In.Hg
Water holding capacity	125ml	
Port Size	M22x1.5 ISO6149-1	
Width	146 mm	5.75 in
Height	313 mm	13 in
Element removal	60 mm	3 in
Total height needed	406 mm	16 in
Depth	146 mm	4.21 in
Weight	2.3 Kg	5 Lbs.

Item	Part No	Description
1	30552	Aluminium Filter Housing
2	30553	Aluminium Filter Lid
3	10362	Lid Gasket*
4	30297	Spring Cassette
5	01030	Filter Element***
6	30569	Bowl Retaining Ring
7	10361	Bowl Gasket*
8	8x 30448	Washer 5.3
9	4x 30567	Lid Screw
10	4x 30568	Bowl Ring Screw
11	30985	Bowl (clear)**
12	10360	Drain Valve Gasket*
13	30366-1	Drain Valve
14	30408	Bleed Screw
15	30558	Bleed Screw Gasket*
16	2x 30226	Port Plug
17	2x 10359	Port Plug Gasket*

* Part of gasket kit (part 10528)

** Clear bowl shown, but metal versions are also available. These have ISO10088

Plastic bowl	30985
Plastic bowl with alarm contacts	30985k
Metal bowl	30982
Metal bowl with alarm contacts	30982k
Plastic bowl, heat-shield	30989
Plastic bowl, heat-shield, with alarm contacts	30995

*** This is the 30 micron element and it is the default option, but others are available

10 micron - 01010 (paper)
30 micron - 01030 (paper)
60 micron - 01060s (stainless steel - washable)

On special request, a 30 micron stainless steel element can be produced. Part no 01030s

A 12v or 24v DC heated version of this filter is available on request.

Water in fuel sensing options are available for this filter. Also potential-free water in fuel sensing is available on this filter.

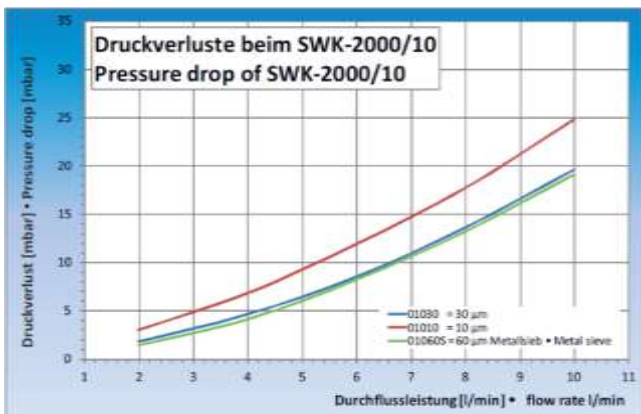
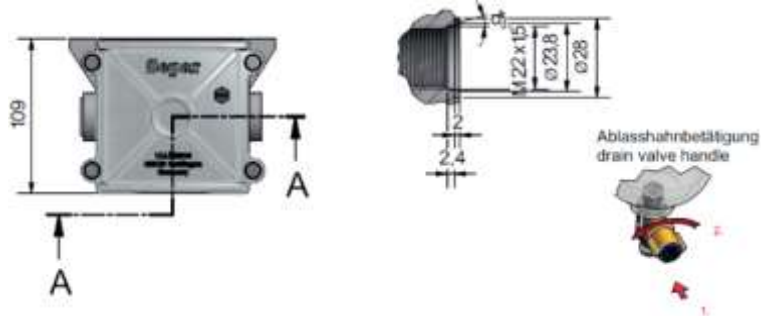
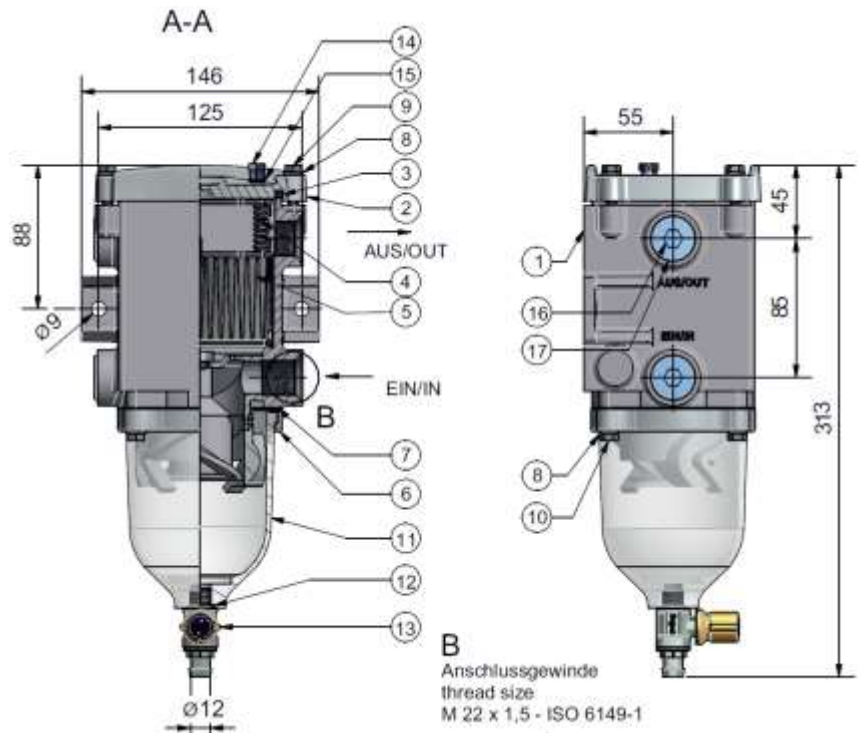

Popular part numbers
 SWK2000/10M (metal bowl)
 SWK2000/10MK (metal bowl with water in fuel sensing points)
 SWK2000/10KD (clear bowl with metal heat shield and sensing points)
 SWK2000/10MC (metal bowl with PG7 thread for water in fuel sensor)

SWK2000/10 duplex

	Metric	Imperial
Max Flow	10 Litres/Min	2.2 Gallons/Min
Max Flow	600 Litres/Hour	132 Gallons/Hr
Filter restriction at Max Flow 30mic element	11 mBar	0.31 In.Hg
Port Size	15mm nut/olive (M22x1.5)****	
Water holding capacity	125ml per side	
Width	460 mm	18 in
Height	378 mm	15 in
Element removal	60 mm	3 in
Total height needed	406 mm	16 in
Depth	194 mm	7.6 in
Weight	8.2 Kg	18 Lbs.

Item	Part No	Description
1	2x 30552	Aluminium Filter Housing
2	2x 30553	Aluminium Filter Lid
3	2x 10362	Lid Gasket*
4	2x 30297	Spring Cassette
5	2x 01030	Filter Element***
6	2x 30569	Bowl Retaining Ring
7	2x 10361	Bowl Gasket*
8	16x 30448	Washer 5.3
9	8x 30567	Lid Screw
10	8x 30568	Bowl Ring Screw
11	2x 30985	Bowl (clear)**
12	2x 10360	Drain Valve Gasket*
13	2x 30366-1	Drain Valve
14	2x 30408	Bleed Screw
15	2x 30558	Bleed Retaining Gasket*
16	4x 30226	Port Plug
17	4x 10359	Port Plug Gasket*
18	10216	Changeover Handle
19	2x 30248	Cutting Ring (olive)****
20	2x 30247	Union Nut****

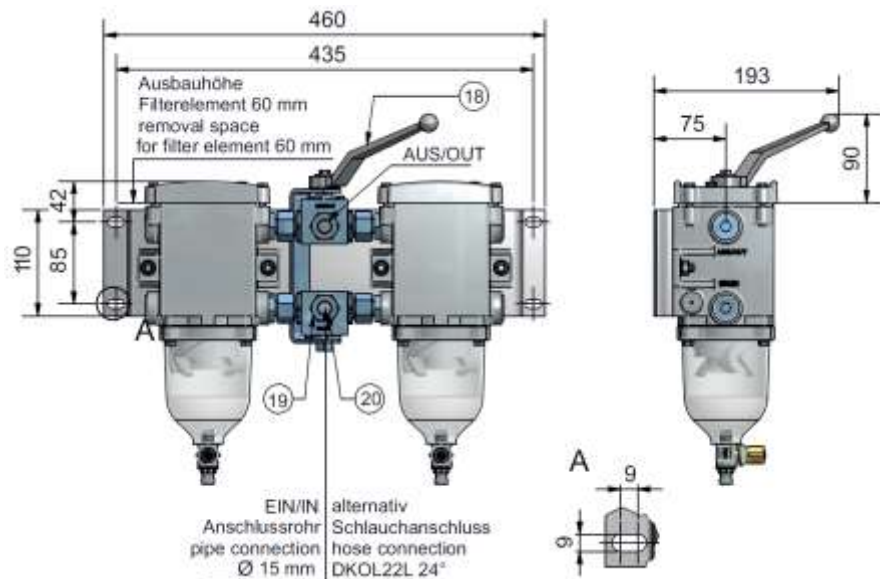

NB. Please refer to SWK2000/10 simplex for height dimension and additional parts

* Part of gasket kit (part 10528). 2 of these kits are required for a full service of this duplex filter

** Clear bowl shown, please refer to SWK2000/10 simplex for options

*** This is the 30 micron element and it is the default option, but others are available. NB, there is one filter element in each side of this duplex assembly

- 10 micron - 01010 (paper)
- 30 micron - 01030 (paper)
- 60 micron - 01060s (stainless steel - washable)

On special request, a 30 micron stainless steel element can be produced. Part no 01030s

****If the nut and olive are removed from the filter, a male M22x1.5 thread is exposed for alternative connection options

A 12v or 24v DC heated version of this filter is available on request.

Water in fuel sensing options are available for this filter.

The changeover handle is always over the active side of the duplex filter assembly. There is no middle position.

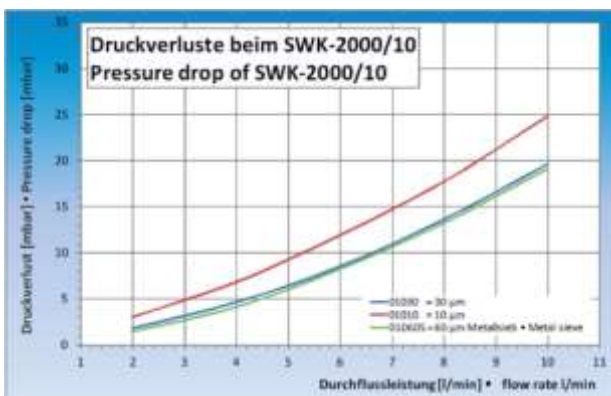

Popular part numbers
 SWK2000/10UM (metal bowl)
 SWK2000/10UMK (metal bowl with water in fuel sensing points)

Evo-10 simplex truck and bus filter

	Metric	Imperial
Max Flow	10 Litres/Min	2.2 Gallons/Min
Max Flow	600 Litres/Hour	132 Gallons/Hr
Filter restriction at Max Flow 30mic element	22 mBar	0.62 In.Hg
Port Size	M22x1.5 ISO6149-1	
Material	PA6 6GF50	
Width	140 mm	5.5 in
Height	300mm	12in
Element removal	30mm	1.25 in
Total height needed	330 mm	13.25 in
Depth	142 mm	5.56 in
Weight	1.1 KG.	2.4 Lbs.

Item	Part No	Description
1	10531	Polymer Filter Housing
2	10532	Polymer Filter cover
3	01030	Filter Element***
4	10559	Lid Gasket*
5	10537	Spring Cassette
6	10542	Clear Bowl**
7	10543	Bowl Gasket*
8	10398	Two Hole Nut
9	10544	Drain Valve
10	30558	Bleed Valve Gasket*
11	30408	Bleed Valve
12	10359	O Ring*
13	10234	Port Plug
14	10609	Lid Dust Cover

* Part of gasket kit (part 10634)

** Plain clear bowl shown, an option also exists for a clear bowl with water in fuel sensing port (pg7) to accept the Separ active water in fuel sensor (see later section)

Plastic bowl 10542
 Plastic bowl with thread for PG7 water sensor 10541

*** This is the 30 micron element and it is the default option, but others are available

10 micron - 01010 (paper)
 30 micron - 01030 (paper)
 60 micron - 01060s (stainless steel - washable)

A service tool for ease of lid removal is also available, part no 10661



Lightweight polymer construction filter for non-marine applications

Ideal match for the Separ hand priming pump (part 10666)

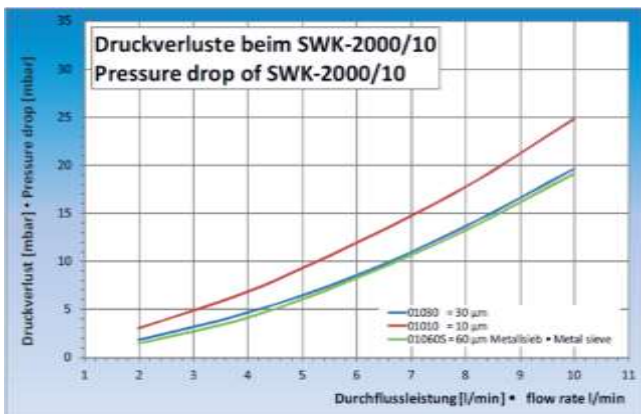
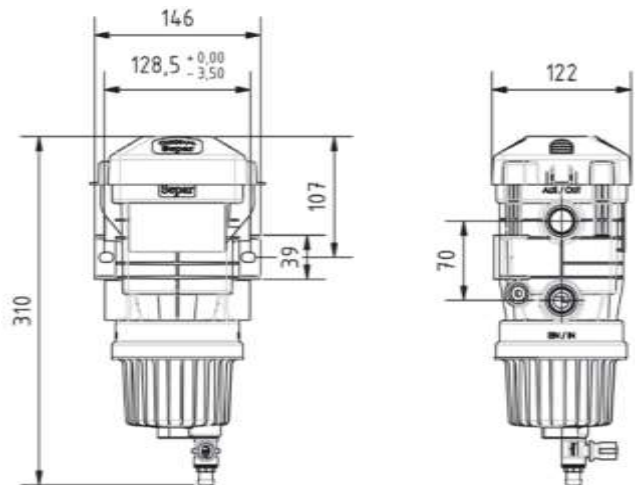
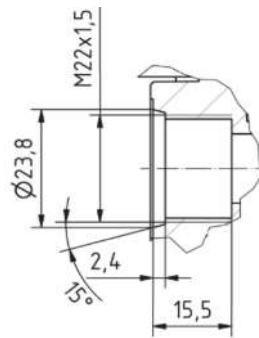
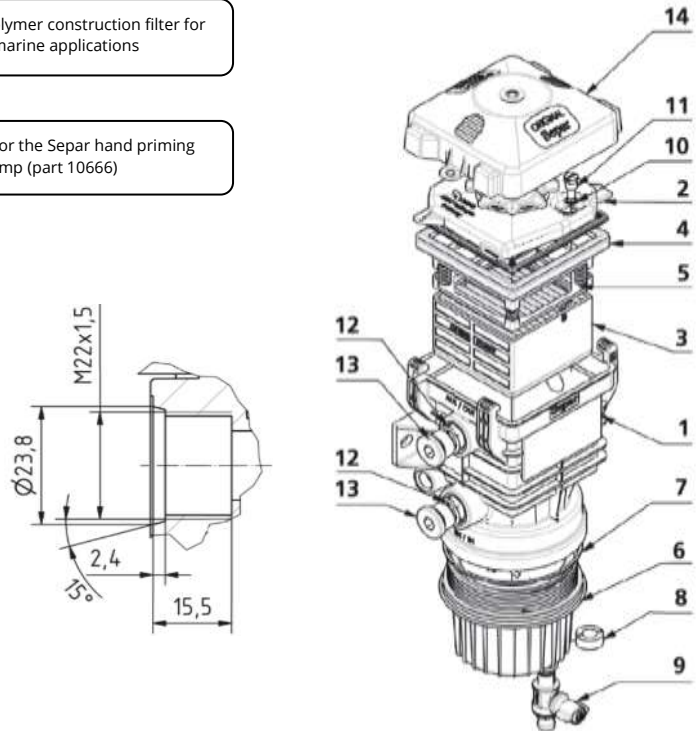

SWK2000/18 simplex

	Metric	Imperial
Max Flow	18 Litres/Min	4 Gallons/Min
Max Flow	1080 Litres/Hour	132 Gallons/Hr
Filter restriction at Max Flow 30mic element	15 mBar	0.44 in.Hg
Port Size	M26x1.5 ISO6149-1	
Water holding capacity	340ml	
Width	200mm	8 in
Height	385 mm	11.15 in
Element removal	60 mm	3 in
Total height needed	457 mm	18 in
Depth	165 mm	6.5 in
Weight	5 Kg	11 Lbs.

Item	Part No	Description
1	30428	Aluminium Filter Housing
2	30572	Aluminium Filter Lid
3	30421	Lid Gasket*
4	30298	Spring Cassette
5	01830	Filter Element***
6	30575	Bowl Retaining Ring
7	30423	Bowl Gasket*
8	8x 30448	Washer 6.4
9	4x 30452	Lid Screw
10	4x 30567	Bowl Ring Screw
11	30986	Bowl (clear)**
12	10360	Drain Valve Gasket*
13	30343	Drain Valve
14	30408	Bleed Screw
15	30558	Bleed Screw Gasket*
16	2x 30705	Port Plug
17	2x 30721	Port Plug Gasket*

* Part of gasket kit (part 30979)

** Clear bowl shown, but other options are available (below). Metal bowls have ISO10088

Plastic bowl	30986
Plastic bowl with alarm contacts	30986k
Metal bowl	30983
Metal bowl with alarm contacts	30983k
Plastic bowl, heat-shield with alarm contacts	30996

*** This is the 30 micron element and it is the default option, but others are available

- 10 micron - 01810 (paper)
- 30 micron - 01830 (paper)
- 60 micron - 01860s (stainless steel - washable)

Water in fuel sensing options are available for this filter. Also potential-free water in fuel sensing is available on this filter.

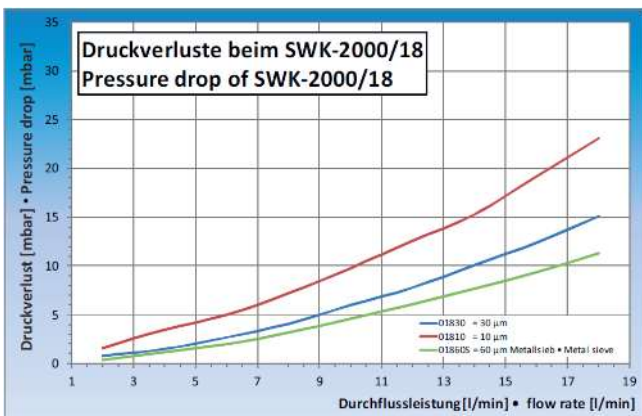
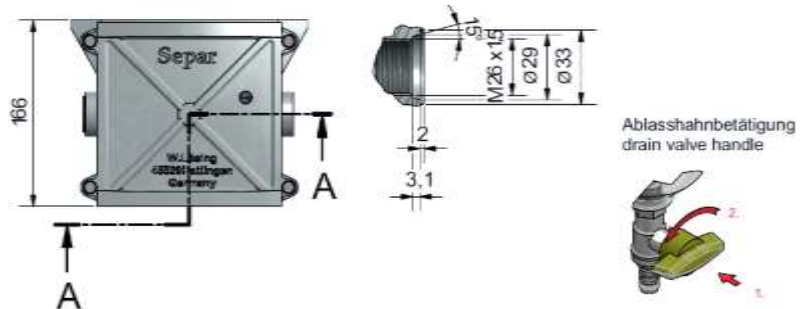
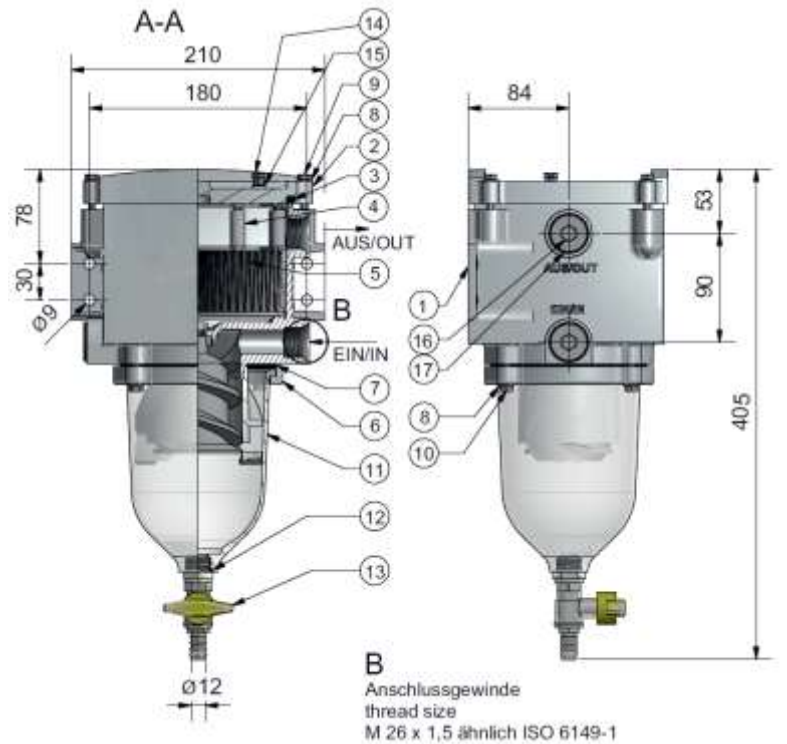

Popular part numbers
 SWK2000/18M (metal bowl)
 SWK2000/18MK (metal bowl with water in fuel sensing points)

SWK2000/18U duplex

	Metric	Imperial
Max Flow	18 Litres/Min	4 Gallons/Min
Max Flow	1080 Litres/Hour	132 Gallons/Hr
Filter restriction at Max Flow 30mic element	15 mBar	0.44 in.Hg
Port Size	22mm nut/olive (M30)****	
Water holding capacity	340ml per side	
Width	625 mm	24.5 in
Height	435 mm	18 in
Element removal	60 mm	3 in
Total height needed	457 mm	18 in
Depth	226 mm	9 in
Weight	19 Kg	42 Lbs.

Item	Part No	Description
1	2x 30428	Aluminium Filter Housing
2	2x 30572	Aluminium Filter Lid
3	2x 30421	Lid Gasket*
4	2x 30298	Spring Cassette
5	2x 01830	Filter Element***
6	2x 30575	Bowl Retaining Ring
7	2x 30423	Bowl Gasket*
8	16x 30448	Washer 6.4
9	8x 30452	Lid Screw
10	8x 30567	Bowl Ring Screw
11	2x 30986	Bowl (clear)**
12	2x 10360	Drain Valve Gasket*
13	2x 30343	Drain Valve
14	2x 30408	Bleed Screw
15	2x 30558	Bleed Screw Gasket*
16	2x 30705	Port Plug
17	2x 30721	Port Plug Gasket*
18	10217	Changeover Handle
19	2x 30339	Cutting Ring (Olive)****
20	2x 30338	Union Nut****

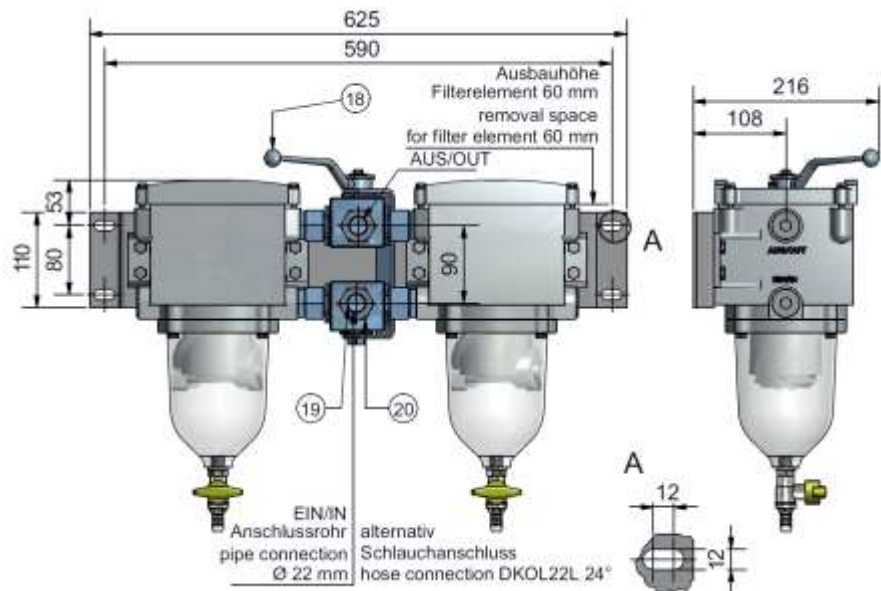

NB. Please refer to SWK2000/18 simplex for height dimension and additional parts

* Part of gasket kit (part 30979). 2 of these kits are required for a full service of this duplex filter

** Clear bowl shown. Please refer to SWK2000/18 simplex for options

*** This is the 30 micron element and it is the default option, but others are available. NB, there is one filter element in each side of this duplex assembly

- 10 micron - 01810 (paper)
- 30 micron - 01830 (paper)
- 60 micron - 01860s (stainless steel - washable)

****If the nut and olive are removed from the filter, a male M30 thread is exposed for alternative connection options

Water in fuel sensing options are available for this filter. Also potential-free water in fuel sensing is available on this filter.

The changeover handle is always over the active side of the duplex filter assembly. There is no middle position.

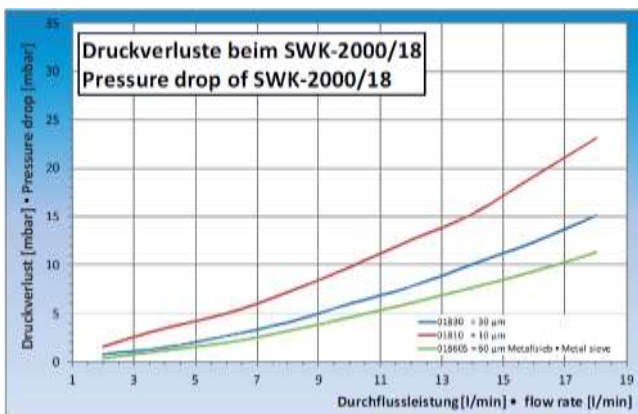

Popular part numbers
 SWK2000/18UM (metal bowl)
 SWK2000/18UMK (metal bowl with water in fuel sensing points)
 SWK2000/18UKD (clear bowl with metal heat shield and sensing points)

SWK2000/40M simplex

	Metric	Imperial
Max Flow	40 Litres/Min	9 Gallons/Min
Max Flow	2400 Litres/Hour	528 Gallons/Hr
Filter restriction at Max Flow 30mic element	32 mBar	0.95 In.Hg
Port Size	M33x2	
Water holding capacity	1.3 lit	
Width	290 mm	11.5 in
Height	480 mm	19 in
Element removal	60 mm	3 in
Total height needed	540 mm	22 in
Depth	211 mm	8.3 in
Weight	11 Kg	24 Lbs.

Item	Part No	Description
1	30434	Aluminium Filter Housing
2	30435	Aluminium Filter Lid
3	30440	Lid Gasket*
4	30299	Spring Cassette
5	04030	Filter Element***
6	30446	Bowl Retaining Ring
7	30442	Bowl Gasket*
8	8x 30021	Washer 8.4
9	4x 30404	Lid Screw
10	4x 30567	Bowl Ring Screw
11	30457	Bowl (metal)**
12	30448	Drain Valve Gasket*
13	30456	Drain Valve
14	30408	Bleed Screw
15	30558	Bleed Screw Gasket*
16	2x 30445	Port Plug
17	2x 30544	Port Plug Gasket*

* Part of gasket kit (part 30980)

** Metal bowl shown, all models in this range are ISO10088 compliant.

Please note, there are no clear bowls for this filter

Metal bowl 30457
 Metal bowl with alarm contacts 30457k

*** This is the 30 micron element and it is the default option, but others are available

10 micron - 04010 (paper)
 30 micron - 04030 (paper)
 60 micron - 04060s (stainless steel - washable)

Water in fuel sensing options are available for this filter. Also potential-free water in fuel sensing is available on this filter.

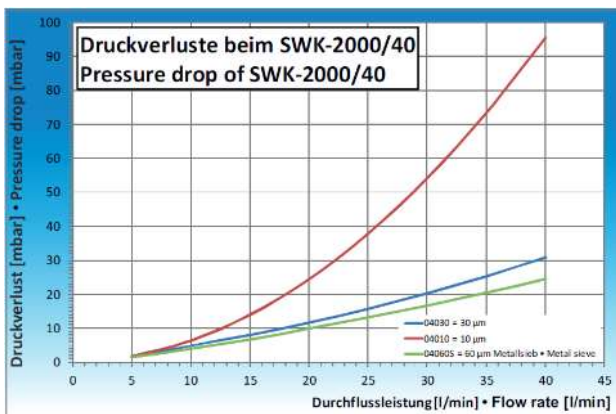
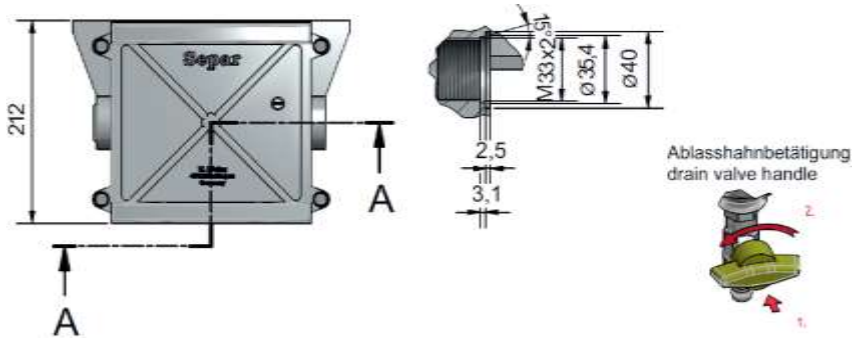
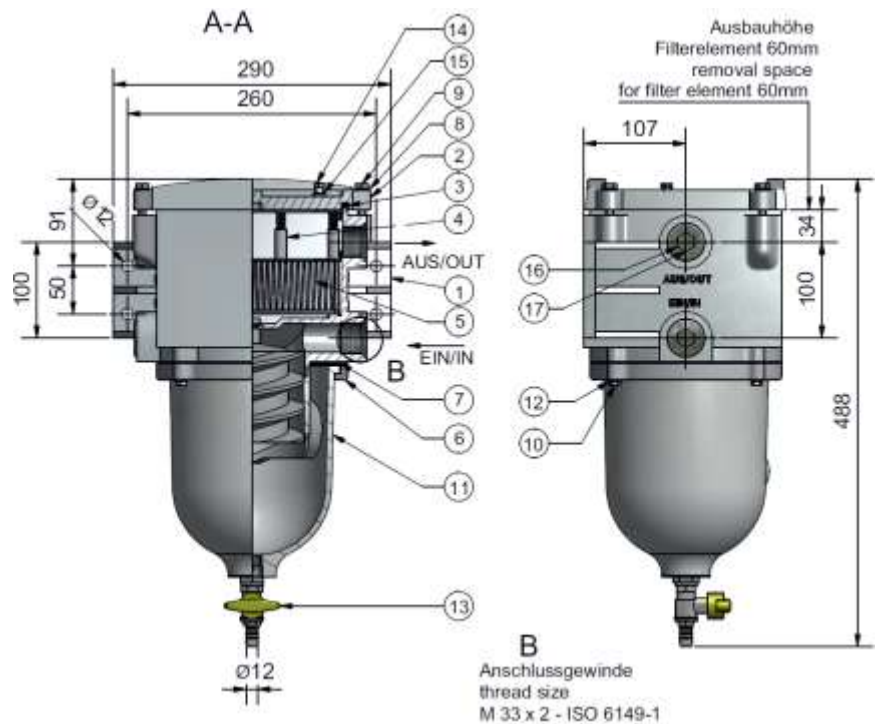

Popular part numbers
 SWK2000/40M (metal bowl)
 SWK2000/40MK (metal bowl with water in fuel sensing points)

SWK2000/40U duplex

	Metric	Imperial
Max Flow	40 Litres/Min	9 Gallons/Min
Max Flow	2400 Litres/Hour	528 Gallons/Hr
Filter restriction at Max Flow 30mic element	32 mBar	0.95 In.Hg
Port Size	35mm nut/olive (M45)****	
Water holding capacity	1.3 lit per side	
Width	795 mm	31 in
Height	530 mm	20.9 in
Element removal	60 mm	3 in
Total height needed	559 mm	31.3 in
Depth	280 mm	11 in
Weight	37 Kg	81 Lbs.

Item	Part No	Description
1	10048	Left Hand Alu. Filter Housing
1a	10049	Right Hand Alu. Filter Housing
2	2x 30435	Aluminium Filter Lid
3	2x 30440	Lid Gasket*
4	2x 30299	Spring Cassette
5	2x 04030	Filter Element***
6	2x 30446	Bowl Retaining Ring
7	2x 30442	Bowl Gasket*
8	16x 30021	Washer 8.4
9	8x 30404	Lid Screw
10	8x 30567	Bowl Ring Screw
11	2x 30457	Bowl (metal)**
12	2x 30448	Drain Valve Gasket*
13	2x 30456	Drain Valve
14	2x 30408	Bleed Screw
15	2x 30558	Bleed Screw Gasket*
16	4x 30445	Port Plug
17	4x 30544	Port Plug Gasket*
18	10218	Changeover Handle
19	2x 30341	Cutting Ring (Olive)****
20	2x 30340	Union Nut *****

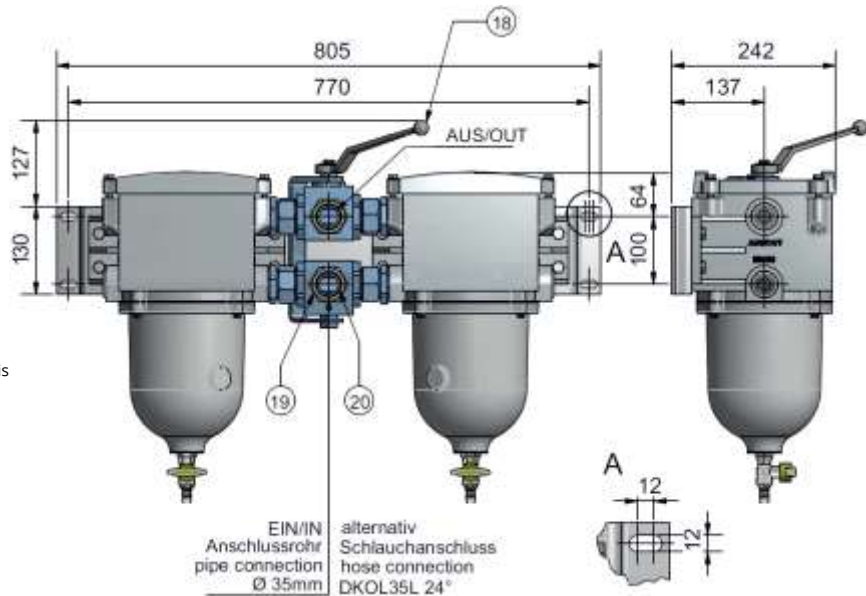

NB. Please refer to SWK2000/40 simplex for height dimension and additional parts

* Part of gasket kit (part 30980). 2 of these kits are required for a full service of this duplex filter

** Metal bowl shown. Please refer to SWK2000/40M simplex for options

*** This is the 30 micron element and it is the default option, but others are available. NB, there is one filter element in each side of this duplex assembly

- 10 micron - 04010 (paper)
- 30 micron - 04030 (paper)
- 60 micron - 04060s (stainless steel - washable)

****If the nut and olive are removed from the filter, a male M45 thread is exposed for alternative connection options

Water in fuel sensing options are available for this filter. Also potential-free water in fuel sensing is available on this filter.

The changeover handle is always over the active side of the duplex filter assembly. There is no middle position.

Note - the left and right hand filter housings are different part numbers to the simplex version

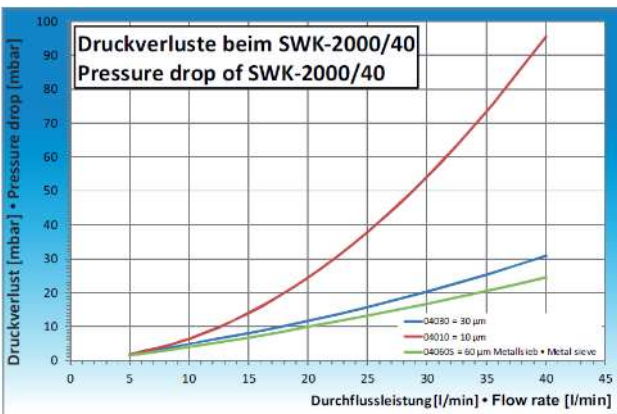

Popular part numbers
 SWK2000/40UM (metal bowl)
 SWK2000/40UMK (metal bowl with water in fuel sensing points)

SWK2000/40/2 double simplex

	Metric	Imperial
Max Flow	80 Litres/Min	17.5 Gallons/Min
Max Flow	4800 Litres/Hour	1056 Gallons/Hr
Filter restriction at Max Flow 30mic element	32 mBar	0.95 In.Hg
Port Size	42mm nut/olive	
Water holding capacity	2.6 lit	
Width	870 mm	34 in
Height	480 mm	19 in
Element removal	60 mm	3 in
Total height needed	540 mm	22 in
Depth	211 mm	8.3 in
Weight	31 Kg	69 Lbs.

Item	Part No	Description
1	10048	Left Hand Alu. Filter Housing
1a	10049	Right Hand Alu. Filter Housing
2	2x 30435	Aluminium Filter Lid
3	2x 30440	Lid Gasket*
4	2x 30299	Spring Cassette
5	2x 04030	Filter Element***
6	2x 30446	Bowl Retaining Ring
7	2x 30442	Bowl Gasket*
8	16x 30021	Washer 8.4
9	8x 30404	Lid Screw
10	8x 30567	Bowl Ring Screw
11	2x 30457	Bowl (metal)**
12	2x 30448	Drain Valve Gasket*
13	2x 30456	Drain Valve
14	2x 30408	Bleed Screw
15	2x 30558	Bleed Screw Gasket*
16	4x 30445	Port Plug
17	4x 30544	Port Plug Gasket*
18	10218	Changeover Handle
19	2x 30341	Cutting Ring (Olive)****
20	2x 30340	Union Nut *****

NB. Please refer to SWK2000/40 simplex for height dimension and additional parts

- * Part of gasket kit (part 30980). 2 of these kits are required
- ** Metal bowl shown. Please refer to SWK2000/40M simplex for options
- *** This is the 30 micron element and it is the default option, but others are available
 - 10 micron - 04010 (paper)
 - 30 micron - 04030 (paper)
 - 60 micron - 04060s (stainless steel - washable)

NB, there are two filter elements inside this unit

****If the nut and olive are removed from the filter, a male M45 thread is exposed for alternative connection options

Water in fuel sensing options are available for this filter. Also potential-free water in fuel sensing is available on this filter.

Note - the left and right hand filter housings are different part numbers to the simplex version

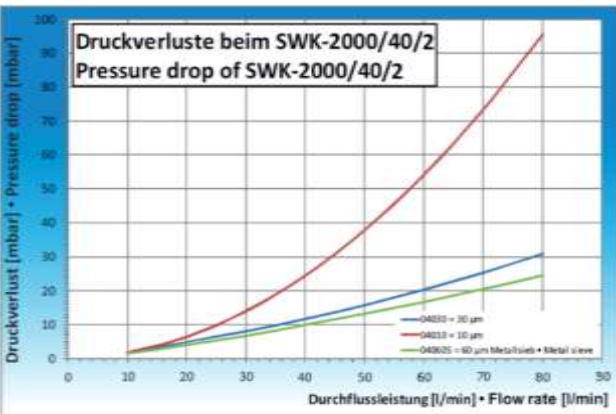
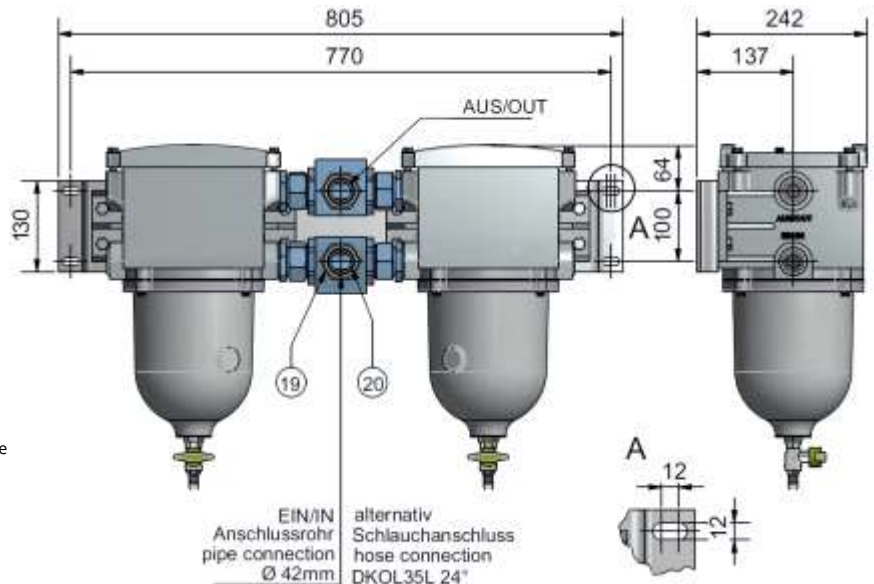

Popular part numbers
 SWK2000/40/2M (metal bowl)
 SWK2000/40/2MK (metal bowl with water in fuel sensing points)

SWK2000/130 simplex

	Metric	Imperial
Max Flow	130 Litres/Min	28.5 Gallons/Min
Max Flow	7800 Litres/Hour	1733 Gallons/Hr
Filter restriction at Max Flow 30mic element	32 mBar	0.95 In.Hg
Port Size	2" female thread (G2")	
Water holding capacity	7 lit	
Width	370 mm	14.5 in
Height	810mm	32 in
Element removal	60 mm	3 in
Total height needed	870 mm	34 in
Depth	370 mm	14.5 in
Weight	50 Kg	110 Lbs

Item	Part No	Description
1	10050	Aluminium Filter lid
2	30387	Lid Gasket*
3	10136	Bottom Gasket*
4	10135	Aluminium Filter Bottom
5	4x 01830	Filter Element***
6	4x 30298	Spring Cassette
7	16x 10073	M8 dome nut
8	22x 30021	Washer 8.4
9	6x 10137	M8 Hex Nut
10	2x 20034	USIT Ring
11	10244	Solid Port Plug
12	10245	Port Plug with centre thread
13	10074	Fuel Bleed Valve
14	30456	Water Drain Valve
15	30366-1	Air Bleed Valve
16	10139	Air Bleed Valve Gasket*
17	20317	Vacuum gauge

* Part of gasket kit (part 30993)

All models in this range are ISO10088 compliant. Please note, there are no clear bowls for this filter

** This is the 30 micron element and it is the default option, but others are available. 4 elements used per filter body.

10 micron – 4x 01810 (paper)
 30 micron – 4x 01830 (paper)
 60 micron – 4x 01860s (stainless steel – washable)

Water in fuel sensing options are available for this filter. Also potential-free water in fuel sensing is available on this filter.

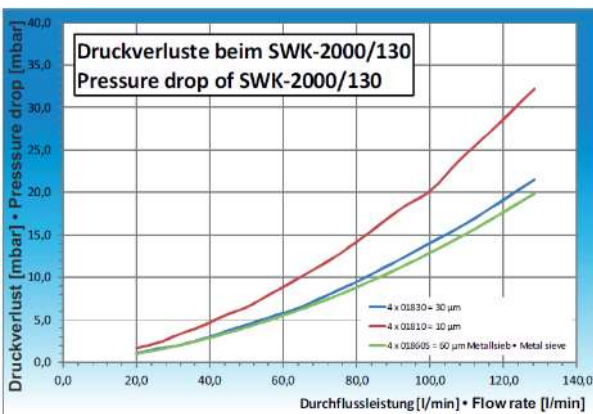
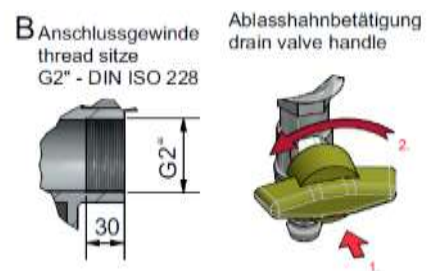
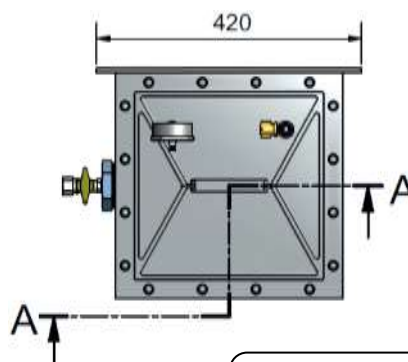
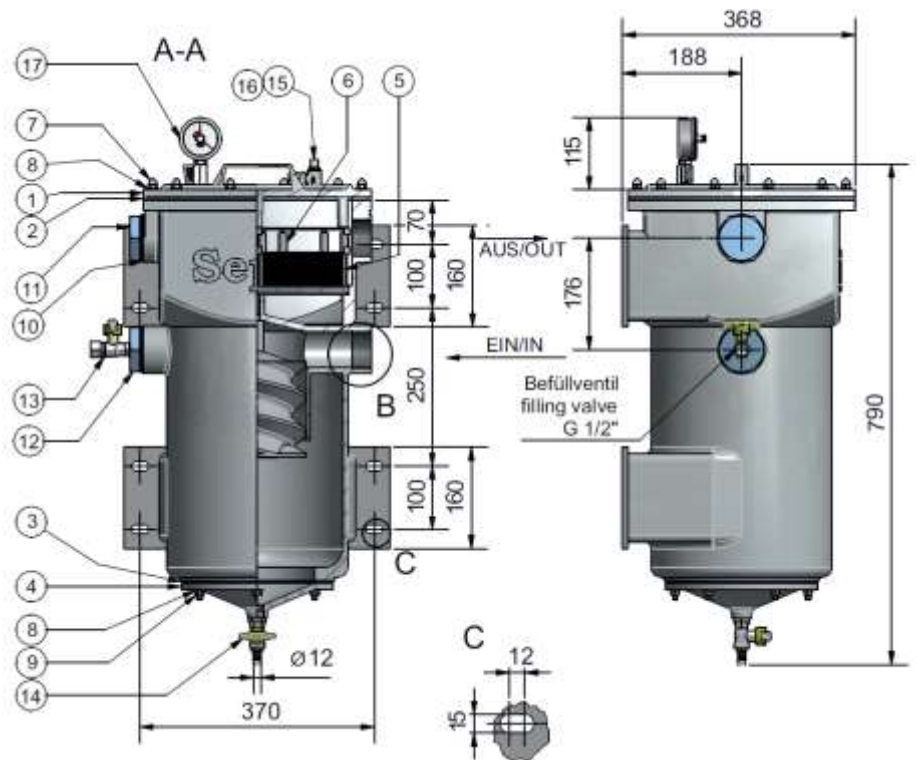

Popular part numbers
 SWK2000/130M (metal bowl)
 SWK2000/130MK (metal bowl with water in fuel sensing points)

SWK2000/130U duplex

	Metric	Imperial
Max Flow	130 Litres/Min	28.5 Gallons/Min
Max Flow	15600 Litres/Hour	3432 Gallons/Hr
Filter restriction at Max Flow 30mic element	32 mBar	0.95 In.Hg
Port Size	3" nut/olive	
Water holding capacity	7 lit per side	
Width	1095 mm	45 in
Height	813 mm	32 in
Element removal	60 mm	3 in
Total height needed	889 mm	35 in
Depth	370 mm	14.6 in
Weight	115 Kg	253 Lbs

Item	Part No	Description
1	2x 10050	Aluminium Filter lid
2	2x 30387	Lid Gasket*
3	2x 10136	Bottom Gasket*
4	2x 10135	Aluminium Filter Bottom
5	8x 01830	Filter Element**
6	8x 30298	Spring Cassette
7	32x 10073	M8 dome nut
8	44x 30021	Washer 8.4
9	12x 10137	M8 Hex Nut
10	2x 20034	USIT Ring
11	2x 10244	Solid Port Plug
12	2x 10245	Port Plug with centre thread
13	2x 10074	Fuel Bleed Valve
14	2x 30456	Water Drain Valve
15	2x 30366-1	Air Bleed Valve
16	2x 10139	Air Bleed Valve Gasket*
17	2x 20317	Vacuum gauge
18	TBC	Port Plug Gasket
19	TBC	M18 Port Plug
20	TBC	Changeover Handle

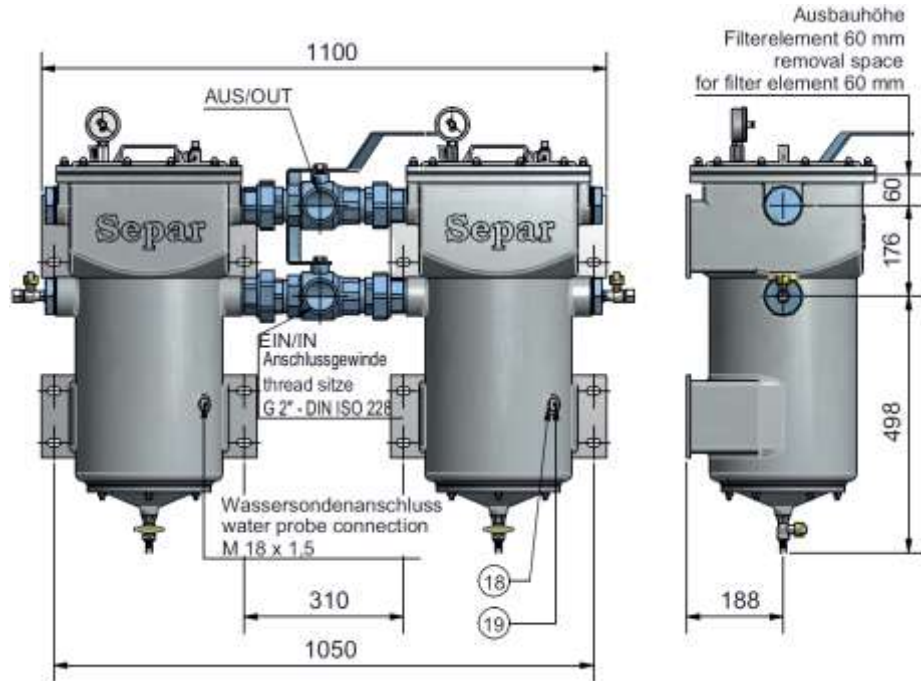

NB. Please refer to SWK2000/130 simplex for height dimension and additional parts

* Part of gasket kit (part 2x 30993)

All models in this range are ISO10088 compliant. Please note, there are no clear bowls for this filter

** This is the 30 micron element and it is the default option, but others are available. 8 elements are used in this filter (4 per filter body).

- 10 micron – 8x 01810 (paper)
- 30 micron – 8x 01830 (paper)
- 60 micron – 8x 01860s (stainless steel – washable)

Water in fuel sensing options are available for this filter. Also potential-free water in fuel sensing is available on this filter.

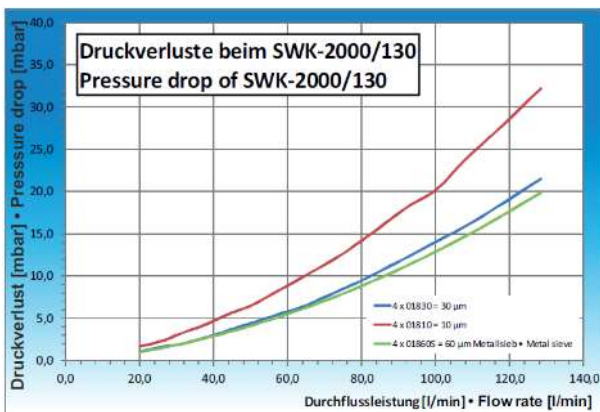

Popular part numbers
 SWK2000/130/UM (metal bowl)
 SWK2000/130/UMK (metal bowl with water in fuel sensing points)

SWK2000/130/2 double simplex

	Metric	Imperial
Max Flow	260 Litres/Min	57 Gallons/Min
Max Flow	15600 Litres/Hour	3432 Gallons/Hr
Filter restriction at Max Flow 30mic element	32 mBar	0.95 In.Hg
Port Size	3" female thread (G3")	
Water holding capacity	14 lit	
Width	1095 mm	45 in
Height	813 mm	32 in
Element removal	60 mm	3 in
Total height needed	889 mm	35 in
Depth	370 mm	14.6 in
Weight	115 Kg	253 Lbs

Item	Part No	Description
1	2x 10050	Aluminium Filter lid
2	2x 30387	Lid Gasket*
3	2x 10136	Bottom Gasket*
4	2x 10135	Aluminium Filter Bottom
5	8x 01830	Filter Element**
6	8x 30298	Spring Cassette
7	32x 10073	M8 dome nut
8	44x 30021	Washer 8.4
9	12x 10137	M8 Hex Nut
10	2x 20034	USIT Ring
11	2x 10244	Solid Port Plug
12	2x 10245	Port Plug with centre thread
13	2x 10074	Fuel Bleed Valve
14	2x 30456	Water Drain Valve
15	2x 30366-1	Air Bleed Valve
16	2x 10139	Air Bleed Valve Gasket*
17	2x 20317	Vacuum gauge
18	TBC	Port Plug Gasket
19	TBC	M18 Port Plug

NB. Please refer to SWK2000/130 simplex for height dimension and additional parts

* Part of gasket kit (part 2x 30993)

All models in this range are ISO10088 compliant. Please note, there are no clear bowls for this filter

** This is the 30 micron element and it is the default option, but others are available. 8 elements are used in this filter (4 per filter body).

- 10 micron – 8x 01810 (paper)
- 30 micron – 8x 01830 (paper)
- 60 micron – 8x 01860s (stainless steel – washable)

Water in fuel sensing options are available for this filter. Also potential-free water in fuel sensing is available on this filter.

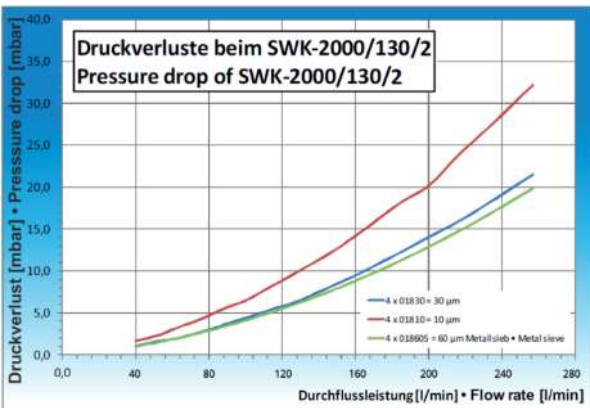
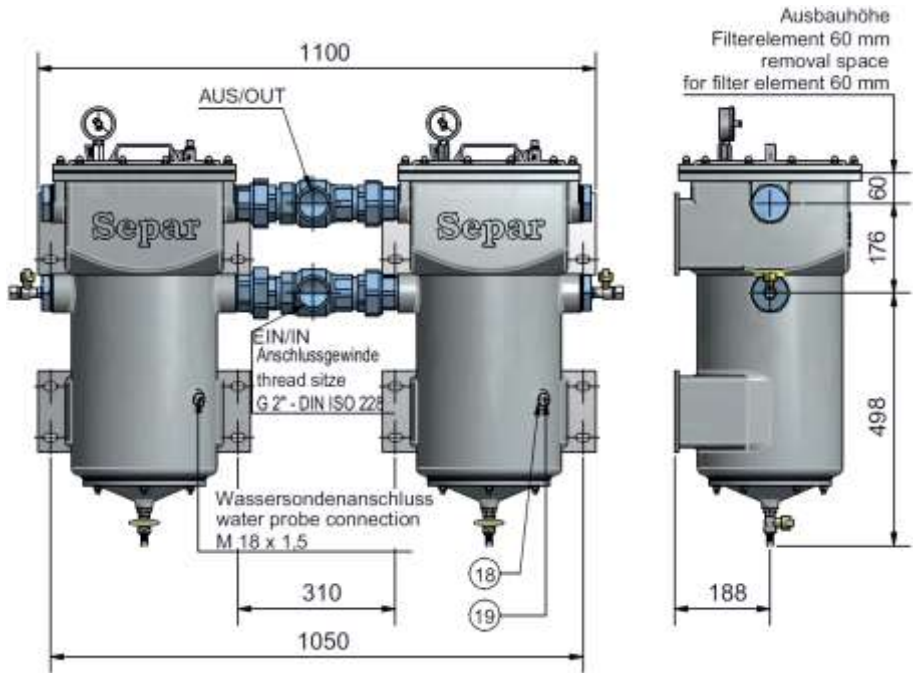

Popular part numbers
 SWK2000/130/2M (metal bowl)
 SWK2000/130/2MK (metal bowl with water in fuel sensing points)

SWK2000 Range Steel Filters (SOLAS)

These units are specifically designed to meet the SOLAS regulations for fireproofing of fuel filter components on large ships.

As a special order item, we can offer steel versions of the following SWK2000 filters.

Simplex	Duplex
SWK2000/18-ST	SWK2000/18U-ST
SWK2000/40-ST	SWK2000/40U-ST

Please refer to the aluminium construction versions on previous pages for the generic product data.

Please contact Separ UK for more details.



SWK2000/18-ST

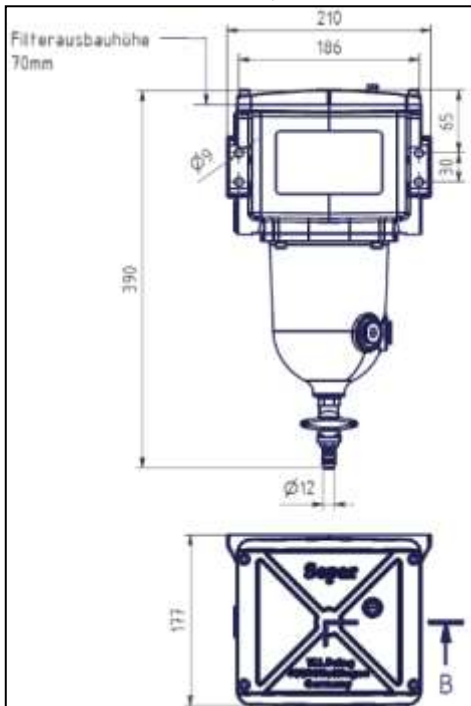

SWK2000/18U-ST

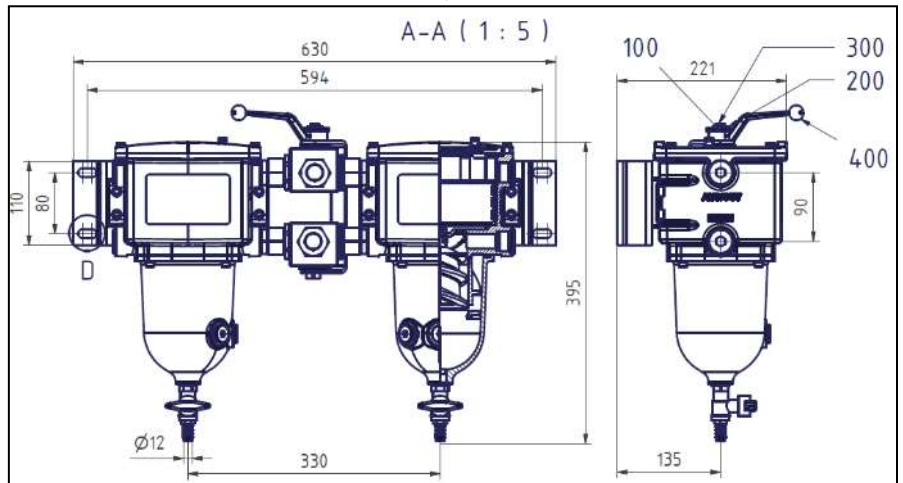

SWK2000/40U-ST

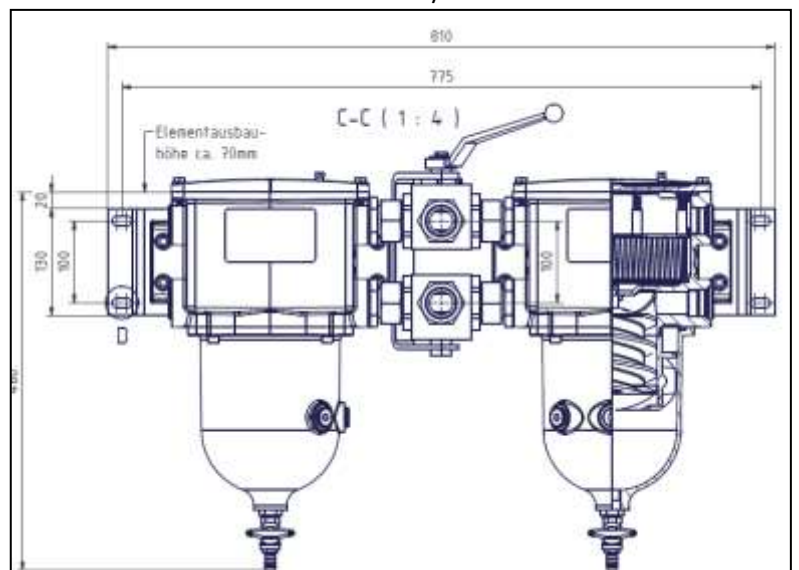

Please note, the data provided on this range is for illustration only. Please contact us for more information.

Active/Passive Water in Fuel Sensors

Traditional lamp signalling water in fuel sensor (for SWK range with suffix "K")

Part number	Description
30090	12v water contamination sensor for SWK filter range
30091	24v water contamination sensor for SWK filter range
30400	Optional audible alarm system (12v or 24v)

24v unit will draw 50ma

12v unit will draw 100ma

To attach to any Separ SWK2000 filter with the option letter K in the part number e.g. SWK2000/10MK

The bulb can be tested by shorting out the two grey water contacts – however this must not be done if fuel is present.

We always recommend testing the bulb with the connectors separate to the fuel filter.

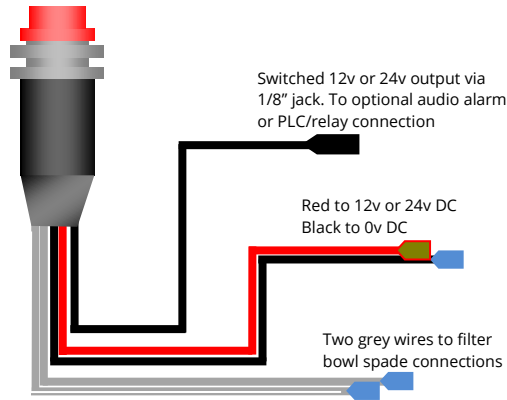

When water is detected the lamp will illuminate and, should the optional buzzer be attached, it will sound. Once the water has been removed from the sensor contact points, the signal will disappear. The 1/8" output jack has a permanent supply voltage (either 12 or 24v) and a switched 0v wire. This can be used to drive a relay or similar if required.

Active Water in Fuel Sensor (for LKF, Evo-10 and SWK range with Pg7 thread)

Supply Voltage	12 VDC – 24 VDC	Operating Temperature Range	-40°C to 85°C
Supply Voltage (max)	34 VDC	Storage Temperature Range	-40°C to 85°C
Output Resistance at logic 0 (no water sensed)	100 Ohm approx.	Detection threshold	42,000 Ohm approx.
Output Resistance at logic 1 (water sensed)	2,300 Ohm approx.	Power consumption	15mA
Thread	PG7 (1/2"x20UNF)	Body colour	Black

10273	Sensor with metal case, flying leads
10381	Sensor with AMP plug (male), standard
20891	Sensor with AMP plug (male), alternative wiring (see below)
10834	Mating AMP connector only (female)
10343	102dB 24v audio alarm

Connection	10273 Flying lead wire colours	10381 AMP Plug	20891 AMP plug
U+	Blue	Pin 2	Pin 1
U-	Black	Pin 1	Pin 2
Out Minus	White	Pin 3	Pin 3
Out Plus	Brown	Pin 4	Pin 4

All types – function chart

Connection	No water detected	Water detected	Sensor disturbance
Out Minus	Supply voltage	0v	Supply voltage/0v at 4hz
Out Plus	0v	Supply voltage	Supply voltage/0v at 4hz

The sensor has a 1 second debounce to avoid false triggering.

The sensor will stay in its triggered state even after water is no longer present. To reset, cycle the power.

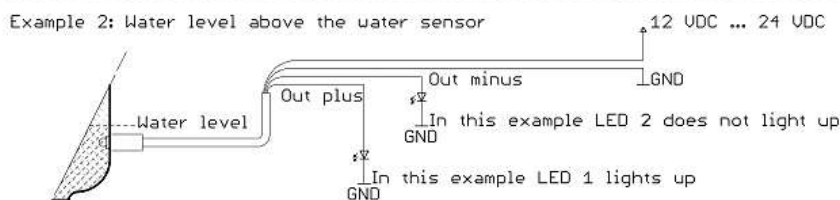
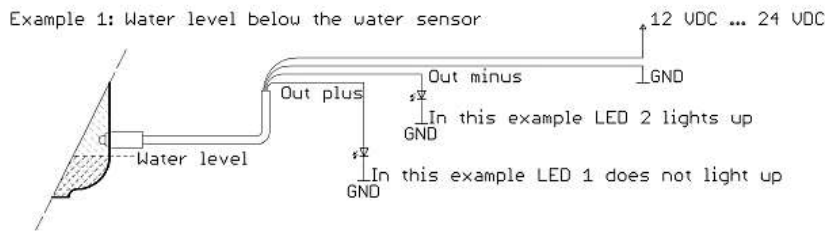
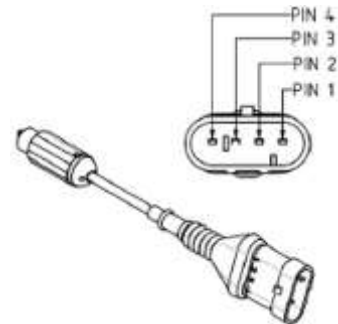

Separ UK (ISO9001:2015)

3 Kingley Park, Station Road, Kings Langley, Herts, WD4 8GW
sales@separ.co.uk www.separ.co.uk +44(0)1923 276007

SWK2000, LKF and Evo10 filter ranges catalogue rev1903



Hand Priming Pump

Model number: 10666

- No differential pressure drop
- Compact size
- High slow rate and lift capacity
- Placed in suction line between filter and pump
- Diesel and biodiesel (B100)
- Can be mounted horizontally or vertically

The unique design of the Separ priming pump allows for an unrestricted flow of fuel through the pump in normal operation, then when needed, the main body is simply rotated to bring the priming pump into the fuel line.

This high capacity pump can therefore be left in-line and brought into and out of use as and when needed, providing the simplest way to prime your Separ fuel filter and fuel system.

The pump should be positioned after your Separ fuel filter/water separator in the suction line before the electronic lift pump. The mounting position is not critical, as long as its accessible the unit can be mounted any way up.

Technical details

Part number	10666
Differential pressure drop	0 mbar
Stroke volume	25ml
Suction head (max)	5m
Pressure outlet (max)	7bar
Operating temperature	-40 °C to + 120°C
Internal diameter	12mm (½")
Port threads	M22x1.5



Pull plunger handle to pump

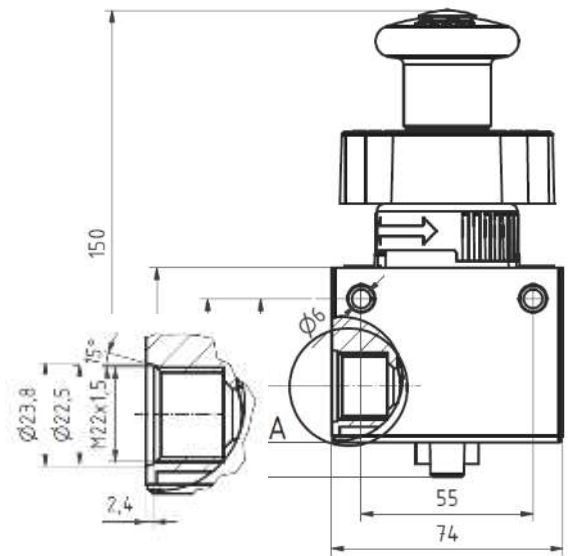
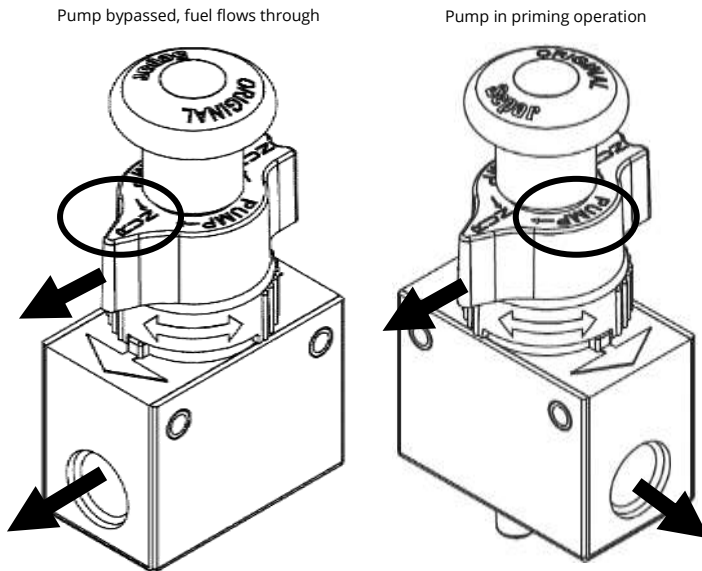

Vacuum gauge

Model number: 30650

Adjustable vacuum / pressure gauge

- -600mbar to +600mbar
- Glycol filled
- Tell-tale adjustable needle
- ¼" BSP-P male thread
- 2" dial
- No differential pressure drop

The Separ adjustable vacuum gauge is a simple and effective way to tell how full your filter is.

Suitable for the SWK2000 range (with special filter lid), or all ranges if placed in the pipe work between your filter and your lift pump, this gauge can be inserted in to a special filter lid (ask for details) which has a ¼" BSP hole tapped in it; by fitting it to the filter lid the gauge is monitoring the clean side of the filter.

This gauge can alternatively be fitted in the output pipe work leading from the filter towards the fuel lift pump.

There is a small cap on the top of the gauge. When supplied a certain amount of air will be present inside the gauge; this should be expelled by the temporary removal of this cap. With the air bubble gone, the normally damped operation of this gauge can commence.

The ideal setup is to insert a clean filter element into your unit, switch the pump on and record red needle reading using the adjustable black needle. That is your start point against which you can monitor the filter's performance. Over time the filter will pull out contamination from the fuel, causing more of a restriction, which will be evident by an increase in the vacuum reading on the clean side of the filter - this will be recorded by the red needle.

Compare the current position of the red needle to the previously set black needle position (the clean restriction). When these two differ by 275mbar (4psi); your filter requires servicing.



Example of a gauge inserted in a filter lid

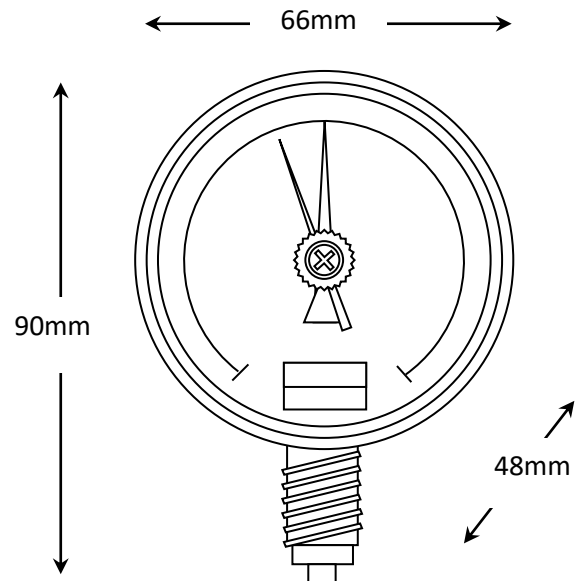

Adjustable vacuum switch

Vacuum switch SPST N.O for service alarms

In order to trigger an electrical signal when a filter has reached its service level, the use of a vacuum switch is important. As the Separ SWK2000, LKF or Evo-10 are vacuum side filters, the "C-VAC-SWITCH-ADJ" is the ideal unit.

Specification

Adjusting range	200 - 900 mbar
Thread	¼" BSP taper
"F" Contact holder	Nylon 6.6
Protection cap	black NBR
Membrane	Viton
Body	Tropicalized steel
Electric contact	Silver plated copper at 3 µ
Maximum voltage	48 V
Current	0.5A (resistive), 0.2A (inductive)
Working temperature	-5° +60 °C
Protection without cap	IP 00
Protection with cap	IP 54
Mechanical life	10,000,000 cycles
Tightening torque	5 N max.
Contacts	SPST Normally open; closed when set point vacuum is reached

Our adjustable membrane vacuum switches have been designed to check and signal the vacuum status in diesel filtration systems. The sensitive Viton membrane detects changes in vacuum, and when it reaches the user-set level, closes the normally open electrical contacts. This allows the user to utilise the switch to trigger a PLC, lamp, buzzer or similar device to indicate a service is required.

Switches can be supplied separately (c/w protective cap), with fittings to suit the Separ SWK2000 range, or with in-line port fittings.



C-VAC-SWITCH-ADJ

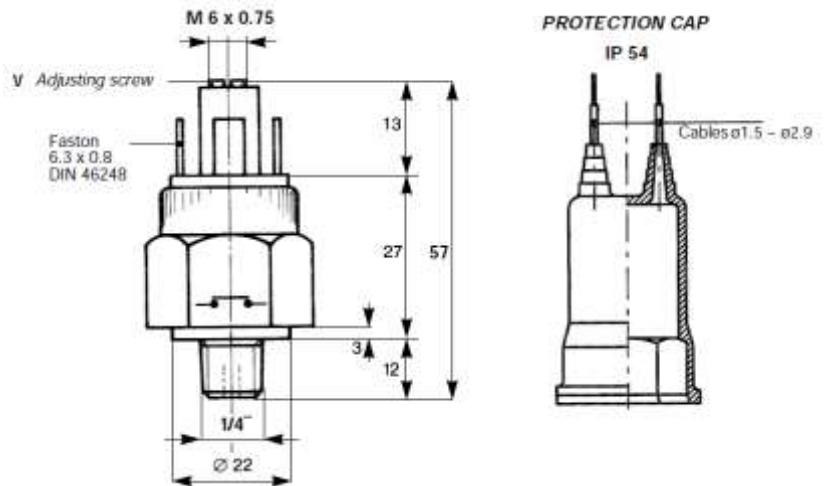

C-VAC-SWITCH-ADJ + fitting for SWK2000 filter



C-VAC-SWITCH-ADJ + fitting with in-line port



Ordering procedure

Ordering from Separ UK is easy. Simply make a note of the products you require and either:

- Call +44(0)1923 276007
- Email sales@separ.co.uk
- Send a message to us via our web site's 'contact us' section (www.separ.co.uk)
- Fax +44(0) 1923 267463
- Post orders to Separ UK, 3 Kingley Park, Station Road, Kings Langley, Herts, WD4 8GW

If you need help, please contact us.

We are very happy to help select products for you, offer technical advice and provide further product data if required.

Payments

We accept payment by

- Bank transfer (BACS, CHAPS, Internet banking and bank transfers, please contact us for our bank details).
- Debit cards
- Credit Cards
- Cheques made payable to "Separ UK"