

Max. Flow Rate: 285 GPH (1,080 LPH)

- Separ 2000 series water separators fuel filters are a simple solution to many different fuel related problems.
- Five separate stages of filtration ensure 99.9% water separation (Certified TUV Report using SAE J1839) at maximum flow.
- Low restriction reduces wear on fuel pumps and ensures full RPMs.
- Backflushable (cleanable) element reduces down time and costly element changes.
- Marine version with U.S. Coast Guard-accepted metal heat deflector.

INDUSTRIAL



MARINE



Shown: Industrial (left to right) 2000/18, 2000/18U
Marine (left to right) 2000/18D-G, 2000/18UD-G

Inlet / Outlet Connections

Single Unit: 1 1/16-12 Straight o-ring SAE
Duplex Unit: Shipped with #12 Male JIC Flare
(other adapters available)
Inlet and Outlet Pipe connection 22mm.

Ordering Specifications

SWK-2000/18 U M MK K KD D A - G

Duplex _____
Metal bowl _____
Metal bowl w/ contacts _____
Clear bowl w/ water contacts _____
Clear bowl w/ metal heat deflector
and water contacts _____
Clear bowl w/ metal heat deflector _____
Automatic switchable duplex _____
(See page 18 for details)
Gauge _____

We reserve the right to alter the specification without prior notice.

Pressure Drop

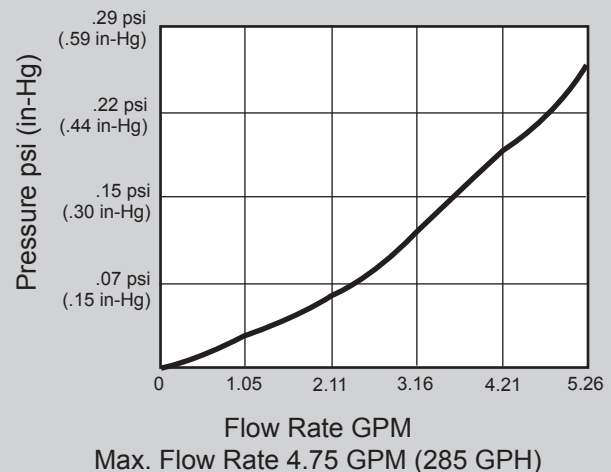

INDUSTRIAL

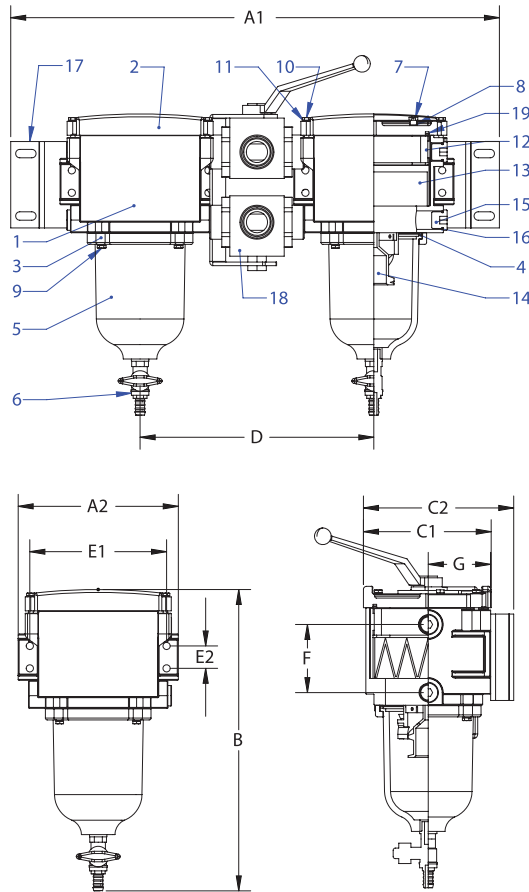

MARINE

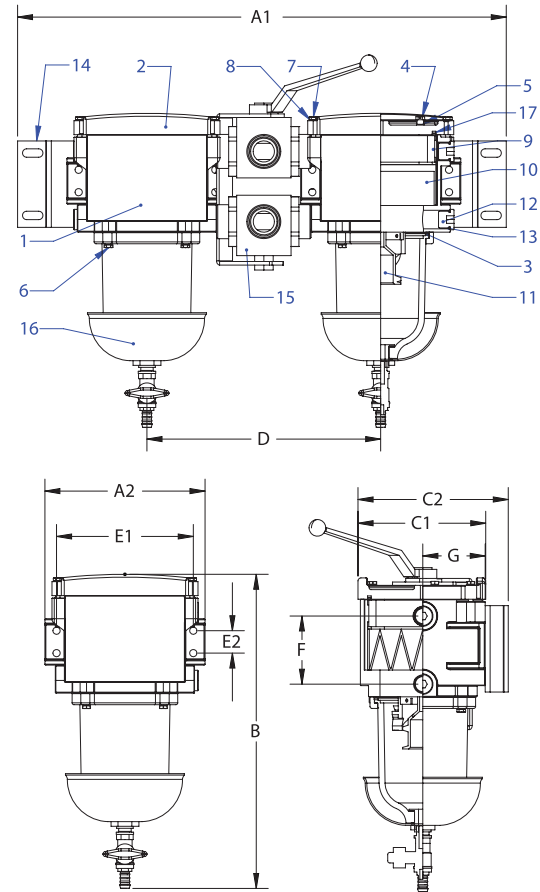

Item	Part #	Description	Dimension		Item	Part #	Description	Dimension		
1	30428	Housing	A1	25.5"	1	30428	Housing	A1	25.5"	
2	30572	Lid		(446.4mm)	2	30572	Lid		(446.4mm)	
3	30575	Retaining Ring	A2	8.34"	3	30423	Bowl Gasket	A2	8.34"	
4	30423	Bowl Gasket		(211.8mm)	4	30408	Bleed Screw		(211.8mm)	
5	30986	Bowl	B	15.7"	5	30558	Bleed Screw Gasket	B	15.7"	
6	30343	Drain Valve		(398.8mm)	6	30567	Bowl Screw		(398.8mm)	
7	30408	Bleed Screw	C1	6.6"	7	30452	Lid Screw	C1	6.6"	
8	30558	Bleed Screw Gasket		(168.3mm)	8	30448	Washer	C2	7.83"	
9	30567	Bowl Screw	C2	7.83"	9	30298	Spring Frame		(198.9mm)	
10	30452	Lid Screw	D	12.2"	10		Filter Element	D	12.2"	
11	30448	Washer		(309.2mm)		01810	10 Micron		(309.2mm)	
12	30298	Spring Frame	E1	7.12"		01830	30 Micron (standard)	E1	7.12"	
13		Filter Element	E2	1.17"		01860S	60 Micron (stainless steel)	E2	1.17"	
	01810	10 Micron		(29.6mm)	11	30429	Centrifuge		(29.6mm)	
	01830	30 Micron (standard)	F	3.55"	12	30705	Plug	F	3.55"	
	01860S	60 Micron (stainless steel)		(90.1mm)	13	30721	Plug O-Ring		(90.1mm)	
14	30429	Centrifuge	G	3.25"	14	30466	Mounting Bracket	G	3.25"	
15	30705	Plug		(82.6mm)	15	30465	Reversing Valve Assembly		(82.6mm)	
16	30721	Plug O-Ring	Model		Weight		Model		Weight	
17	30466	Mounting Bracket	SWK-2000/18	10.5 lbs			SWK-2000/18D	11 lbs		
18	30465	Reversing Valve Assembly	SWK-2000/18U	34.5 lbs			SWK-2000/18UD	35.5 lbs		
19	30421	Lid Gasket		(4.76 kg)				(16.10kg)		
					16		Bowl Assembly			
						30990W	Single Unit (white)		(4.99 kg)	
						30990	Duplex Unit (grey)			
					17	30421	Lid Gasket			