

Electric RetroFit Kit for Bennett Trim Tabs Installation Instructions

Lenco Marine's RetroFit Kit is designed as a direct replacement for the Bennett hydraulic power unit (HPU) on systems using Bennett's 4-ring standard trim tab actuators.

Note: Bennett Joystick Control cannot be retrofitted to the Lenco actuators, but will retrofit both Bennett rocker switches. You may also want to consider replacing your Trim Tab switch at this time. Please visit our website (www.lencomarine.com) for a list of available Lenco switch kits.

Make sure the power is removed from the Bennett Trim Tab System before installation.

Disconnect Bennett System

1) Disconnect the Bennett hydraulic pump unit (HPU) from the Bennett wiring harness and drain as much of the hydraulic fluid as possible into a container for proper disposal later. Remember that automatic transmission fluid (ATF) is to be disposed of only at an approved collection site in your area; do not discard in the regular trash. Discard hydraulic pump unit (HPU). **Leave Bennett wiring harness in place.**

2) Remove and discard the Bennett trim tab cylinders from the boat transom and remove the hydraulic line at the connection. It helps to have several rags handy to soak up the oil. Remove and discard old hydraulic lines.

Disconnect the Bennett cylinder from the trim tab plane by tapping out the small black pin at the base of the cylinder where it attaches to the plane. You will first have to remove one screw from the lower mounting bracket as this holds the pin in place. **Do not remove the lower mounting bracket, as you will need it later.**

Now you are ready to begin the Lenco Installation

1) Insert the actuator cable through the appropriate hole in the upper mounting bracket (supplied with the kit) until it reaches the actuator. Insert the actuator cable thru the gland seal until it reaches the upper mounting bracket.

Note: For appropriate orientation of upper mounting bracket and gland seal, (see Fig 1).

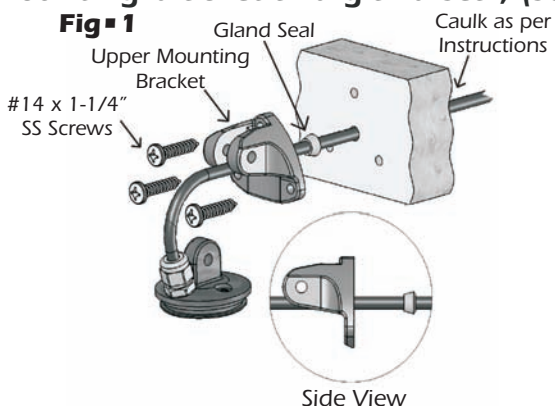

You will need to clean the mounting surfaces on the transom with a cleaning solvent such as mineral spirits or alcohol to remove all oils and dirt before final mounting. Insert the actuator cable through the transom. With the actuator loosely supported, bed the upper mounting bracket and screws with a marine adhesive sealant for use below the waterline. Start the provided #14 x 1-1/4" (3.17 cm) stainless steel sheet metal screws through the upper mounting bracket and into the transom.

MAKE SURE TO LEAVE THE SCREWS ONLY PARTIALLY INSTALLED.

Insert the actuator clevis (mounting ear) into the upper mounting bracket and hold in the approx. installed location. Pass the actuator cable through the transom removing slack on the cable until it **looks like the installation in Fig 2.** Remove the actuator from the upper mounting bracket and finish installing the previously started #14 x 1-1/4" (3.17 cm) stainless steel sheet metal screws through the upper mounting bracket and into the transom.

We recommend using a marine adhesive sealant for use below the waterline to bed the upper mounting bracket and screws. **DO NOT OVERTIGHTEN.** Also bed the screws and cable inside the transom area.

Attach the actuator to the upper mounting bracket using the bolt and nut provided.

Fig 2

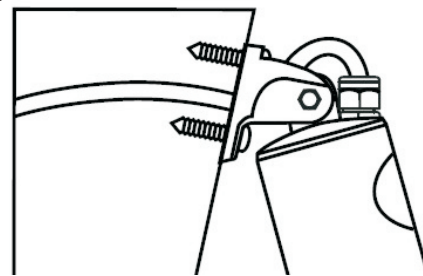

2) You are now ready to attach the Lenco Actuator to the blade. First insert the 1-1/4" Delrin Pin part way through the hole in the Bennett lower mounting bracket and insert through one of the four black washers provided in the kit. Place the actuator into the bracket and tap the pin through. Continue through the second washer and other side of the bracket. Replace the bracket screw. This will lock the pin in place and prevent it from falling out.

Electric RetroFit Kit for Bennett Trim Tabs Installation Instructions Continued

3) Now you will need to hook up the Lenco Actuator wires inside the bilge/rigging area. First cut the wire connector from the Bennett wire harness where the pump used to be. Strip the four harness wires, cut the pins on the four Lenco actuator wires, and strip these four wires. Connect these wires as per the diagram below, using the heat shrink butt splices provided in the kit. Make sure to use the proper crimping tool and then heat all connections for a tight waterproof seal. Tie-wrap or secure in some fashion to a dry location to help prevent the connectors from getting too wet.

Wiring Instructions For Connecting Lenco Actuator Wires to Existing Bennett Rocker Switch

1) Disconnect all wires from the Bennett rocker switch. Remove and discard all brass strips. Reconnect the four wires from the existing Bennett wire harness to the back of the Bennett switch as per the diagram below.

2) Now find a 12 volt negative at the helm/ console. Connect this to the 3' black jumper wire with the non-terminated end. Attach to screw terminal on the back of the Bennett switch as per the diagram below (-12 Volt Black). Attach the orange, black, yellow, red, green, and blue short jumper wires to the back of the Bennett switch as per the diagram below. The 12 volt positive (+) should already be at the switch from the previous system. Simply reconnect it as per the diagram below.

3) Test the trim tabs for proper operation. Remember that the right switch controls the left trim tab and the left controls the right. Bow down should extend the tabs while bow up should retract them. If for some reason this does not work as described in the above text then recheck all the wiring for a misplaced wire. If still not fully operational refer to the trim tab trouble shooting guide in the owners manual for further instructions.

Wiring Diagram for Bennett Rocker Switch

