



RACOR[®]

Parker Hannifin Corporation
Racor Division
PO Box 3208, 3400 Finch Rd
Modesto, CA 95354 USA
209-521-7860/800-344-3286
www.parker.com/racor
racortech@parker.com

Bowl Deflector Kits

RK11868 and RK15104

Warning!

This kit is for use **only** with bowls featuring the SAE J1926 o-ring gland (see below), otherwise a fuel leak may occur leading to a fire. If no gland area is present, order correct bowl kit; 500 Series - RK15279-01, 900 or 1000 Series - RK11-1606-1.

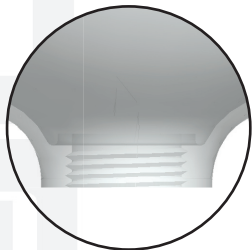

Old Design
(no o-ring gland area)

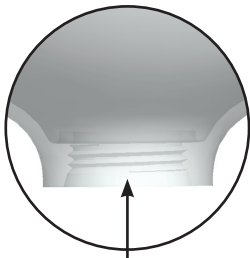

Current Design
(has SAE J1926 o-ring
gland area)

—See Other Side—



Installation Instructions

Partial Cutaway of Marine Turbine Series Assembly

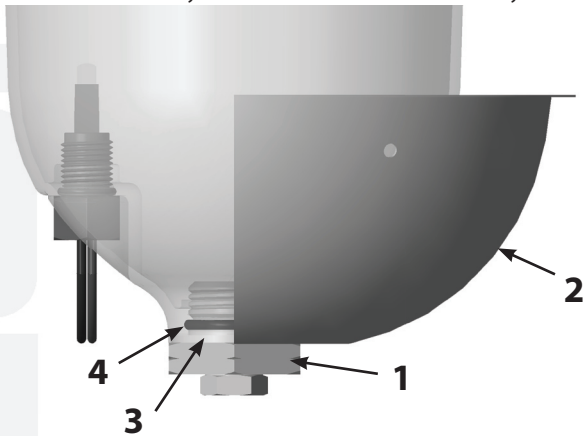

1. Install fitting (item 1) into hole in heat deflector (item 2).
2. Place gasket (item 3) onto locator ridge protruding through inside of heat deflector.
3. Install o-ring (item 4) onto fitting (item 1).
4. Install assembled parts onto bottom of bowl.

Racor's policy is one of continual improvement in design and manufacturing to insure still finer products; therefore, specifications, equipment and product information (while correct at the time of publication) is subject to change without notice. Copyright, Parker Hannifin Corporation, 2005.

Instruction Part Number 11-1839 Revision B