

# ↗ DOMETIC MARINE MAGNETIC-DRIVE PUMPS

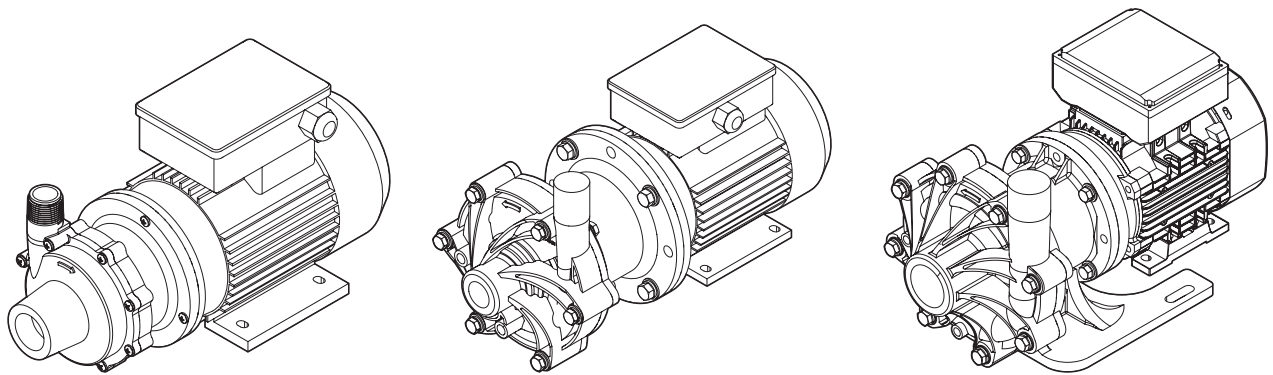

P030, P045, P062, P075, P100, P137, P150, P200

**EN** **Magnetic-Drive Centrifugal Pump**  
Installation and Operation Manual . . . . . 2

<b>⚠ WARNING</b>
Cancer and Reproductive Harm <a href="http://www.P65Warnings.ca.gov">www.P65Warnings.ca.gov</a>



**Service Center & Dealer Locations**

Visit: [www.dometic.com](http://www.dometic.com)

Please read these instructions carefully and follow all instructions, guidelines, and warnings included in this product manual in order to ensure that you install, use, and maintain the product properly at all times. These instructions **MUST** stay with this product.

By using the product, you hereby confirm that you have read all instructions, guidelines, and warnings carefully and that you understand and agree to abide by the terms and conditions as set forth herein. You agree to use this product only for the intended purpose and application and in accordance with the instructions, guidelines, and warnings as set forth in this product manual as well as in accordance with all applicable laws and regulations. A failure to read and follow the instructions and warnings set forth herein may result in an injury to yourself and others, damage to your product, or damage to other property in the vicinity. This product manual, including the instructions, guidelines, and warnings, and related documentation, may be subject to changes and updates. For up-to-date product information, please visit [www.dometic.com](http://www.dometic.com).

**Contents**

- 1 Explanation of Symbols and Safety Instructions . . . . . 2**
  - 1.1 Recognize Safety Information . . . . . 2
  - 1.2 Understand Signal Words . . . . . 2
  - 1.3 Supplemental Directives . . . . . 3
  - 1.4 General Safety Messages . . . . . 3
- 2 Intended Use . . . . . 4**
- 3 General Information . . . . . 5**
- 4 Specifications . . . . . 5**
  - 4.1 Maximum Surface Temperature . . . . . 5
  - 4.2 Minimum Flow Rate . . . . . 5
- 5 Installation . . . . . 6**
  - 5.1 Selecting the Pump Location . . . . . 6
  - 5.2 Rotating the Pump Head (Optional) . . . . . 6
  - 5.3 Mounting the Pump . . . . . 8
  - 5.4 Connecting the Piping . . . . . 8
  - 5.5 Connecting a Drain Plug or Valve (Optional) . 9
  - 5.6 Making the Electrical Connections . . . . . 9
- 6 Operation . . . . . 9**
  - 6.1 Priming the Pump . . . . . 9
  - 6.2 Starting the Pump . . . . . 9

- 6.3 Verifying the Rotation of the Motor . . . . . 10
- 6.4 Shutting Down the Pump . . . . . 10
- 7 Maintenance . . . . . 10**
  - 7.1 Recommended Maintenance Schedule . . . 10
  - 7.2 Flushing and Draining the Pump . . . . . 10
  - 7.3 Disassembling the Pump . . . . . 11
  - 7.4 Inspecting the Pump Components . . . . . 13
  - 7.5 Installing Pump Wear Kit (Optional) . . . . . 13
  - 7.6 Installing a Pump Wet End Replacement Kit (Optional) . . . . . 14
  - 7.7 Reassembling the Pump . . . . . 14
- 8 Troubleshooting . . . . . 16**
- 9 Disposal . . . . . 16**
- 10 Warranty Information . . . . . 16**

**1 Explanation of Symbols and Safety Instructions**

This manual has safety information and instructions to help you eliminate or reduce the risk of accidents and injuries.

**1.1 Recognize Safety Information**

 **This is the safety alert symbol.** It is used to alert you to potential physical injury hazards. Obey all safety messages that follow this symbol to avoid possible injury or death.

**1.2 Understand Signal Words**

A signal word will identify safety messages and property damage messages, and also will indicate the degree or level of hazard seriousness.

 **DANGER!**  
Indicates a hazardous situation that, if **not** avoided, will result in death or serious injury.

 **WARNING**  
Indicates a hazardous situation that, if **not** avoided, could result in death or serious injury.

**⚠ CAUTION**

Indicates a hazardous situation that, if **not** avoided, could result in minor or moderate injury.

**NOTICE:** Used to address practices **not** related to physical injury.

**i** Indicates additional information that is **not** related to physical injury.

## 1.3 Supplemental Directives

To reduce the risk of accidents and injuries, please observe the following directives before proceeding to install or operate this product:

- Read and follow all safety information and instructions.
- Read and understand these instructions before installing or operating this product.
- The installation must comply with all applicable local or national codes, including the latest edition of the following standards:

**U.S.A.**

- ANSI/NFPA70, National Electrical Code (NEC)
- American Boat and Yacht Council (ABYC)

**Canada**

- CSA C22.1, Parts I & II, Canadian Electrical Code

## 1.4 General Safety Messages

**⚠ WARNING: MAGNETIC HAZARD. Failure to obey the following warnings could result in death or serious injury:**

- Individuals with cardiac pacemakers, implanted defibrillators, other electronic medical devices, metallic prosthetic heart valves, internal wound clips (from surgery), metallic prosthetic devices or sickle cell anemia **must not** handle or be in the proximity of the magnets inside this pump. Consult a health care provider before working with this pump.
- Do **not** place fingers between the mating surfaces of the motor and wet end of this pump. The magnetic force is powerful enough to rapidly pull the motor end and the wet end together.

**⚠ WARNING: ELECTRICAL SHOCK, FIRE, AND/OR EXPLOSION HAZARD. Failure to obey the following warnings could result in death or serious injury:**

- Use only Dometic replacement parts and components that are specifically approved for use with the product.
- Avoid improper installation, adjustment, alterations, service, or maintenance of the product. Service and maintenance **must** be done by a qualified service person only.
- Do **not** modify this product in any way. Modification can be extremely hazardous.
- Before attempting to make any electrical connections, ensure the electrical power is off and the water valves are completely closed.
- Secure and seal all wire connections to protect from arcing.
- Do **not** operate the pump in a highly-explosive environment unless the pump has a label to indicate it is rated for ignition protection. Refer to labeling on the pump to determine the environmental limitations for operation near gasoline or other explosives.
- Do **not** pump flammable or combustible liquids.
- Disconnect the pump from the power supply before cleaning and/or servicing. Maintenance **must** be done by a qualified service person only.

**⚠ WARNING: FLOOD/LEAK HAZARD. Failure to obey the following warnings could result in death or serious injury.**

- Do **not** perform service or maintenance when the pumping system is pressurized.
- Do **not** mount the pump such that high piping loads exist on the pump connections, or in a rigid system that does not allow the pipe to expand, causing the pump to be strained.
- Do **not** operate the pump beyond the pressure or temperature limits.
- Do **not** allow severe temperature changes to occur in a short time period within the pumping system.
- Do **not** continue to operate the pumping system when a known leak exists.

**⚠ WARNING: IMPACT HAZARD.**

This pump has components that rotate while in operation. Follow local safety standards for locking out the motor from the power supply during maintenance or service. Failure to obey this warning could result in death or serious injury.

**WARNING: BURN HAZARD.**

Do **not** touch the surface of the pump during operation or before cool down. This pump can handle liquids up to 180 °F (82 °C). This may cause the pump to become hot and could cause burns. Failure to obey this warning could result in death or serious injury.

**⚠ WARNING: CHEMICAL HAZARD. Failure to obey the following warnings could result in death or serious injury.**

- Always wear protective clothing and eye protection when handling chemicals that may be used to operate or maintain this pump.
- Follow standard safety procedures when handling corrosive or personally harmful materials that may be used with this pump.
- Follow proper procedures for draining and decontaminating the pump before performing maintenance on it.

**⚠ WARNING: LIFTING HAZARD.**

This pump and associated components are heavy. Do **not** attempt to lift or move the pump without adequate support. Failure to obey this warning could result in death or serious injury.

**NOTICE:** Failure to obey the following instructions could result in damage to the pump or components, and cause property damage.

- Keep the drive magnet and impeller assembly away from metal chips or particles, and items with magnetic stripes like credit cards and magnetic computer media such as floppy discs and hard drives.
- Do **not** lift or move the pump without support. The pump and components are heavy.
- Do **not** continue to operate the pump when unusual noise or vibration occurs.
- Do **not** run the pump at less than the minimum flow. This could lead to a pump failure.

- Do **not** continue to operate the pumping system when a known leak exists.
- Do **not** operate the pump without liquid in the casing. The exact length of time the pump can operate dry without damage varies with operating conditions and the environment.
- Do **not** start or operate the pump with a closed suction valve.
- Do **not** operate the pump with a closed discharge valve. This could lead to pump failure.
- Always provide adequate NPSHa (net positive suction head available). It is recommended to provide at least 24 in. (61 cm) above the NPSHr (net positive suction head required).
- If the pump is used on variable speed drive, do **not** exceed the frequency for which the pump was designed (for example, if the pump is a 50 Hz model, do not exceed 50 Hz).
- Ground the pump to prevent static discharge. Before operating the pump, ensure the electrical continuity throughout the pumping system and earth ground is 1 Ohm or less.
- Check the pump for leaks on a regular basis. If leaks are noticed, immediately repair or replace the pump.
- Clean the pump regularly to prevent dust build up.
- Do **not** check the rotation of the motor without filling the pump full of liquid, opening the suction and discharge lines, and removing air from the lines.
- Use of a power monitor is strongly recommended for pumps. The power monitor will stop the pump and help prevent damage if the pump should run dry.

## 2 Intended Use

This Dometic Magnetic-Drive (Mag-Drive) Centrifugal Pump (also referred to as the “pump” or the “product”) is marine grade, intended for use with sea or nonpotable water.

Pumps are designed to encompass a wide range of applications and configurations. The installer determines various installation factors to fit the application, such as:

- Pump head orientation (horizontal or vertical)

- Mounting location (directly to floor plates, rails with vibration isolators to reduce noise, platforms, etc.)
- Suitable mounting hardware for desired installation or use
- Suitable piping for desired installation or use (for example: Schedule 80 PVC, CPVC, copper piping, stainless steel, flexible hose, etc.)
- Single-phase or three-phase electrical wiring

This manual provides all necessary information for proper installation and operation of the pump. Poor installation and improper operating procedures will result in unsatisfactory performance and possible failure. The manufacturer accepts no liability for damage in the following cases:

- Faulty assembly or connection
- Damage to the product resulting from mechanical influences and excess voltage
- Alterations to the product without express permission from the manufacturer
- Use for purposes other than those described in this manual

Dometic Corporation reserves the right to modify appearances and specifications without notice.

### 3 General Information

**i** The images used in this document are for reference purposes only. Components and component locations may vary according to specific product models.

Recommended Tools and Materials	
Wire Strippers and Crimper	Phillips-head Screwdriver
Weatherproof Wire Nuts	Socket Wrenches
Other hardware sufficient for secure mounting at desired location	<ul style="list-style-type: none"> <li>• 5/16 in. (8 mm)</li> <li>• 3/8 in. (9 mm)</li> <li>• 1/2 in. (13 mm)</li> <li>• 5/8 in. (16 mm)</li> <li>• 3/4 in. (19 mm)</li> </ul>

#### Additional Tools and Materials for Optional Steps

Drill Press	Waterproof Pipe Sealant or Tape
7/16 in. Drill Bit	Drain Plug or Valve
1/4 in. NPT Tap	Waterproof Electrical Tape
Arbor Press	Plastic or Wooden Shaft

## 4 Specifications

The major pump parts are glass-filled polypropylene for superior corrosion resistance.

**i** For best performance, maintain operation of this pump within the following specifications. Additional specifications for each pump are available online at [www.dometic.com](http://www.dometic.com).

### 4.1 Maximum Surface Temperature

The maximum allowable surface temperature of the pump is 180 °F (82 °C).

### 4.2 Minimum Flow Rate

See the table below for the minimum flow rates by model.

Model	3450 rpm	2900 rpm
<b>P030</b>	0.3 gpm (.9 lpm)	0.3 gpm (.9 lpm)
<b>P045 P062 P075 P100</b>	0.5 gpm (1.9 lpm)	0.5 gpm (1.9 lpm)
<b>P137</b>	4 gpm (15 lpm)	3.4 gpm (12.9 lpm)
<b>P150</b>	5 gpm (18.9 lpm)	4.2 gpm (15.9 lpm)
<b>P200</b>	10 gpm (37.8 lpm)	10 gpm (37.8 lpm)

## 5 Installation

**NOTICE:** Failure to obey the following instructions could result in damage to the pump or components, and cause property damage.

- The motor is splash-resistant, not submersible. It should be located in a dry environment.
- The pump outlet **must** be above the inlet.
- **Never** install the pump vertically or with the motor below the pump.
- If the pump was packaged with plastic shipping shims, these shims **must** be used as additional support under the motor feet.
- The Net Positive Suction Head available (NPSHa) to the pump **must** be greater than the Net Positive Suction Head required (NPSHr). NPSHa is the pressure measured to the inlet of the pump. NPSHr is a value that can be found on the pump spec sheet curves. Filters, strainers and any other fittings in the suction line will lower the NPSHa and should be calculated into the application.

This section describes how to select the pump location, how to rotate the pump head (if needed to accommodate the discharge piping), mounting the pump, connecting the piping, connecting a drain plug or valve, and making the electrical connections.

### 5.1 Selecting the Pump Location

When selecting the pump location, consider the following items.

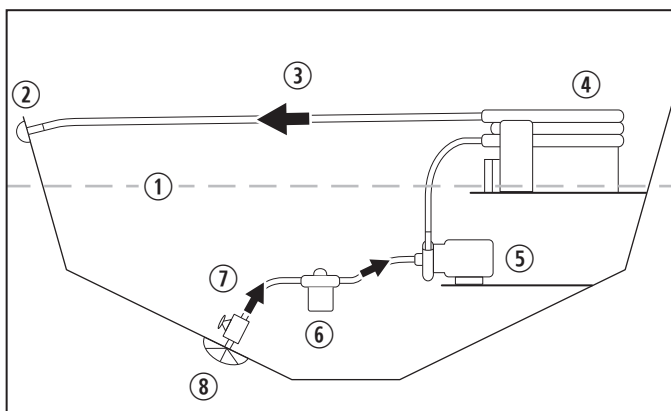

**1** Pump Placement - Sea or Nonpotable Water Application

- |                      |   |
|----------------------|---|
| ① Water Line         | ⑥ Strainer  |
| ② Seawater Outlet    | ⑦ Inlet Flow  |
| ③ Outlet Flow        | ⑧ Seacock (ball valve) and Scoop-type, Through-hull Inlet |
| ④ A/C Condenser Coil |   |
| ⑤ Pump               |   |

- For optimum performance and to minimize suction lift, place the pump as far below the water line as possible.
- Place the pump in a location that will allow mounting in a level, horizontal position, on a secure foundation.
- Ensure adequate ventilation around the pump for proper operation and cooling of the motor.

### 5.2 Rotating the Pump Head (Optional)

The pump is preconfigured with a vertical discharge orientation, which is applicable to most installations. When preparing the pump installation, it may be necessary to rotate the pump head to improve the ease of installing the pump and associated piping. Rotating the pump head is optional, and should be done before mounting the pump.

- i** Make sure the o-ring is properly seated in the groove after rotating. The o-ring is lubricated, and should not need additional lubrication.
- i** When the pump discharge is in a horizontal configuration, the motor must be shimmed to raise the front of the pump to avoid interference.

### 5.2.1 P030 Model

Use the following instructions to rotate the pump head on the P030 model.

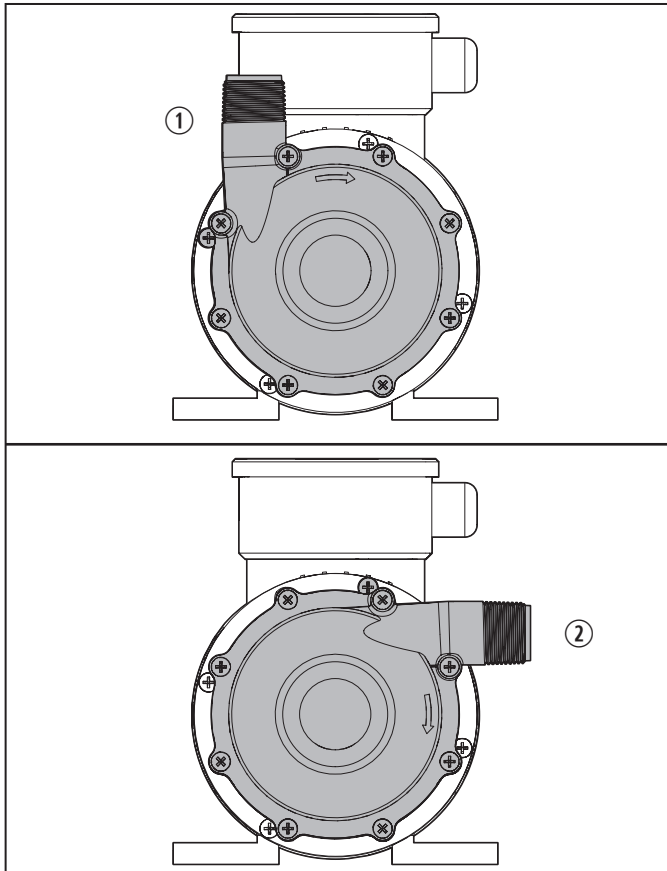

**2** P030 Discharge Orientations

① Vertical Discharge      ② Horizontal Discharge

1. Place the motor in an upright position, resting on the fan end of the motor.
2. Remove the eight screws from the pump housing.
3. Pull the housing away from the motor adapter/barrier.
4. Rotate the housing 90°, aligning the screw holes on the housing and motor adapter/barrier.
5. Push down on the housing to seat it on the motor adapter/barrier.
6. Reinstall the screws.

### 5.2.2 P045, P062, P075, P100, P137, P150, and P200 Models

Use the following instructions to rotate the pump head on the P045, P062, P075, P100, P137, P150, and P200 models.

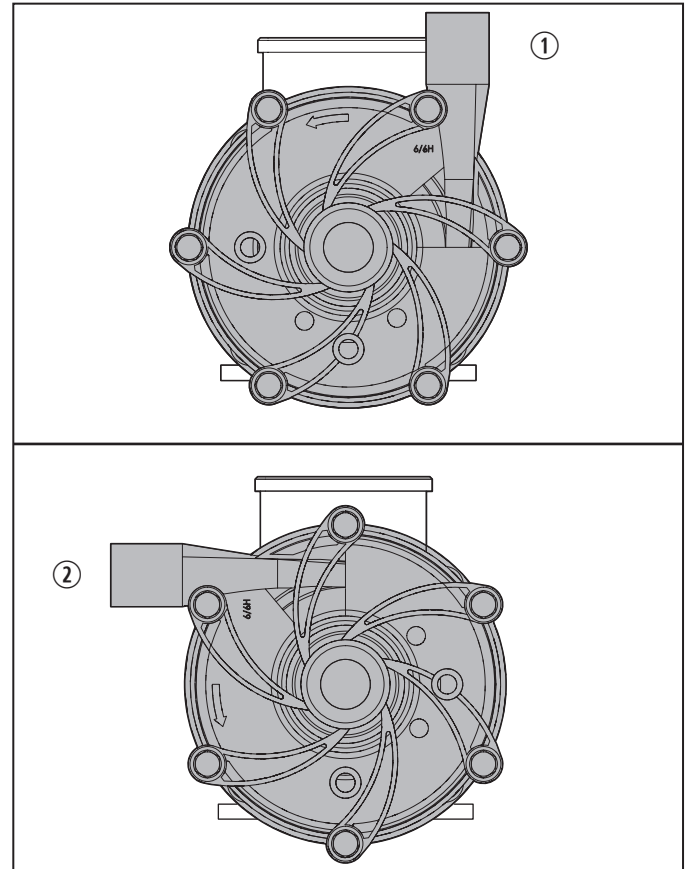

**3** P045, P062, P075, P100, P137, P150, and P200 Discharge Orientations

① Vertical Discharge      ② Horizontal Discharge

1. Remove the four clamp ring bolts, lock washers, and flat washers.
2. Rotate the clamp ring 90°, aligning the holes on the clamp ring and motor adapter/barrier.
3. Reinstall the clamp ring bolts, lock washers, and flat washers.

## 5.3 Mounting the Pump

Use the following instructions to securely mount the pump in the desired location.

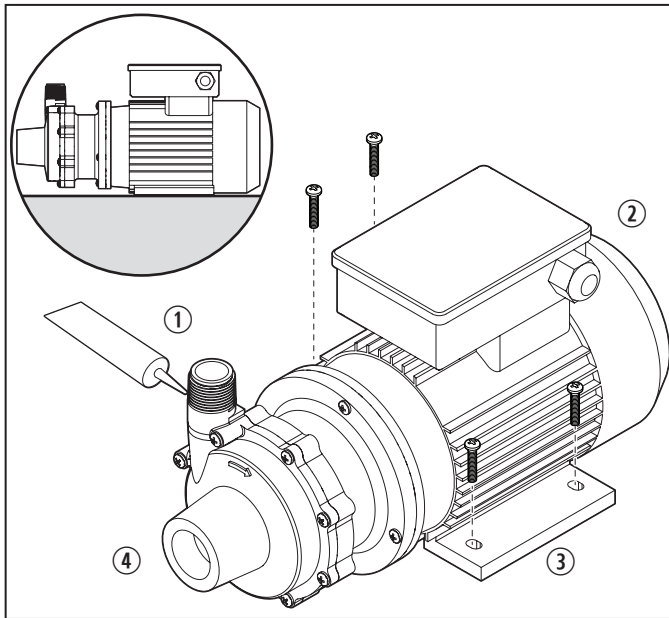

**4** Mounting With Vertical Discharge Orientation (P030 Shown)

- |           |             |
|-----------|-------------|
| ① Sealant | ③ Foot      |
| ② Motor   | ④ Pump Head |

1. Place the pump motor in the desired location and mark the position of the mounting holes.
2. Drill holes for the mounting screws.
3. If the pump was packaged with plastic shipping shims, place the shims under the motor feet.
4. Tighten the screws to secure the pump into position.
5. Use an appropriate pipe sealant or tape on the threads and other piping connections.
6. Tighten all connections, using appropriate tools for the selected piping materials.

## 5.4 Connecting the Piping

Use the following guidelines for connecting the piping.

- Place the piping with independent support near the pump to eliminate any strain on the pump casing.
- A strainer on the inlet pipe should be used to remove debris before the liquid enters the pump.

- Position the piping on the suction side of the pump in a straight and short configuration to minimize pipe friction.
  - Keep bends and valves at least ten pipe diameters away from the suction and discharge.
  - Install the suction piping to be level or sloping slightly upward toward the pump. To prevent air pockets, the suction line should not have any high spots.
  - The suction line should be at least as large as the suction inlet port or one pipe size larger so that it does not affect the NPSHa. Do not reduce the suction line size.
  - A check valve and control valve (if used) should be installed on the discharge line. The check valve helps prevent the pump from water hammer damage. This is particularly important when the static discharge head is high. The control valve is used for regulating flow.
  - Isolation valves on the suction and discharge lines can be used to make the pump accessible for maintenance.
  - If flexible hose is preferred, use a reinforced hose rated for the proper temperature, pressure and chemical resistance against the fluid being pumped.
  - Use an appropriate pipe sealant or tape on the threads and other piping connections.
  - The suction valve must be completely open to avoid restricting the suction flow.
  - A flush system in the piping can be installed to allow the pump to be flushed before it is removed from service.
- i** P062, P075, P100, P137, P150, and P200 pump models are provided with a provision for a customer-installed 1/4 in. (6 mm) drain in the impeller housing. For the best performance, ensure the pump piping is sized appropriately for the flow rate.



## 5.5 Connecting a Drain Plug or Valve (Optional)

A drain plug or valve can be installed in the impeller housing to provide the ability to connect a drain line for removing fluids before servicing the pump. The following instructions explain how to connect an optional drain plug or valve on the P062, P075, P137, P150, and P200 models.

1. Clamp the impeller housing to a drill press table.
2. Using a 7/16 in. drill and the molded boss as a guide, drill completely through the molded boss into the interior of the impeller housing.
3. Using a 1/4 in. NPT tap, tap the hole in the molded boss to the appropriate depth.

**i** Do not tap too deep or the impeller housing may be damaged.

4. Install the drain plug or valve, being careful not to over-tighten.

## 5.6 Making the Electrical Connections

**NOTICE:** When installing the pump, follow these important considerations regarding the electrical connections. Failure to follow the practices listed could result in damage to the pump.

- Prior to connecting to the power line, check the nameplate voltage and rotation connection, and ensure proper grounding.
- Check the pump voltage, frequency, and phase to ensure it matches the installation power source.
- Do not use or install the pump if the voltage, frequency, phase, and amp on the label are different from the supply circuit.
- Protect the motor with a fuse or circuit breaker. For three-phase motors, protect the motor with a phase-failure protection device.
- Some pumps are dual-voltage and will need to be wired to the specific voltage for your application.

- If utilized, verify that power monitors or variable frequency drives have been properly installed according to the manufacturer's instructions.
- Follow National Electric Code, NEMA MG-2, IEC, and ABYC standards, requirements, and local electrical codes.

**i** Refer to the wiring diagram affixed to the pump.

## 6 Operation

**NOTICE:** This pump **must** be filled with liquid. Failure to prime the pump before operation could result in damage to the pump and components.

Follow the steps in this section for priming and starting the pump, verifying the motor rotation, and shutting down the pump.

### 6.1 Priming the Pump

**i** This pump is not self priming. Mounting the pump below the water line helps prime the pump head.

1. Connect the external liquid source to the pump.
2. Open the inlet (suction) and discharge valves completely and allow the pump to fill with liquid.

### 6.2 Starting the Pump

1. Ensure all valves are open and the pump connections are secure. The pump requires positive suction at the pump head to prevent cavitation.
2. Close the discharge valve.
3. Turn the pump on.
4. Slowly open the discharge valve. Adjust the flow rate and pressure by regulating the discharge valve.

**i** Do not attempt to adjust the flow with the suction valve.

## 6.3 Verifying the Rotation of the Motor

1. Allow the motor to run for 1-2 seconds and observe the rotation of the motor fan.
2. Refer to the directional arrow molded into the pump casing or the rotational sticker at the rear of the pump motor. If the motor rotation direction matches the direction the arrows are pointing, rotation is correct. If the rotation is incorrect, check the wiring diagram on the pump and resolve wiring issues.

**i** A pump running backwards will pump but at a greatly reduced flow and pressure.

## 6.4 Shutting Down the Pump

1. Turn off the motor.
2. Slowly close the discharge valve.
3. Close the suction valve.

# 7 Maintenance

**NOTICE:** Failure to properly maintain the pump may void the warranty and could result in unsafe operation. Preventive maintenance is **not** covered under the warranty.

**NOTICE:** Before performing maintenance on this pump, it **must** be flushed and drained of all fluids.

The following maintenance and cleaning instructions should be performed at the intervals indicated, or as needed, depending on the use of the pump.

## 7.1 Recommended Maintenance Schedule

The recommended maintenance schedule depends upon the nature of the fluid being pumped and the specific application.

- If the pump is used on a clean fluid, remove the pump from service and perform an inspection after six months, or after 2,000 hours of operation.

- If the pump is used on fluids with solids, high temperatures, or other items that could cause accelerated wear, then this initial examination should be sooner.
- For the best results, remove the pump from service at least annually for disassembly and inspection.

After the initial examination of the internal components and wear items are measured, a specific maintenance schedule can be determined.

## 7.2 Flushing and Draining the Pump

**i** Drain the pump of fluids to remove internal pressure before performing maintenance.

1. Follow the proper shut down procedure. Refer to “Shutting Down the Pump” on page 10 for instructions.
2. Connect the flushing fluid supply to the inlet valve.
3. Connect the flushing fluid drain to the discharge valve.
4. Open the flushing inlet and discharge valves.
5. Direct the flushing liquid into the system until the pump is clean.
6. Stop the flow of flushing liquid and allow the pump to drain of all fluids.

### 7.3 Disassembling the Pump

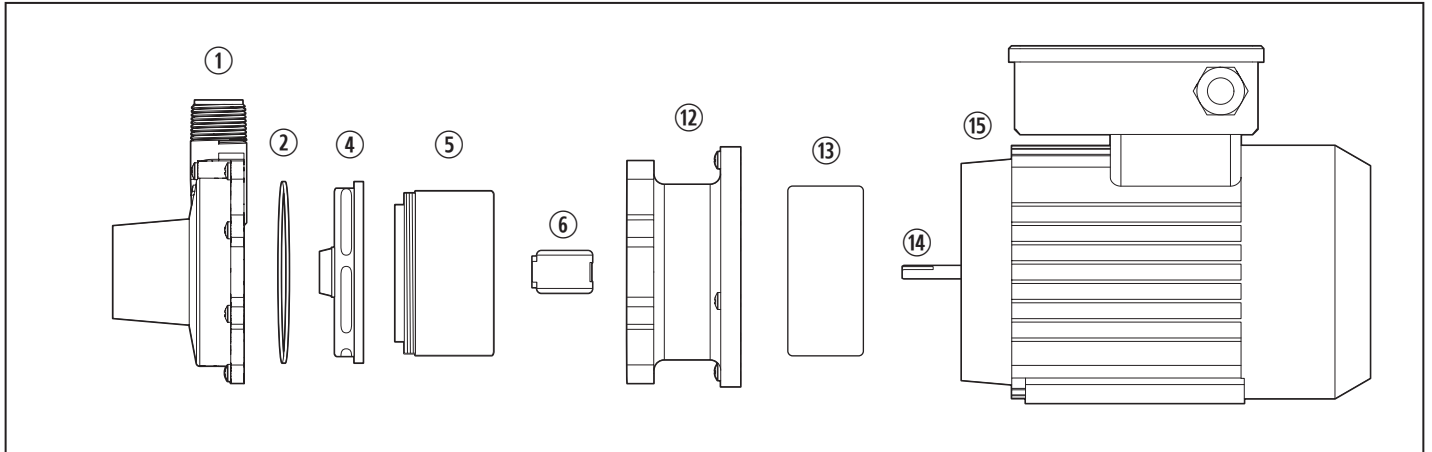

5 Exploded View - P030

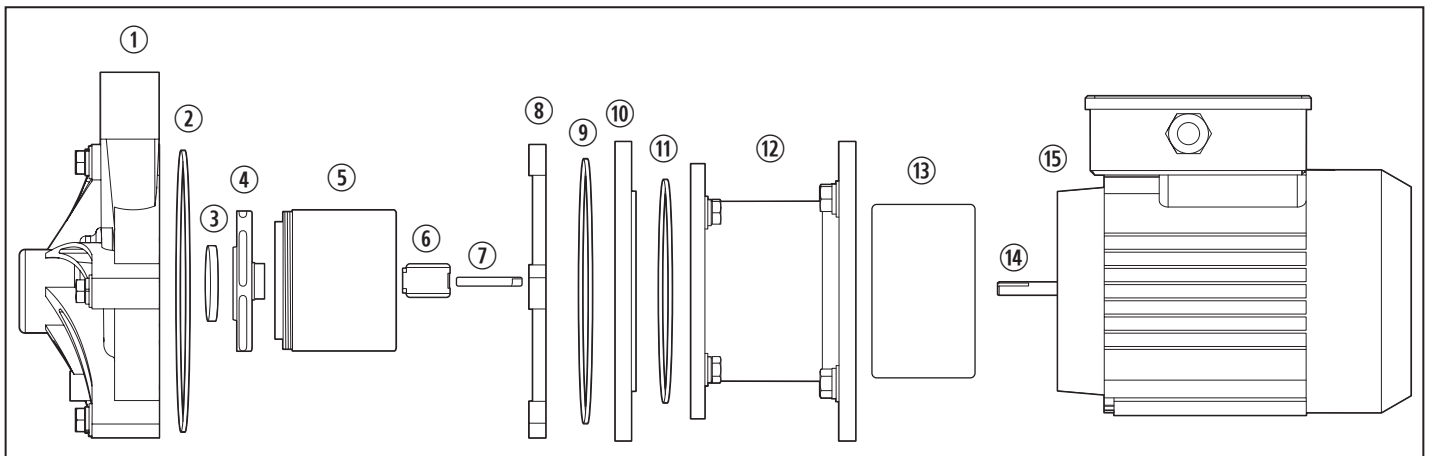

6 Exploded View - P045, P062, P075, P100

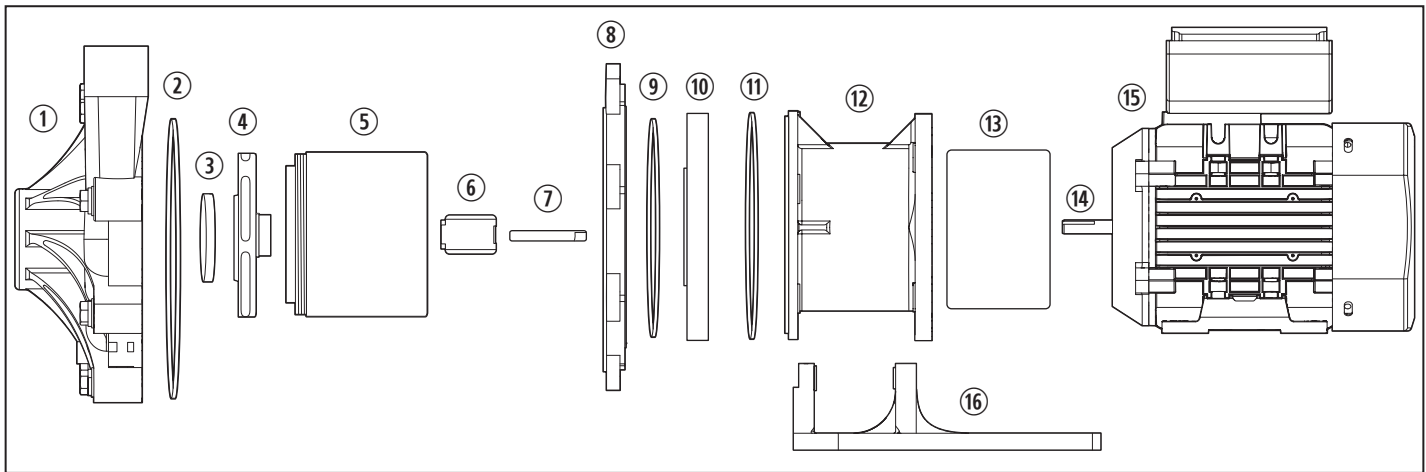

7 Exploded View - P137, P150, P200

- |                        |                           |                                     |                               |
|------------------------|---------------------------|-------------------------------------|-------------------------------|
| ① Pump Housing         | ⑤ Impeller Drive Assembly | ⑨ Barrier O-Ring                    | ⑬ Outer Drive Magnet          |
| ② Housing O-Ring       | ⑥ Impeller Bushing        | ⑩ Clamp Ring (not included on P200) | ⑭ Motor Shaft                 |
| ③ Impeller Thrust Ring | ⑦ Impeller Shaft          | ⑪ Clamp O-Ring                      | ⑮ Motor                       |
| ④ Impeller Assembly    | ⑧ Motor Barrier           | ⑫ Motor Adapter                     | ⑯ Foot (not included on P200) |

- Shut down the pump, lock out the motor from the power supply, flush the pump, and drain all fluid. Refer to “7.2 Flushing and Draining the Pump” on page 10.
  - For small pumps 2 hp (1.5 kW) or less, place the pump and motor in an upright position on the fan end of the motor or securely clamp the foot to a workbench. For larger pumps with 3 hp (2.2 kW) or greater, place the pump securely on the floor with the pump head facing up.
  - Remove the screws or bolts and lock-washers (if present) securing the pump head to the motor adapter/barrier. Use tools appropriate for the fasteners installed. (The P030 motor adapter includes the barrier, while other models have a separate motor barrier and motor adapter.)
  - Firmly hold one side (either the pump head or the motor, depending on the size and weight of the model) and pull straight out to disengage the pump head and motor. If the pump head has the optional o-ring seal, make sure the o-ring remains on the motor adapter.
  - Place the pump head on a workbench with the housing facing up.
  - Remove the screws or bolts on the outside of the pump housing. The number of housing fasteners depends on the pump model.
  - Firmly hold the pump housing and pull straight up to remove it from the pump head.
  - Remove the impeller thrust ring, the impeller assembly, the impeller drive assembly, and the impeller bushing.
  - Remove the impeller shaft. On the P030, the impeller shaft is attached to the motor adapter. For all other models, the impeller shaft is attached to the motor barrier.
  - Remove the motor barrier and barrier o-ring (if present) from the motor adapter. If necessary, gently tap on the backside of the motor barrier with a soft wooden or plastic rod to dislodge it. (This step does not apply to the P030.)
  - Remove the clamp ring and clamp o-ring from the motor adapter. (This step does not apply to the P030.)
- i** Nuts may become bonded to the studs over time. Tightening the nuts before removal ensures the studs do not back out of the pump head.

## 7.4 Inspecting the Pump Components

- Check the pump housing for signs of wear or damage. Look for signs of rubbing, cracking on thrust ring, or damage to the front shaft support.
- Check the impeller, drive, thrust ring, bushing, and running surface between the impeller and the pump head for wear.
- Replace the bushing if wear causes the dimensions of the bushing to exceed the maximum diameter limit. Refer to “Impeller Bushing Wear Tolerance” on page 13 for acceptable dimensions.
- Check the inside and outside of the motor barrier for wear or signs of rubbing.
- Check the outer drive for rubbing, damage, corrosion, or loose magnets.
- Check the o-ring for chemical attack, swelling, brittleness, cuts, or other damage. Replace the o-ring if it is worn or damaged.
- Check the clamp ring for wear. If it is damaged, it should be replaced.
- Clean the parts that are to be reused using a mild cleanser. Remove any abrasive material.
- Check the motor shaft for wear at the seal. If it shows signs of wear, replace the pump.
- Check the motor bearings by rotating the motor manually. If the shaft rotation is not smooth or has radial/axial end-play, replace the pump.

**i** If needed, contact Dometic Customer Support for a pump wear kit or pump wet end replacement kit.

### 7.4.1 Impeller Bushing Wear Tolerance

Use the following diagram and table to determine the wear on the impeller bushing. If the measured inner diameter exceeds the maximum tolerance, replace the bushing.

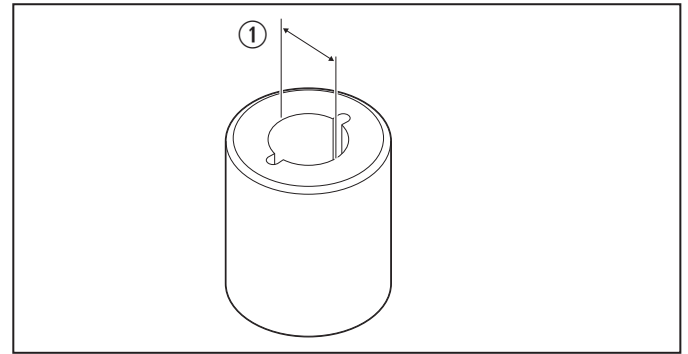

**8** Impeller Bushing Wear Tolerance

Model	① Maximum Impeller Bushing Inner Diameter
P030 P045 P062 P075 P100	0.415 in. (10.5 mm)
P137 P150	0.515 in. (13.1 mm)
P200	0.780 in. (19.8 mm)

## 7.5 Installing Pump Wear Kit (Optional)

If the impeller bushing must be replaced, follow the instructions below to install the impeller bushing wear replacement kit (sold separately) before reassembly.

1. Place the impeller/inner drive assembly with the impeller facing up in an arbor press. If necessary support the bottom of the assembly with blocks to allow the bushing to fall out.
2. Insert a 1 in. (25 mm) diameter plastic or wooden shaft through the impeller and press the bushing out.
3. Remove the impeller assembly from the arbor press.
4. Place the impeller assembly on a flat surface with the impeller thrust ring face down.
5. With the slotted face of the replacement bushing facing the rear of the inner drive, align the flat in the bushing with the flat in the inner drive magnet.
6. Gently push the bushing into the inner drive until the bushing bottoms out.
7. Follow the instructions in “7.7 Reassembling the Pump” on page 14 to reassemble the pump.

## 7.6 Installing a Pump Wet End Replacement Kit (Optional)

If any of the pump components besides the impeller bushing require replacement, follow the instructions below to install the pump wet end replacement kit before reassembling the pump. This kit is sold separately. It includes the pump head that attaches to the motor.

1. For small pumps 2 hp (1.5 kW) or less, place the pump in an upright position on the fan end of the motor or securely clamp the pump feet to a workbench. For larger pumps with 3 hp (2.2 kW) or greater, place the pump and motor securely on the floor with the pump head facing up.
2. Remove the screws or bolts and lock-washers (if present) securing the pump head to the motor adapter/barrier. Use tools appropriate for the fasteners installed.
3. Firmly hold the pump head (or the side that is not clamped) and pull straight out to disengage the pump head and motor.
4. Align the holes on the replacement pump wet end assembly with the holes on the motor adapter.
5. Install the screws or bolts and lock washers (if present).

**i** Refer to Figure 9, 10, or 11 on page 1514-15 (depending on the pump model) for a reassembly diagram.

## 7.7 Reassembling the Pump

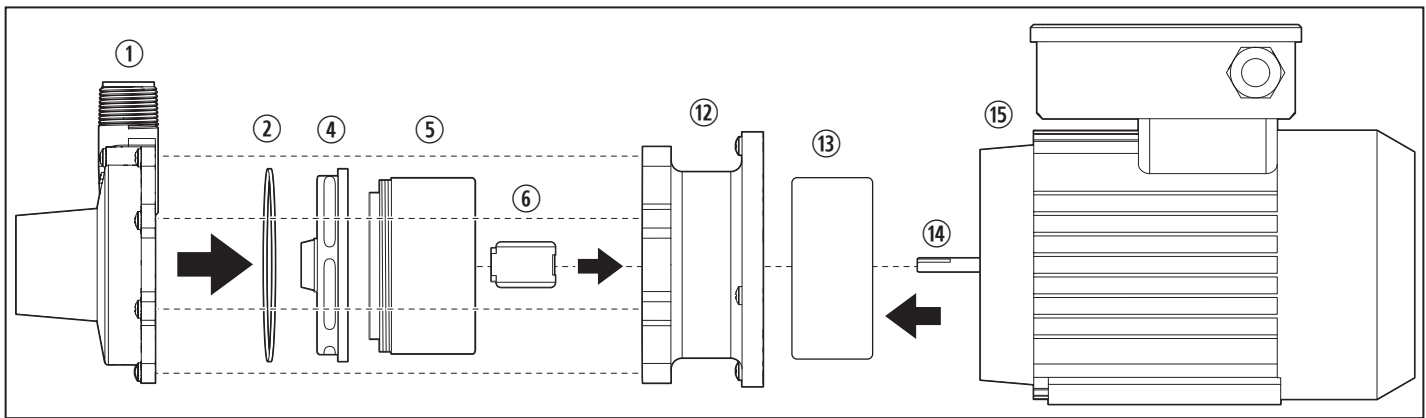

**9** P030 Reassembly

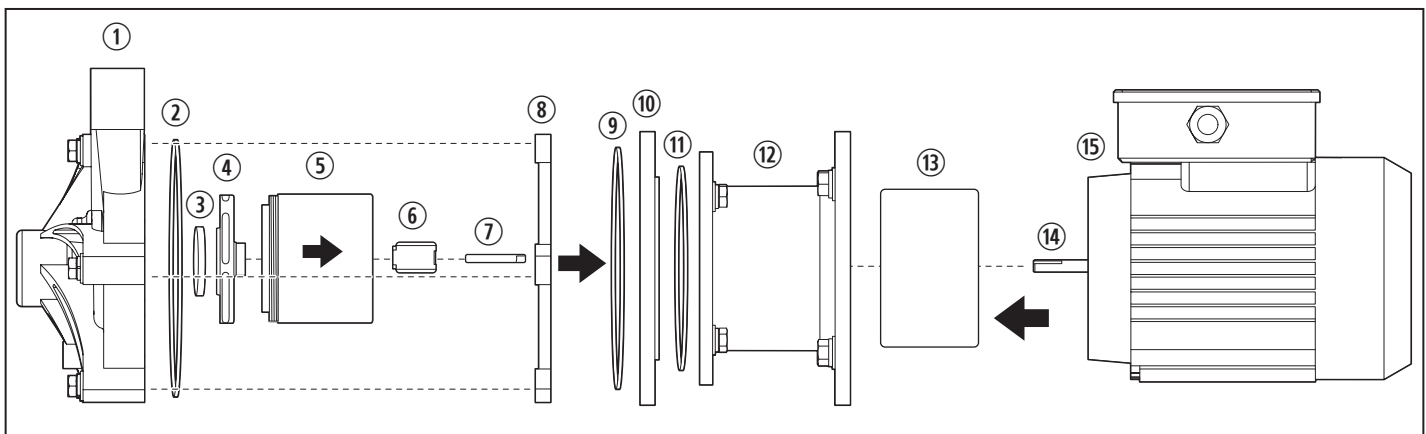

**10** P045, P062, P075, P100 Reassembly

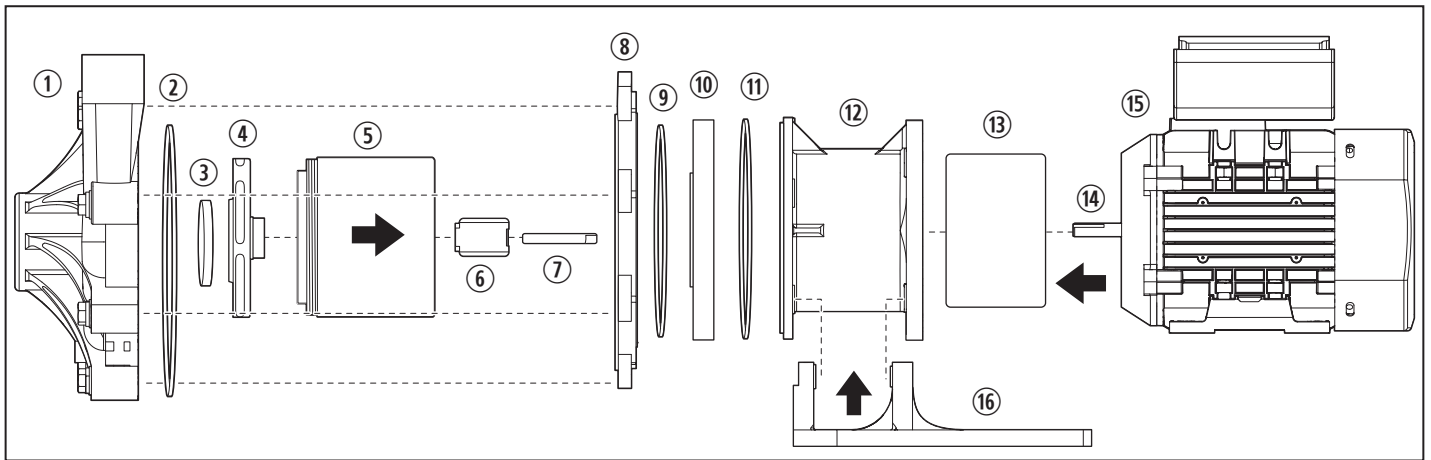

### 11 P137, P150, P200 Reassembly

- |                        |                           |                                     |                               |
|------------------------|---------------------------|-------------------------------------|-------------------------------|
| ① Pump Housing         | ⑤ Impeller Drive Assembly | ⑨ Barrier O-Ring                    | ⑬ Outer Drive Magnet          |
| ② Housing O-Ring       | ⑥ Impeller Bushing        | ⑩ Clamp Ring (not included on P200) | ⑭ Motor Shaft                 |
| ③ Impeller Thrust Ring | ⑦ Impeller Shaft          | ⑪ Clamp O-Ring                      | ⑮ Motor                       |
| ④ Impeller Assembly    | ⑧ Motor Barrier           | ⑫ Motor Adapter                     | ⑯ Foot (not included on P200) |

1. Place the clamp o-ring on the clamp ring, and install it on the motor adapter. Press firmly to ensure a tight seal. (This step does not apply to the P030).
  2. Place the barrier o-ring on the motor barrier and install it on the motor adapter. (This step does not apply to the P030).
  3. Install the impeller shaft, aligning the flats on the shaft with the ones in the motor barrier. Make sure the impeller shaft is completely seated in the motor barrier. (This step does not apply to the P030).
  4. Assemble the impeller thrust ring, the impeller drive assembly, and the impeller bushing. (The P030 impeller assembly has the thrust ring and drive assembly included within it.)
  5. Place the housing o-ring in the groove on the pump housing and apply an oil-free lubricant.
  6. Install the pump housing onto the pump, making sure the discharge is in the correct orientation for the installation.
  7. Holding the pump housing with one hand, install and finger-tighten two bolts or screws and washers (if present) in opposite locations.
  8. Install the remaining pump housing fasteners and finger-tighten.
  9. Use a socket wrench or screwdriver (depending on fasteners) to tighten all bolts evenly using a star pattern.
- i** Refer to Figure 9, 10, or 11 on page 1514-15 (depending on the pump model) for a reassembly diagram.

## 8 Troubleshooting

Use the instructions that follow to resolve occurrences that are not a result of defective workmanship or materials.

Problem	Possible Cause	Recommended Solution
The flow is insufficient or nonexistent.	There is an air leak in the suction piping.	Check the pipe connections and tighten the seals.
	The pump has not been primed.	Ensure the pump head is filled with fluid before starting.
	The system head is higher than expected.	Check the application requirements; a larger pump may be required.
	There is a closed valve.	Open the suction and discharge valves.
	The viscosity or specific gravity is too high.	Check the fluid mixture concentrations.
	The suction lift is too high or there is insufficient NPSH.	Ensure the proper inlet pressure. The pump should be either below water level or in a fully pressurized loop.
	There is a clogged suction line or impeller vane.	Check the inlet strainer and pump lines, and remove debris.
	The motor is rotating incorrectly.	Check the wiring to ensure the installed configuration matches wiring diagram on the pump.
The pressure is low.	There is air or gas in the liquid that is running through the pump.	Bleed the air out of the system using an automatic bleeder or manually open a bleeder line at the highest point.
	The impeller diameter is too small.	Check the application requirements; a larger pump may be required.
	The system head is lower than expected.	Check the application requirements; a smaller pump may be required.
	The motor is rotating incorrectly.	Check the wiring to ensure the installed configuration matches the wiring diagram on the pump.
The pump is no longer primed.	There is a leak in the suction piping.	Check the pipe connections and tighten the seals.
The pump is using an excessive amount of power.	The voltage is too low.	Check the generator power output to ensure it is maintaining the proper voltage.
	The specific gravity or viscosity is too high.	Check the fluid mixture concentrations.
The pump is vibrating or making a loud noise.	The pump is cavitating from improper suction or feed.	Ensure the proper inlet pressure is maintained. Check the inlet strainer and the pump lines, and remove debris.
	The pump is not mounted securely.	Use vibration isolators between the pump mount and the mounting surface.

## 9 Disposal



Place the packaging material in the appropriate recycling waste bins, whenever possible. Consult a local recycling center or specialist dealer for details about how to dispose of the product in accordance with all applicable national and local regulations.

## 10 Warranty Information

LIMITED WARRANTY AVAILABLE AT [WWW.DOMETIC.COM/WARRANTY](http://WWW.DOMETIC.COM/WARRANTY).

IF YOU HAVE QUESTIONS, OR TO OBTAIN A COPY OF THE LIMITED WARRANTY FREE OF CHARGE, CONTACT:

DOMETIC CORPORATION  
 MARINE CUSTOMER SUPPORT CENTER  
 2000 NORTH ANDREWS AVENUE  
 POMPANO BEACH, FLORIDA, USA 33069  
 1-800-542-2477









**dometic.com**

---

**YOUR LOCAL  
DEALER**

**[dometic.com/dealer](https://dometic.com/dealer)**

**YOUR LOCAL  
SUPPORT**

**[dometic.com/contact](https://dometic.com/contact)**

**YOUR LOCAL  
SALES OFFICE**

**[dometic.com/sales-offices](https://dometic.com/sales-offices)**

---