

Model: 7.5EKD-Low CO 60 Hz
6EFKD-Low CO 50 Hz

KOHLER POWER SYSTEMS

Gasoline

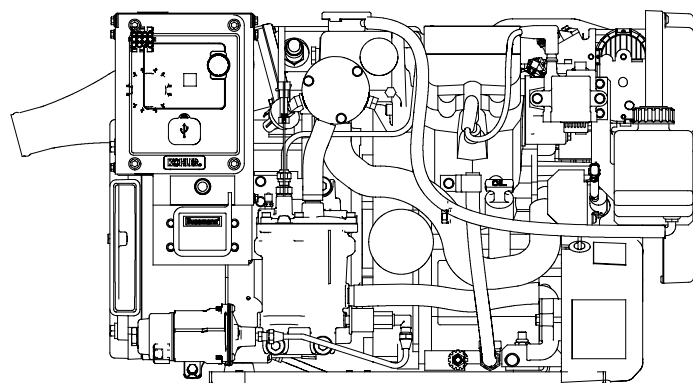

Marine Generator Set

Engine Features

- Gasoline fueled
- Two cylinder
- Four cycle
- Integral heat exchanger
- Lifting eye
- Fuel cooler/pump assembly
- Fuel filter
- Closed cooling system
- CARB/EPA emission compliant
- Sequential-port throttle-body fuel injected
- Ultra low CO emissions

Generator Features

- Remote start 12-pin connector
- Class H insulation
- 60/50 Hz capability
- Voltage regulation of $\pm 1.5\%$
- RFI suppression
- Voltage adjustability
- Captive vibration isolation mounting system

Advanced Digital Control II Features

- Designed for today's most sophisticated electronics
- Easy to read 12 x 2 LCD alpha-numeric display
- Potted boards/sealed connectors for maximum corrosion protection
- J-1939, SmartCraft™, NMEA 2000 selectable CANbus outputs
- Remote monitoring of fault conditions
- Pushbutton dial for configuration and adjustment
- Programmed crank cycle
- CO sensor module

Optional Accessories

- Remote digital gauge (2 or 3 inch)
- Ship-to-shore transfer switch
- Seawater strainer
- Siphon break
- Sound shield

Generator Weights and Dimensions

	Without Sound Shield	With Sound Shield
Weight, kg (lbs.)		
Wet		
7.5EKD	120 (265)	132 (290)
6EFKD	120 (265)	132 (290)
Dry		
7.5EKD	118 (260)	129 (285)
6EFKD	118 (260)	129 (285)
Length, mm (in.)	691 (27.20)	773 (30.43)
Width, mm (in.)	466 (18.35)	500 (19.69)
Height, mm (in.)	445 (17.51)	467 (18.39)

See the drawings on the last page for the detailed dimensions.

Generator Ratings

Model Series	Voltage	Hz	25°C (77°F) Amps	25°C (77°F) kW/kVA
7.5EKD	120	60	62.5	7.5/7.5
	120/240	60	31.3	7.5/7.5
	115/230	50	26.1	6/6
6EFKD	230	50	26.1	6/6
	240	50	25.0	6/6

RATINGS: Marine continuous ratings per ISO 3046, ISO 8528-1, and Kohler ISO rating guideline 2.14. Obtain technical information bulletin (TIB-101) on ratings guidelines for complete ratings definitions.

Availability is subject to change without notice. Kohler Co. reserves the right to change the design or specifications without notice and without any obligation or liability whatsoever. Contact your local Kohler generator distributor for availability.

SmartCraft™ is a trademark of Mercury Marine, a division of Brunswick Corporation.

Application Data

Engine

Engine Specifications	60 Hz	50 Hz
Manufacturer	Kohler	
Model	LH690	
Type	4 Cycle	
Cylinders, number	2	
Displacement, L (CID)	0.674 (41.1)	
Bore and stroke, mm (in.)	80 (3.15) x 67 (2.64)	
Compression ratio	8.5:1	
Rated rpm	3600	3000
Max. power at rated rpm, HP	18.9	15.8
Cylinder block material	Aluminum	
Cylinder head material	Aluminum	
Crankshaft material	Hardened steel	
Piston rings	2 compression/1 oil control	
Crankshaft bearings, type	Insert	
Intake valve material	SAE HNV3 (SIL 1)	
Exhaust valve material	SAE EV8 (21-4N), SAE HNV3 (SIL 1), SAE VF2 (Stellite 6)	
Connecting rod material	Aluminum	
Piston material	Aluminum	
Governor, type	Electronic	

Engine Electrical

Engine Electrical System	60 Hz	50 Hz
Ignition	Inductive	
Starter motor	Bendix automotive type	
Spark plugs	Resistor-type RFI suppression	
Battery voltage (DC)	12	
Battery charging alternator	25 amp	
Battery recommendation (min.)	250 CCA	

Fuel

Fuel System	60 Hz	50 Hz
Type	Sequential-port, throttle body fuel injected	
Low pressure fuel pump	12 psi, electric	
Fuel system, max. lift, m (ft.)	0.9 (3.0)	
High pressure fuel pump, max. lift, m (ft.)	43 psi water cooled electric	

Fuel Consumption	60 Hz	50 Hz
Gasoline, Lph (gph) at % load		
100%	4.24 (1.12)	3.52 (0.93)
75%	3.60 (0.95)	2.99 (0.79)
50%	3.26 (0.86)	2.73 (0.72)
25%	2.73 (0.72)	2.27 (0.60)

Lubrication

Lubricating System	60 Hz	50 Hz
Type	Pressure	
Oil capacity with filter, L (qts.)	1.9 (2.0)	

Cooling

Cooling System	60 Hz	50 Hz
L (qts.)	3 (3.2)	
Heat exchanger type	1.5 in. dia. x 1 pass cupronickel	
Seawater pump type	Belt-driven, 6-blade impeller	
Heat rejected to cooling water at rated kW, wet exhaust Btu/min.	811	676
Engine water pump flow, Lpm (gpm)	37.9 (10.0)	31.5 (8.3)
Seawater pump flow, Lpm (gpm)	22.7 (6)	18.9 (5)

Operation Requirements

Air Requirements (Engine)	60 Hz	50 Hz
Engine combustion air requirements, m ³ /min. (cfm)	1.21 (42.8)	1.01 (35.7)
Generator cooling requirements, m ³ /min. (cfm)	3.4 (120)	2.8 (100)
Exhaust gas flow rate, m ³ /min. (cfm)	3.7 (130)	2.9 (102)
Exhaust gas temperature, °C (°F)	649 (1200)	593 (1100)
Maximum allowable exhaust back pressure, mm Hg (in. Hg)	76.2 (3)	76.2 (3)

Engine Features

- Meets Coast Guard safety standards for electrical systems and gasoline fuel systems (33CFR183)
- One-side serviceability of fuel filter, cooling system, and lubrication system
- Sequential-port, throttle-body electronic fuel injection
- High water temperature, high exhaust temperature, low oil pressure, and loss of seawater cutouts
- Injection-molded, "tuned" air intake
- Disposable oil and fuel filters
- Integral heat exchanger/exhaust manifold
- Oil drain valve
- Full-pressure lube
- Fuel cooler/pump assembly
- "Smart" ignition coils
- Integral 12-volt battery charger
- Unit-mounted overflow bottle
- Cool catalyst

Generator Features

- Brushed, rotating field design permits power to be obtained from stationary leads.
- Rotor and stator are vacuum impregnated and coated with high-bond epoxy varnish. Varnish helps prevent corrosion in high-humidity areas.
- Rotors are dynamically balanced to minimize vibration.
- Copper windings ensure minimal heat buildup. Insulation meets NEMA standards for class H insulation.
- Directly connected to the engine, the generator has sealed precision ball bearings with a precision-machined steel sleeve in the end bracket (or end bearing tolerance ring) to prevent shaft misalignment and extend bearing life.
- Circuit breakers protect the generator from extreme overload.
- Mounted on a drip-proof tray.
- Equipped with a four-lead reconnectable stator.

Application Data

Advanced Digital Control II Features



Controller Features:

- Integrated genset control, spark/fuel control, & voltage regulation
- Selectable Smartcraft™ V1.0, NMEA 2000, & SAEJ-1939 outputs
- Hybrid voltage regulation
- USB interface
 - Ease of uploading and downloading software
 - Historical and diagnostic information
 - Real time diagnostics
 - Front-face accessible
- Onboard CO sensor
- Metering capabilities
- NXP microprocessor with 512 KB Flash and 60 KB RAM
- 179 x 126 x 47 mm (7.1 x 5.0 x 1.9 in.) dimension

Display Type/Features:

- 12 character x 2 line LCD display
- Temperature range (-20 to 70° C)
- Alternative 4 to 6 character alphanumeric LED display
- Displays:
 - Runtime hours
 - Crank cycle status
 - Warnings
 - Faults
 - Diagnostics
 - Setup parameters
 - Software version
- Maintenance minder (customer programmable)
- 2-button keypad: Single power momentary and Start/Stop
- Standard non-membrane switch overlay
- 12 mm rotary encoder knob with pushbutton features:
 - Voltage
 - Gain
 - V/Hz adjustment
- Controller configuration
- Tri-color LED indicator displays system ready, warning, and fault status

SmartCraft™ is a trademark of Mercury Marine, a division of Brunswick Corporation.

Accessories

Sound Shield

Provides for highly effective silencing, ease of access for engine/generator servicing, low maintenance, excellent durability, and safety.

Siphon Break

Mandatory kit for generators installed below the waterline. Prevents the siphoning of flotation water into the engine.

Ship-to-Shore Switch

The Kohler ship-to-shore transfer switch allows immediate switching to the Kohler® generator set power or shore power, protecting the electrical system from the possibility of simultaneous connection to both power sources.

Remote Digital Gauge

Allows starting/stopping from a location remote from the generator set. Standard 76.2 mm (3 in.) dia. hole required for mounting.

Oil Pressure Sender Kit

Provides the sender necessary to display oil pressure on the digital gauge.

Remote Start Panel

Allows starting/stopping from a location remote from the generator set. Supplied with a 101 mm (4 in.) connection harness. The overall mounting dimensions are 128 mm (5.04 in.) by 70 mm (2.76 in.) with a minimum mounting depth of 57 mm (2 1/4 in.).

Remote Connection/Extension Harness

Provides wiring between the remote digital gauge and the ADC connector. Extension limited to a total of four kits and 23 m (75 ft.). Available in 4.6 m (15 ft.) and 7.6 m (25 ft.) lengths.

12-Inch Remote Wiring Harness

Equipped with a 12-pin connector on one end that connects to the standard customer interface connector. Equipped on the other end with leads for connection to customer-supplied wiring.

Line Circuit Breakers

Protects the generator from extreme overload.

Sea Spares™ Maintenance Kit

Kohler's Sea Spares Kit consists of a durable white utility box filled with necessary marine parts.

