

# PJR and PJR-A: Paragon Junior Water Pressure Systems Installation, Operation, and Maintenance

**INSTALLATION:** The motor and circuitry are not waterproof. Install the pump in a dry, well ventilated location not more than 6-feet above the water supply. If the pump will have a flooded inlet the pump may be oriented in any position; if the pump must self-prime, orientation must be upright.

Mount the pump to a sturdy platform using the three (3) mount feet included. Operation is most quiet when mounted to a solid surface.

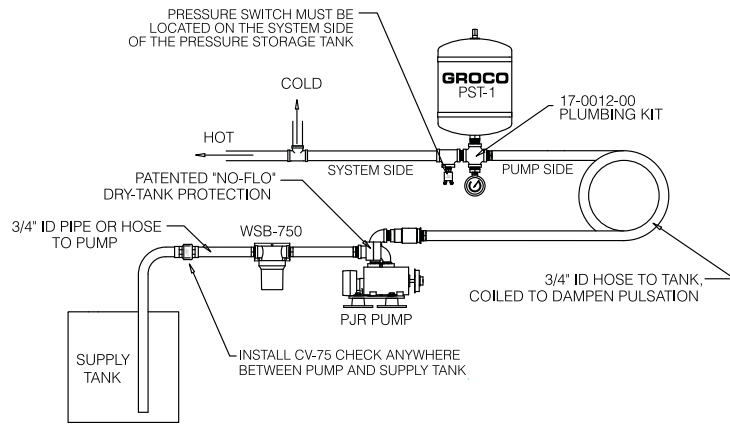

**PLUMBING:** Fasten 17-0012-00 plumbing kit onto the PST (pressure storage tank) with the pressure switch on the system-side of the PST and the hose barb on the pump-side of the PST as shown above. To aid in initial priming, pour water into the pump inlet before connecting hoses to the pump. Plumbing between the pump and the PST must be 3/4" ID heavily reinforced hose, and must be free of valves, filters, or any other device. Plumbing after the PST may be reduced.

Install CV-75 check valve (supplied) anywhere between the supply tank and NOFLO™.

Plumb between the pump and the supply tank with heavily reinforced 3/4" ID hose, and install WSB-750 in the inlet line where it is accessible for service and inspection.

**PRESSURE STORAGE TANK:** PJR requires the use of a Pressure Storage Tank. Use only GROCO® PST-1.

**IMPORTANT:** Before applying power to PJR, the air charge in the PST must be checked and adjusted to 18-20 PSIG. There is an air valve on the tank at the opposite end from the plumbing connection. Remove the protective cap and check and set air pressure with no water pressure present; use a standard tire gauge to check the pressure. Excess pressure can be released by depressing the center of the valve. Use a hand pump such a bicycle pump to add air if necessary.

**WATER FILTERS AND PURIFIERS:** We do not recommend the use of filters as they will seriously restrict the flow and pressure you desire. If you choose to utilize such a filter, it must be installed after the PST. DO NOT install a filter between the supply tank and the pump.

**PRESSURE SWITCH CONNECTION:** A 10-foot wiring harness is provided to make the connection between the pressure switch and the terminal block on the pump base.

**ELECTRICAL:** Do not connect the pump to the boat's bonding system.

Proper wire size is essential. Refer to the wire size selection information included with this product. Connect positive power to the terminal block location marked (+); Connect ground (-) to the terminal block location marked (-). Protect the PJR with a dedicated circuit breaker.

Voltage	Breaker
PJR 12V	30-A
PJR-24V	20-A

START-UP: In preparation for start-up, check all plumbing and electrical connections. Open all faucets and shower heads half-way. Apply power at

the circuit breaker; the pump will run and should self-prime. If the pump does not prime within 30-seconds the dry-tank protection system will turn the pump off. Interrupt power at the breaker panel to reset the pump control. As water flows smoothly from each shower head and faucet, shut it off. When all outlets have been shut off the pump will pressurize the system and shut off. Note that it will take several minutes to fill the PST and the water heater.

**DRY TANK SHUT-DOWN:** These are the dry-tank conditions under which your Paragon Pump will turn off.

- \* NOFLO™ has sensed the absence of water at the pump inlet for 30-seconds
- \* The pump has run continuously for 10-minutes

Paragon Pumps are equipped with a patented dry tank protection system called NOFLO™, which senses the presence of water at the pump inlet. Some purified water such as reverse-osmosis water or reclaimed water may not be sensed by NOFLO™. If this happens the pump may turn off even though water is present.

A jumper wire is installed across the NOFLO™ terminals. The jumper disables NOFLO™ and permits the pump to operate with purified waters. Dry running protection is still provided by a built-in 10-minute timer.

To enable NOFLO™ remove the jumper wire. During normal operation NOFLO™ will sense the absence of water and turn the pump off after 30-seconds of continuous dry running. If your Paragon pump ever shuts off when you know that water is present and the pump has not exceeded 10-minutes of continuous running, reconnect the jumper wire to disable NOFLO™.

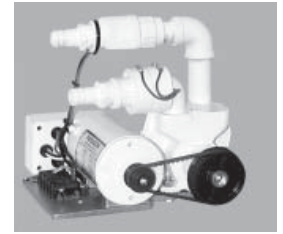

Interrupt power at the breaker panel to reset the pump control.

**Winterization:** Freezing will damage your pump and the connected plumbing. To winterize first allow PJR to pump the supply tank(s) dry. Shut off power when the faucets begin to pass air. Disconnect inlet and outlet hoses to drain the connecting plumbing and remove the WSB-750 bowl. Pour an ounce or two of potable alcohol (your favorite scotch will do fine) into the pump. Reconnect the hoses to prevent evaporation. DO NOT use automotive antifreeze to winterize as it may be poisonous.

**Maintenance:** Check the WSB-750 inlet strainer at least monthly. Check the air charge in the PST at least monthly. This is done with no system water pressure present. With a tire gauge check the air charge. It should be the same as the cut-on pressure of the pump. Add or remove air as needed before applying power to the pump and pressurizing the system with water.

DO NOT lubricate any internal part of the pump.

**SERVICE NOTES:**

- \* Pumps made between S/N 030101-01 and 030615-99 utilized a transducer (identified by stainless steel body and plug-in cable) for on/off pump control. Pumps with transducer may be returned to GROCO for no-charge refit of IPS-38 switch and ETM-D Control.
- \* Adjustable pressure switch #69-A may be substituted for IPS-38, but **must not be used aboard gasoline-powered boats.**

PARAGON JUNIOR CONTROL SUMMARY			
CONTROL	ON-OFF OPERATION	DRY-TANK PROTECTION	COMMENT
ETM	Pressure Switch	Timer	Standard Before S/N 020701 Will Not Work w/NOFLO <sup>1</sup>
ETM-D	Pressure Switch	NOFLO™ & Timer	Standard Between S/N 020201 - 020930 and after 030701-01
ETM-B	Transducer	NOFLO™ & Timer	Between 030115-01 and 030615-99 (no longer available)

# PJR and PJR-A: Paragon Junior Water Pressure Systems

## Installation, Operation, and Maintenance



Item	Part Number	Description	Qty	Item	Part Number	Description	Qty
1-14	P-9000	Pump Assembly	1	8	P-9007	Impeller Guide	1
1,10	P-9001/9002 Set	Pump Castings set	1	9	1420X34HS	Bolt	2
2	P-9009 Set	Carbon Bearings (2)	1				
• 3	P-9014 Set	Impellers (2)	1	12	P-9020	End Cap	1
4,14	P-9003/4 Assy	Shaft and Eccentrics Set	1	13	1032x316SS	Set Screw	2
5	P-9006	Separator	1	17	P-8004-A	Base	1
• NS	P-9006-A	Separator Washer Set (2)	1	18	(Voltage)-F	Motor	1
•• 6	P-9005	Seals (2) (before 1/85)	1	20	1032X12HS	Bolt	2
•• 2-010		O-Ring (2) (after 1/85)	1				
•• 7	2-041	O-Ring (before 1/86)	1	21	P-9022-A	Mount Foot Set (3)	1
•• 2-042		O-Ring (after 1/86)	1	22	Control*	Electronic Dry Tank Module	1
••• 11	P-9015	Seal	1	23	1428X12HS	Bolt	4
• 15	P-8002	Pulley for pump	1	NS	P-9021-A	Check valve	1
• 19	P-8001	Pulley for motor	1	NS	P-8005-A	Pressure Gauge	1
• 25	P-8003	Belt	1		P-8005-B	Pressure Gauge (oil filled)	
• NS	WSA-751	WSA or WSB Filter Basket	1	NS	NOFLO-7500	Dry Tank Sensor (After SN030101-01)	1
• NS	WSA-752	WSA or WSB Strainer Gasket	1				
•	<b>PJR Regular</b>	<b>Service Kit</b>					
•	<b>PJR Master</b>	<b>Service Kit</b>				<b>*Refer To Control Summary Chart</b>	

