

**MARINE** PRODUCT DATA SHEET

DEM: 253-120-00

AFTERMARKET: 253-120-01



SHURflo's family of Raw Water Strainers are built to keep your bait tank, livewell and washdown pumps protected from harmful debris. The Raw Water Strainer features a clear twist off bowl and removable stainless steel screen, which allows for easy inspection and cleaning. An integral o-ring creates a tight seal, eliminating possible leaks. Keep your pumps and components lasting longer by protecting them with the SHURflo Raw Water Strainer.

**TYPICAL APPLICATIONS**

Raw Water Strainer. Vacuum side application only. For other applications contact SHURflo.

**MATERIAL**

Top Housing: Nylon  
 Bowl: Polymide  
 Gasket: Buna  
 Screen: 50 Mesh T304 Stainless Steel

**SPECIFICATIONS**

Inlet Port: 1/2" NPT-F  
 Outlet Port: 1/2" NPT-F  
 Max Temp: 120°F [48°C]  
 Max Pressure: Vacuum Side Only

**RELATED DOCUMENTS**

Catalog: MS-030-140 / MS-03083  
 Warranty: 1 Year Limited SB-1041 / SB-1050

Exploded View—Parts Kits Not Available

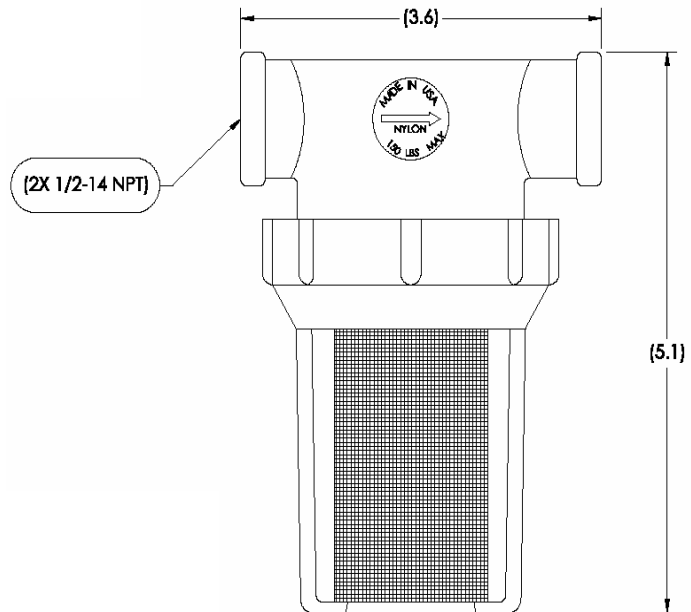

\*ISO Registered Facility

SHURflo reserves the right to update specifications, prices, or make substitutions.

SHURflo, LLC\*  
 5900A Katella Ave.  
 Cypress, Ca. 90630  
 Phone: 800 854 3218  
 Fax: 562 795 7554  
 Shipping: 5900C Katella Ave.  
 Cypress, Ca. 90630

SHURflo East  
 52748 Park Six Court  
 Elkhart, IN 46514-5427  
 Phone: 800 854 3218  
 Fax: 574 264 2169  
 Http://www.shurflo.com  
 ©2001

SHURflo Ltd.\*  
 Unit 5, Sterling Park  
 Gatwick Road, Crawley  
 West Sussex, RH10 9QT  
 United Kingdom  
 Phone: 0044 (0) 1293 424 000  
 Fax: 0044 (0) 1293 421 880

